



The Specifier's Catalogue

VALVES



Flow Control Valves



12/14



Catalogue also available on digital media

Visit our website for a full online search facility

[www.bisvalves.co.uk](http://www.bisvalves.co.uk)

**BIS VALVES LTD**

Unit 17 - 23, Kingfisher Park, Collingwood Road, West Moors, Wimborne, Dorset, BH21 6US, UK

T. +44(0) 1202 896322

F. +44(0) 1202 896718

E. [salesadmin@bisvalves.co.uk](mailto:salesadmin@bisvalves.co.uk)

Flow Control  
**VALVES**  
The Specifier's Catalogue



# Welcome to BiS Valves

BiS is an internationally recognised company with over 40 years experience in the design and manufacture of a wide range of small bore stainless steel pressure and flow control valves for high pressure liquid and gas.

Operating in a variety of sectors, we are a leading supplier to the Offshore Oil and Gas industry for topside, subsea and downhole applications where quality, reliability and safety are critical.

With an extensive range of standard products and a bespoke design service we aim to provide the right solutions for your applications.

## Markets

BiS has a strong profile and presence in the international offshore oil and gas market in both topside and subsea applications. Products are designed mainly for the low flow, high pressure control valve market where demands for higher pressures and total reliability in the most extreme environments constantly push design boundaries. Working with materials from stainless steel to the more exotic, such as Inconel or titanium, we pride ourselves on finding the right solution, whatever the application.

As a supplier to the oil and gas topside market, our products are widely specified for use on a range of applications including hydraulic power units, work over control systems and chemical injection systems. As a solution provider, BiS also designs, manufactures and supplies complete integrated manifolds to meet our customers' specific requirements.

BiS Valves also has extensive experience providing products for subsea and downhole applications such as wellhead control, emergency shut-down and remotely operated vehicles. Our strong design team backed up with the latest test equipment is well suited to development of the bespoke products often required for subsea applications.

Our standard, cartridge and manifold mounted flow and pressure control products are also suited to and specified in a wide range of industries, including water hydraulics, fuel distribution, metal manufacturing, industrial gas control and process control.

## Technology

Alongside our large range of standard products, BiS has the capability to design and manufacture the special product that is the perfect fit for your system.

Using our experience of fluids, materials and seals, our team of hydraulics engineers use computer aided design tools to develop the right solutions. Designs can be qualified for use via in-house test facilities which can include flow, pressure, environmental and hyperbaric testing, and special testing through external facilities when required.

## Customer Care

In a competitive market place we recognise the importance of customer care, whether your requirement is for a single valve from our standard range, large quantities of multiple products for a specific project, or for a bespoke design. Our team constantly strive to provide customers with a prompt, efficient service, competitive lead times, on-time deliveries, and products designed, manufactured, assembled and tested in accordance with strict quality control procedures.

We enjoy a reputation for short lead times and our flexible manufacturing methods give us the capability to respond to your most urgent requirements.



## Using This Catalogue

The data sheets in this catalogue are intended to provide the information necessary to specify product model numbers for the majority of applications. However, at BiS Valves we understand that every application is different and our team are always available to assist with product selection. The data sheets should always be read in conjunction with the Application Notes contained in this catalogue.

## Cannot see the product you need?

Our current standard range features a large number of carefully selected products but does not represent all the products available from BiS Valves. If there is an item that is not shown in this catalogue, please e-mail or call our Sales team and we will do our utmost to help you.

## Contact Us

Telephone	<b>+44 (0)1202 896322</b> We are here to provide you with advice and support. Simply call us on +44 (0)1202 896322 and be directed to our Sales department. Orders can be placed from 8:00am to 5:00pm Monday to Thursday and 8:00am to 4:00pm Fridays.
Fax	<b>+44 (0)1202 896718</b> Send your purchase order or quote request by fax 24 hours a day, 7 days a week
E-mail	<b>salesadmin@bisvalves.co.uk</b> To place an order, request a quotation or to ask a question, why not e-mail?
Online	<b>www.bisvalves.co.uk</b> View the latest product range on our website, request a quotation or ask a question
Post	<b>BiS Valves Ltd.</b> Units 17-23 Kingfisher Park, Collingwood Road, West Moors, Wimborne, Dorset, BH21 6US, UK
Global Partners	Based in strategic locations around the world with local expertise and stocks of the most popular products, our Global Partners are ready to take your call. <i>Visit our website to find your local partner.</i>

## Important Notes

1. Full terms and conditions of sale are included at the back of the catalogue.
2. Every effort has been made to ensure that the contents of this catalogue are accurate. No liability will be accepted by BiS Valves for any errors or omissions.
3. BiS Valves operate a policy of continuous improvement and reserves the right to modify any part of the design of its products without prior notice.
4. For any piece of equipment where specifications or dimensions are considered critical, it is recommended to contact our Technical Department for the latest details.
5. The products should be installed and used by qualified personnel familiar with the risks associated with pressure equipment and in compliance with the local regulations in force, and any installation, operation and maintenance instructions supplied with the product.
6. BiS Valves will offer all possible assistance to ensure correct product selection, but it is the ultimate responsibility of the customer to ensure that the final product selection is suitable for the intended application.



SOLENOID  
FLOW CONTROL  
3 PORT DIRECTIONAL CONTROL  
4 PORT DIRECTIONAL CONTROL  
CHECK AND SHUTTLE  
PILOT OPERATED CHECK  
RELIEF  
EXCESS FLOW  
FILTERS  
PRESSURE SENSING  
PUMPS  
ACTUATORS  
TECHNICAL DATA

### Introduction

BiS Valves offer an extensive range of flow control valve products, in cartridge, manifold mounted and ported installation formats.

### Stop Valves

Stop valves, often known as shut-off or isolation valves, are manually operated valves used to block or open flow lines. Nearly all hydraulic and pneumatic circuits contain stop valves as a critical part of the functionality. Typical applications include isolation of hydraulic circuits or components, providing a method of releasing pressure, and the locking in of pressure during pressure tests.

Typical Uses

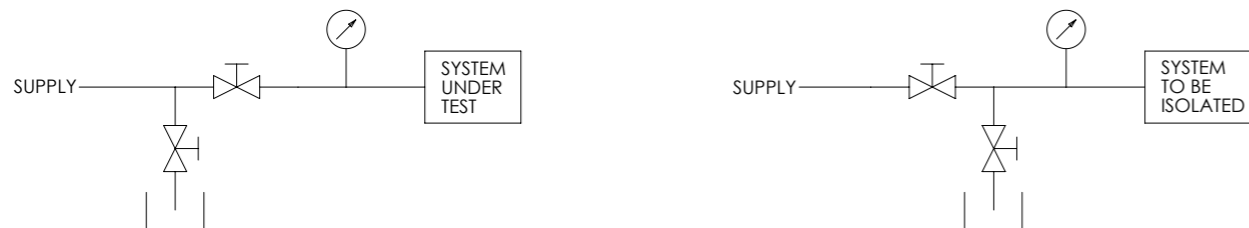

When pressure testing it is desirable to minimise the number of leakage points exposed to the system under test. In the configuration shown supply pressure can be removed leaving only trapped pressure in the system being tested.

When it is necessary to isolate and remove pressure from part of a system, a block-and-bleed configuration can be used.

### Metering Valves

Metering valves, often known as needle valves, are used to regulate flow and are most often used to control the speed of an actuator. They can be used in either "meter-in" or "meter-out" speed control systems and many are available with integrated check valves such that the flow control is provided in only one direction. Metering valves are not designed to provide a shut-off function and where this is required it is necessary to fit a separate Stop valve.

Typical Uses

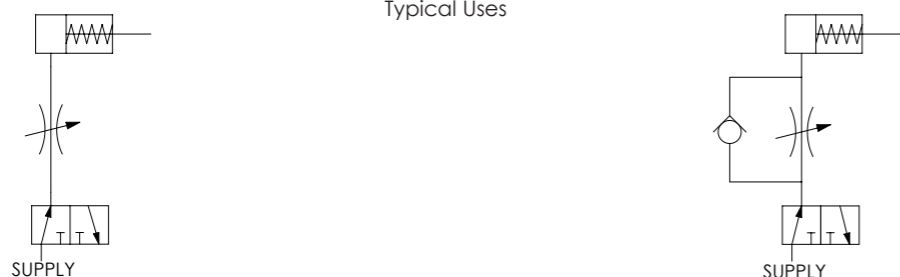

In the configuration shown the metering valve provides bi-directional speed control of the actuator. The speed when extending is likely to differ from the retract speed as it will be dependent on pressure drop across the metering valve.

Using a metering valve with integral check, speed control is provided in the extend direction only. Reversing the connections to the metering valve allows speed control to be in the retract direction only.

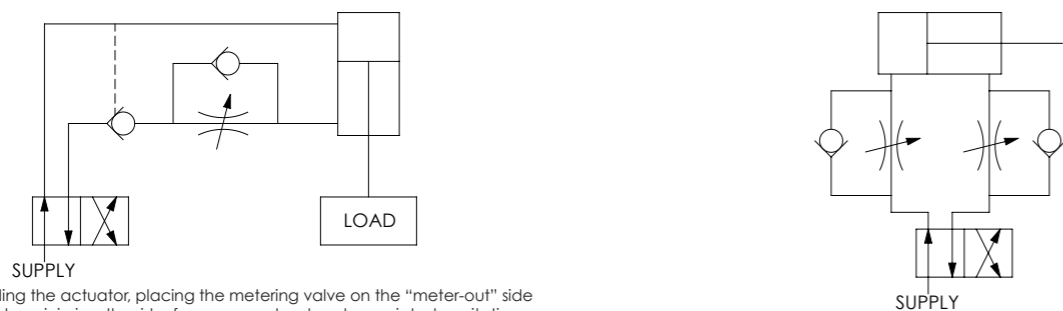

When extending the actuator, placing the metering valve on the "meter-out" side of the actuator minimises the risk of a run-away load and associated cavitation. Adding a pilot operated check valve further reduces risk by ensuring that a positive pressure is always present on the full bore side of the actuator.

Utilising two metering valves with integral check valves provides entirely independent speed control of both the extend and retract functions.

### Pressure Compensated Flow Regulators

Where either the supply pressure or the pressure required to operate an actuator is variable, the use of standard metering valves can lead to a high variation in actuator speed. In these circumstances, a pressure compensated flow regulator can be used, and this will provide an approximately constant flow rate over a wide range of differential pressures. Pressure compensated valves cannot be used to provide a shut-off function and where this is required it is necessary to fit a separate stop valve.

### Selecting the Correct Product

Selection guide for stop valves

	Page	Suitable for liquids	Suitable for gases	1/4" - 3/8" BSP / NPT ports	1/2" - 1" BSP/NPT ports	Medium pressure ports	Cartridge installation	Manifold mount installation	T-bar handle
BNV10FC	5	✓					✓		✓
BNV25	6 - 7	✓		✓			✓	✓	
BNV25-G	8 - 9	✓	✓	✓			✓	✓	
BNV25-TB	10 - 11	✓		✓			✓	✓	✓
BNV50	12	✓			✓				
BNV50-G	13	✓	✓		✓				
BNV44AE	14 - 15	✓				✓			✓
BNV56AE	16 - 17	✓				✓			✓
BNV81AE	18 - 19	✓				✓			✓

**Important** – This is a guide to selecting products that may be suitable. The valve data sheet and application notes must be thoroughly reviewed prior to final selection. Please contact us if the options you require are not shown

Selection guide for metering valves

	Page	Suitable for liquids	Suitable for gases	1/4" - 3/8" BSP / NPT ports	1/2" - 1" BSP/NPT ports	Cartridge installation	Manifold mount installation	Integral check valve	Pressure Compensated
MF25	20 - 21	✓	✓	✓		✓	✓		
FMF25	22	✓	✓	✓					
VFMF25	23	✓	✓	✓					
MF37	24	✓	✓	✓					
MF50	25	✓	✓		✓				
MF75	26	✓	✓		✓				
MF100	27	✓	✓		✓				
CMF25	28	✓	✓	✓				✓	
CMF37	29	✓	✓	✓				✓	
CMF50	30	✓	✓		✓			✓	
CMF75	31	✓	✓		✓			✓	
CMF100	32	✓	✓		✓			✓	
IMC25	33	✓		✓				✓	
IMC37	34	✓		✓				✓	
IMC50	35	✓			✓			✓	
PCFR50	36	✓			✓	✓			✓

**Important** – This is a guide to selecting products that may be suitable. The valve data sheet and application notes must be thoroughly reviewed prior to final selection. Please contact us if the options you require are not shown



### Application Notes

#### Intended Use

The products in this catalogue have many potential applications and are used across a wide variety of industries. They are primarily intended for use in industrial and onshore and offshore topside applications. Products should always be used within the parameters specified on the product data sheet, and should be installed, operated and maintained in accordance with the instructions supplied. BiS Valves will offer all possible assistance to ensure correct product selection, but it is the ultimate responsibility of the customer to ensure that the final product selection is suitable for the intended application.

#### Prohibited Uses

The products in this catalogue are not intended for use in automotive, shipbuilding, aerospace, military or nuclear applications. The products are not designed for contact with foodstuffs. Use with oxygen or with oxygen rich gas mixes is prohibited. Please contact BiS Valves prior to ordering products for use in any of the above applications.

#### Subsea Applications

Suitability for subsea applications should not be assumed unless it is specifically stated on the product data sheet. In many cases BiS Valves have subsea variants of standard catalogue products available, or can design bespoke subsea variants specifically for your application. Please do not hesitate to contact BiS Valves with your requirement.

Where the product data sheet states suitability for short term subsea use, this should be interpreted as meaning that the product is capable of functioning subsea but that corrosion will occur over time. The acceptable length of deployment will depend on the specific subsea environment and the effect of that environment on the exposed materials of construction, which should be evaluated by the customer.

Where the product data sheet states suitability for subsea use, this should be interpreted as meaning that the product is capable of functioning subsea and that the externally exposed materials of construction will withstand longer term subsea use. The acceptable length of deployment will depend on the specific subsea environment and the effect of that environment on the exposed materials of construction, which should be evaluated by the customer. It is recommended that BiS Valves are consulted where deployment is intended to exceed five years without retrieval and refurbishment and for deployment depths greater than 3,000 metres. For all long term deployments, it is recommended that the system is designed such that failure of a single component does not cause failure of critical system functions.

For subsea applications, take care to choose an appropriate subsea suitable piping system. BiS Valves recommend that particular care is taken if selecting BSP ported products for subsea use.

#### Cleanliness

Fluid cleanliness is critical to the reliability of all fluid power products. BiS Valves take every precaution to ensure that products are clean at the time of supply. Component parts are cleaned prior to assembly and testing is carried out with test fluids verified as clean to a maximum of AS4059 class 6B-F.

For maximum service life it is recommended that the products are used with fluid maintained at or below AS4059 class 6B-F. Use with higher levels of contaminant should be expected to result in a reduction in service life. Certain product designs are inherently more robust in systems where fluid cleanliness cannot be guaranteed, and it is recommended to contact BiS Valves prior to ordering products for use in such applications.

There is an increased risk of damage to the product at the time of installation, due to contaminant generated during the assembly of the system and associated pipework. Precautions should be taken to ensure that contaminant is not transferred into the product during flushing procedures and initial system operations.

Where fluid contamination presents a risk of failure to critical valve functions, it is recommended to consider fitting a device protection filter from the BiS Valves F or EF ranges. However, this should not be considered as being a substitute for sound hydraulic cleanliness practise.

#### Product Testing

All products are tested for proof pressure integrity, typically at 1.5 times the working pressure, and are tested to ensure correct functionality as part of our standard manufacturing process. Testing will be carried out using an appropriate test fluid that suits the specific product being tested. The test fluid used will be referenced on the test certificate supplied with the product. In cases where the test fluid used is not compatible with the media in the system into which the product will be installed, the customer may need to flush the product prior to installation. If the product to be supplied must be tested using a specific fluid, please ensure that this is requested prior to quotation and ordering.

#### Leakage

BiS Valves products are typically designed to provide the very low leakage levels expected by the offshore oil and gas industry, other than certain products such as flow control valves that are not intended to fully close. The actual leakage rate achieved will depend on various factors, such as fluid viscosity and pressure differential, but with liquids is expected to be below a level where it is appropriate to measure by collecting a fluid volume or counting drops, hence a pressure decay and trapped volume method of leakage detection is used. If the product to be supplied must be tested to prove a specific leakage rate, please ensure that this is requested prior to quotation and ordering, such that the suitability of the product and the standard test procedure may be assessed.

#### Materials

Each product data sheet gives limited guidance relating to the generic type of operating media with which the product is suitable, and the materials of construction. As part of our quotation and order process, BiS Valves will supply an Application Data Request form and from the data supplied will give all possible assistance to ensure correct product selection. However, since it is not possible for BiS Valves to validate products against every conceivable operating parameter, it is essential that the customer satisfies themselves that the product is suitable for their specific application prior to purchase and use.

Alternative construction materials, including exotics, can often be made available on request.

#### Seals

Each product data sheet contains model code options for various seal materials that are available as preferred options. Many other seal materials and grades are available. Please contact us for a quotation.

Where generic standard materials are specified (eg. Viton®, nitrile, etc), the exact grade of material cannot normally be guaranteed. If you require a specific grade of seal material, please specify when requesting a quotation.

When choosing or specifying a seal material, always ensure that the material is suitable for the application in terms of both temperature and chemical compatibility. Always seek advice from the fluid manufacturer if in doubt with regards to material compatibility. Never specify Ethylene Propylene seals for use with mineral oils or other hydrocarbon based media.

Viton® and Kalrez® are registered trademarks of E.I. du Pont de Nemours and company or its affiliates. BiS Valves use genuine Viton® and Kalrez®.

#### Pressure Equipment Directive 2104/68/EU

The products in this catalogue are classified as Pressure Accessories in terms of the definitions within the Pressure Equipment Directive. Since the products fall below sizes specified within the Directive, the products fall outside categories I to IV, and hence are engineered in accordance with "sound engineering practise" and are not supplied with a CE mark.

#### ATEX Directive 2014/34/EU

The majority of products supplied by BiS Valves can be used in hazardous areas containing potentially explosive atmospheres covered by the ATEX and DSEAR regulations, for zones 1 and 2. As standard, products are not CE marked and should not be used in these environments. However, should use in these areas be required, please ensure that the requirement is specified, along with the zone in which the equipment is to be used, when requesting a quotation or ordering. Following assessment, the products can normally be supplied with a CE mark and declaration of conformity at no extra charge.

#### NACE MR01-75

Many products supplied by BiS Valves can be configured for use in sour H2S containing environments. This often requires some material changes from the standard product. Where compliance with NACE MR01-75 is required, please specify when requesting a quotation.

#### Traceability

Unless otherwise requested, only the main pressure containing component in finished products are traceable back to original material. Should either full or a greater level of traceability be required, please ensure that this is specified when requesting a quotation.

#### Documentation

Standard documentation supplied with BiS Valves products includes a pressure test / conformity certificate, parts list (including available spare parts), assembly drawing, installation, operation and maintenance instructions, and a material certificate for the main pressure containing component, along with any EC conformity declarations appropriate to the product. If further documentation is required, please specify when requesting a quotation. Documentation is delivered as a hard copy with the goods. If electronic documentation is required, please specify when ordering.

#### Maintenance

Due to the wide variety of applications in which BiS Valves products are utilised, it is impossible to set generic service intervals. It is recommended that the end user should assess their application, including factors such as duty cycle, hostility of the environment both inside and outside the product, and the criticality and consequence of failure, and set in place a preventative maintenance schedule accordingly. It is further recommended that performance is monitored and reviewed to refine the balance between reliability and cost.

It is recommended that products are returned for repair and refurbishment by BiS Valves. However, it is acknowledged that this may not always be possible, and Seal Kits and Repair Kits are available for most BiS Valves products. Product maintenance should only be carried out following safe isolation from the system, in clean conditions, by competent personnel, and fully in accordance with the maintenance instructions supplied.

#### Warranty

BiS Valves warrants that for a period of 12 months from the date of first use or for a period of 24 months from date of delivery (whichever expires first) the product shall be free from material defects in design, material and workmanship. Should it be necessary to return a product, please contact the BiS Valves sales team in advance. This is of additional importance if the goods are being returned to the UK from non EU countries, to allow BiS to ensure compliance with the relevant UK customs procedures. Failure to comply can result in a demand for payment of Customs Duties which BiS may have to pass on to the customer.



# BNV10FC

## STOP VALVE

1/8"

UP TO 1,379 BAR  
20,000 PSI



The BNV10FC is a cartridge style stop valve. It provides tight shut-off when closed via a T-bar handle.

Coarse adjustment allows fast operation. The valve may be used with the same functionality in either direction.

- Manual stop or shut-off valve
- Lockable adjustment
- Cartridge style ideal for use in manifolds
- Non-rotating valve stem protects valve seat
- Metal to metal seating with hardened stem for durability
- Suitable for uni-directional or bi-directional shut-off
- Short handle option for pressures up to 862 bar (12,500psi) allows compact system designs
- Stainless steel construction
- Suitable for use with mineral oils, water glycols and plain water
- Compatible with many other media, contact us for advice
- Various seal options available

### Specifications

**BASIC MODEL NUMBER**

**BNV10FC**

**SYMBOL**

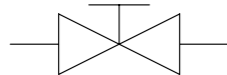

**MAX WORKING PRESSURE**

1,379 bar  
(20,000 psi)

**CV (FLOW CAPACITY)**

Up to 0.20  
See performance graph

**FLUID**

Liquids only  
See materials section

**TEMPERATURE RANGE**

See Product Selector opposite  
and Technical Data section

**NOMINAL SIZE**

1/8"

**WEIGHT**

0.29 kg  
(0.64 lb)

Specifications may change without notice

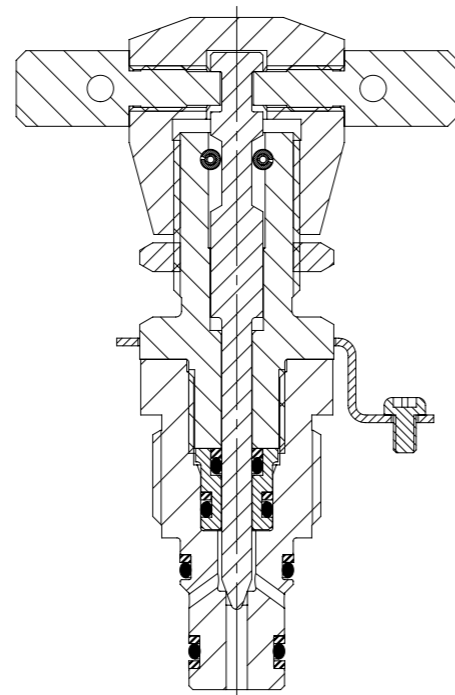

### Materials

Externally Exposed Parts: 316 stainless steel and aluminium bronze.

Internally Wetted Parts: 316 and 17-4 PH stainless steel and acetal.

The standard valve is designed for use with mineral oil, water glycols and plain water, but may be used with a wide variety of media compatible with the materials of construction. Other material options are available, please contact us for advice.

⚠ The standard valve has Viton® seals. Further seal options are available via the Product Selector. Compatibility with the working fluid at the operating temperature must be considered.

### Typical Performance

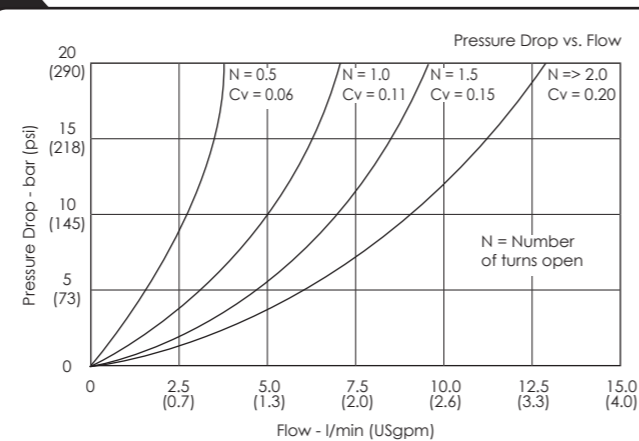

Typical performance based on water

### Installation Diagram

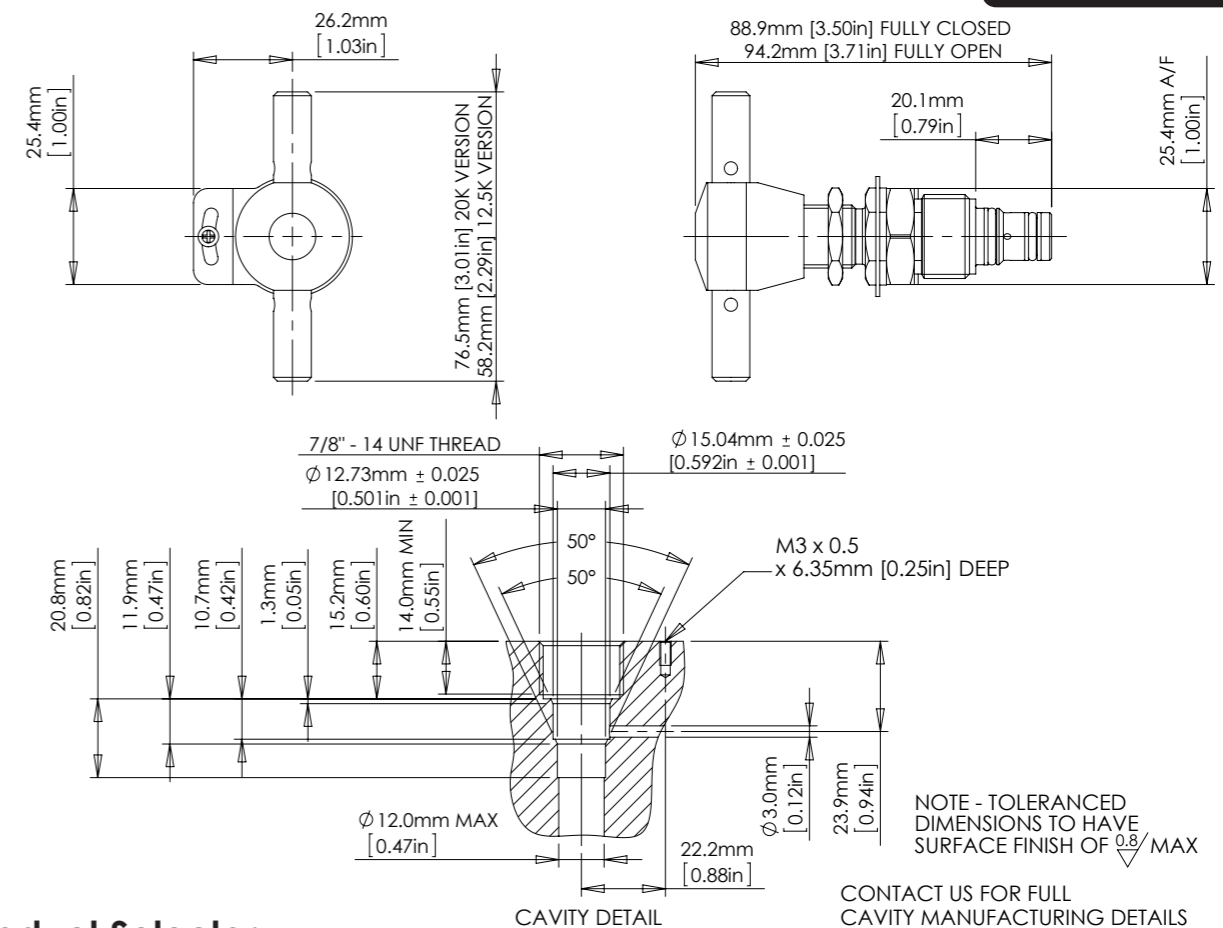

### Product Selector

#### BNV10 FC - NBR - 12.5K

VALVE TYPE	PORTING OPTIONS	SEAL OPTIONS	MAX WORKING PRESSURE
<b>BNV10</b>	FC option must be selected <b>FC</b> Full cartridge Seat in cartridge	Leave blank for Viton® seals -10°C to +120°C <b>NBR</b> Nitrile seals -30°C to +105°C <b>EP</b> EPDM seals -45°C to +120°C <b>KLZ</b> Kalrez® seals -25°C to +120°C <b>HNBR</b> Hydrogenated Nitrile seals -20°C to +120°C Further seal options are available on request ⚠ Exposure to high and low temperature will influence handle temperature. Operator safety must be considered	<b>12.5K</b> 862 bar (12,500 psi) Liquid  <b>20K</b> 1,379 bar (20,000 psi) Liquid

Repair and seal kits are available on request  
For a seal kit add SK at the end of the model code and for a repair kit add RK



Catalogue also available on digital media  
Visit our website for a full online search facility  
[www.bisvalves.co.uk](http://www.bisvalves.co.uk)

**BIS VALVES**  
The Specifier's Catalogue

SOLENOID  
FLOW CONTROL  
3 PORT DIRECTIONAL CONTROL  
4 PORT DIRECTIONAL CONTROL  
CHECK AND SHUTTLE  
PILOT OPERATED CHECK  
RELIEF  
EXCESS FLOW  
FILTERS  
PRESSURE SENSING  
PUMPS  
ACTUATORS  
TECHNICAL DATA

# BNV25

## STOP VALVE

1/4" 3/8"

UP TO 690 BAR  
10,000 PSI

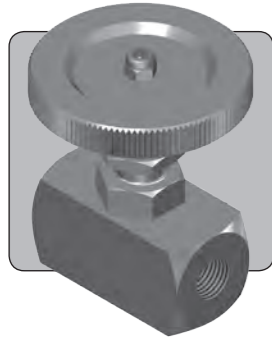

The BNV25 is a 1/4" nominal bore stop valve. It provides tight shut-off when closed via the knurled handwheel.

Coarse adjustment allows fast operation. For uni-directional service, the valve is marked with a preferred direction of flow, but the valve may be used with the same functionality in the opposite direction.

- Manual stop or shut-off valve
- Lockable adjustment
- Panel mount option
- Non-rotating valve stem protects valve seat
- Suitable for uni-directional or bi-directional shut-off
- Stainless steel construction
- Suitable for use with mineral oils, water glycols and plain water
- Compatible with many other media, contact us for advice
- NACE MR01-75 compliant versions available, contact us for advice
- Various porting options available, including manifold mount and cartridge installation options
- Various seal options available

### Specifications

<b>BASIC MODEL NUMBER</b>	<b>BNV25</b>
<b>SYMBOL</b>	
<b>MAX WORKING PRESSURE</b>	690 bar (10,000 psi)
<b>CV (FLOW CAPACITY)</b>	Up to 0.52 See performance graph
<b>FLUID</b>	Liquids only See materials section
<b>TEMPERATURE RANGE</b>	See Product Selector opposite and Technical Data section
<b>PORT SIZE</b>	1/4" or 3/8"
<b>WEIGHT</b>	<p><b>PORTED</b> 0.65 kg (1.43 lb)</p> <p><b>C</b> 0.35 kg (0.77 lb)</p> <p><b>FC</b> 0.50 kg (1.10 lb)</p>

Specifications may change without notice

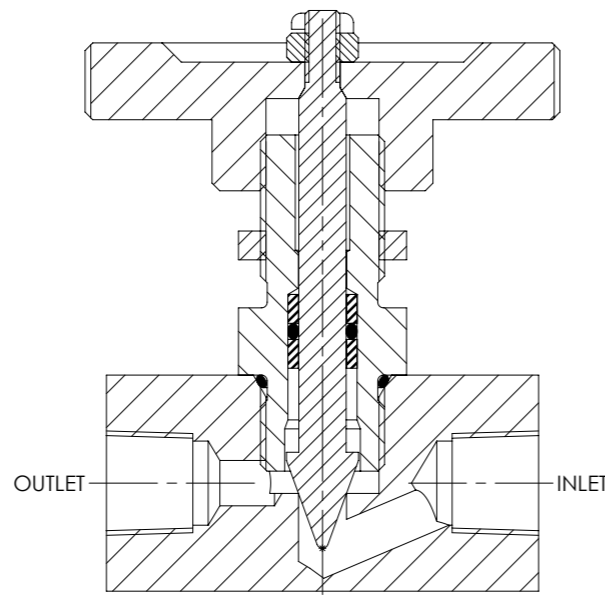

### Materials

Externally Exposed Parts: 316, 17-4 PH and other 300 series stainless steels. Electroless nickel plated bolts for the manifold mount version. Internally Wetted Parts: 316 and 17-4 PH stainless steel, acetal and PTFE.

The standard valve is designed for use with mineral oil, water glycols and plain water, but may be used with a wide variety of media compatible with the materials of construction. Other material options are available, please contact us for advice.

**⚠** The standard valve has Viton® seals. Further seal options are available via the Product Selector. Compatibility with the working fluid at the operating temperature must be considered.

### Typical Performance

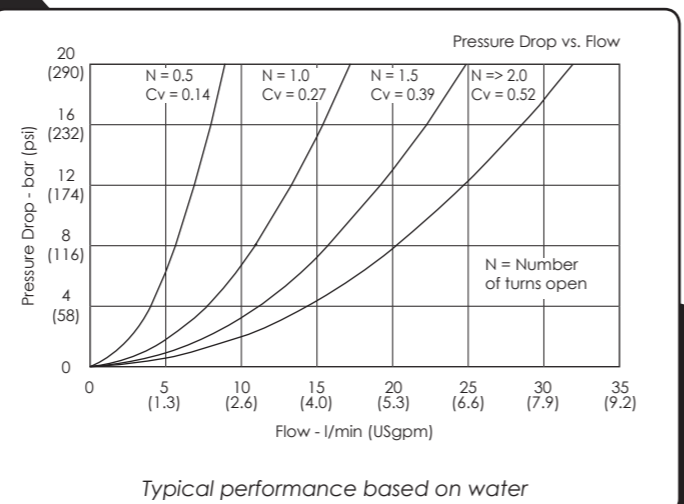

### Installation Diagram

#### STANDARD VALVE

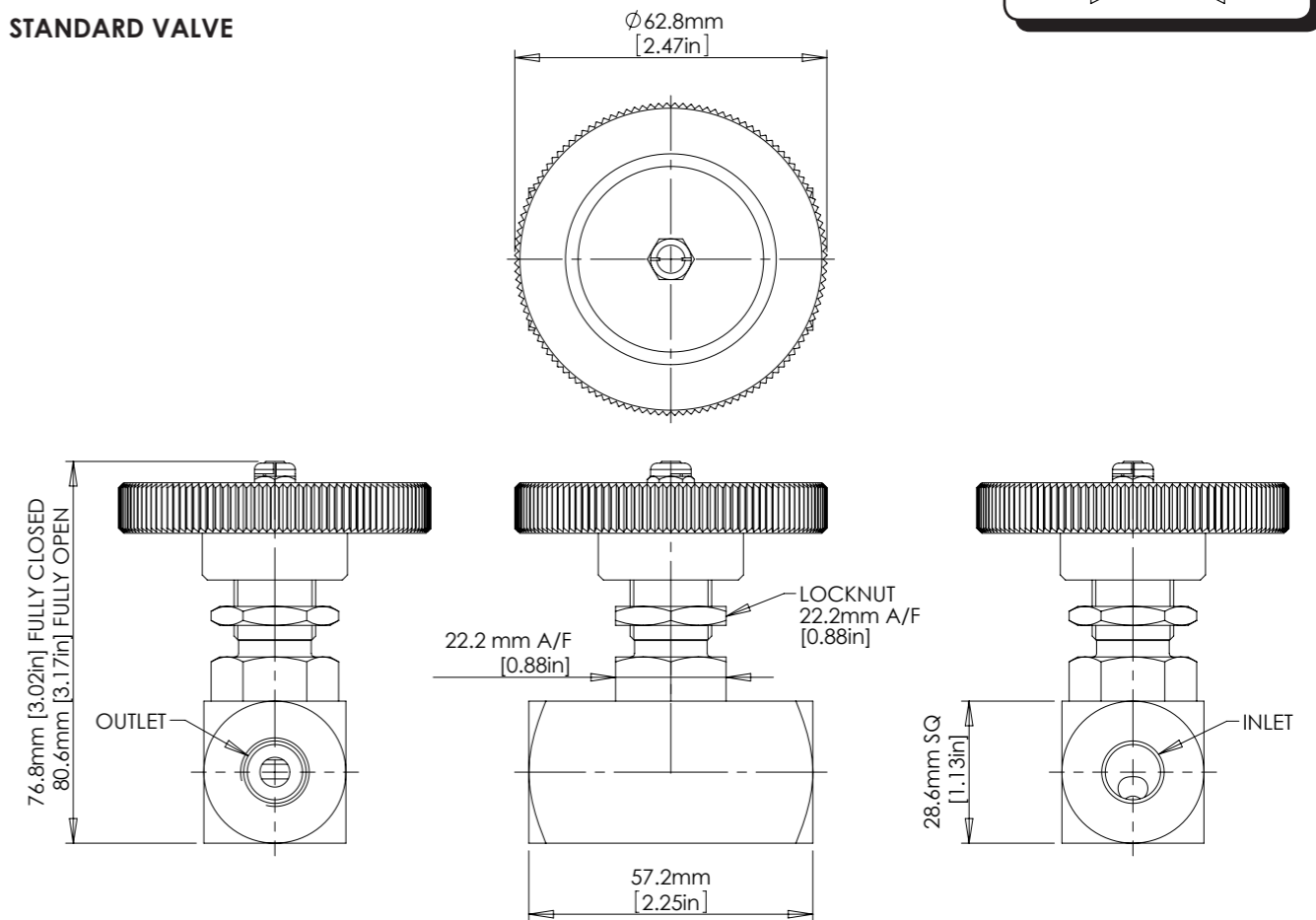

### Product Selector

BNV25 P - PM - NBR - 10K				
VALVE TYPE	PORTING OPTIONS	VALVE OPTIONS	SEAL OPTIONS	MAX WORKING PRESSURE
BNV25	<p><b>P</b> 1/4" BSPP female</p> <p><b>N</b> 1/4" NPT female</p> <p><b>/37P</b> 3/8" BSPP female</p> <p><b>/37N</b> 3/8" NPT female</p> <p><b>M</b> Manifold mount</p> <p><b>C</b> Cartridge style Seat in cavity</p> <p><b>FC</b> Full cartridge Seat in cartridge</p>	<p>Leave blank if not required</p> <p><b>PM</b> Panel mounted Not available for manifold or cartridge versions</p>	<p>Leave blank for Viton® seals -10°C to +120°C</p> <p><b>NBR</b> Nitrile seals -30°C to +105°C</p> <p><b>EP</b> EPDM seals -45°C to +120°C</p> <p><b>KLZ</b> Kalrez® seals -25°C to +120°C</p> <p><b>HNBR</b> Hydrogenated Nitrile seals -20°C to +120°C</p> <p>Further seal options are available on request</p> <p><b>⚠</b> Exposure to high and low fluid temperatures will influence handle temperature. Operator safety must be considered</p>	<p><b>10K</b> 690 bar (10,000 psi) Liquid</p>
<p>Repair and seal kits are available on request</p> <p>For a seal kit add SK at the end of the model code and for a repair kit add RK</p>				



Catalogue also available on digital media  
Visit our website for a full online search facility  
[www.bisvalves.co.uk](http://www.bisvalves.co.uk)

SOLENOID  
FLOW CONTROL  
3 PORT DIRECTIONAL CONTROL  
4 PORT DIRECTIONAL CONTROL  
CHECK AND SHUTTLE  
PILOT OPERATED CHECK  
RELIEF  
EXCESS FLOW  
FILTERS  
PRESSURE SENSING  
PUMPS  
ACTUATORS  
TECHNICAL DATA

# BNV25

## STOP VALVE

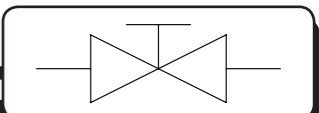

### Cartridge Valve

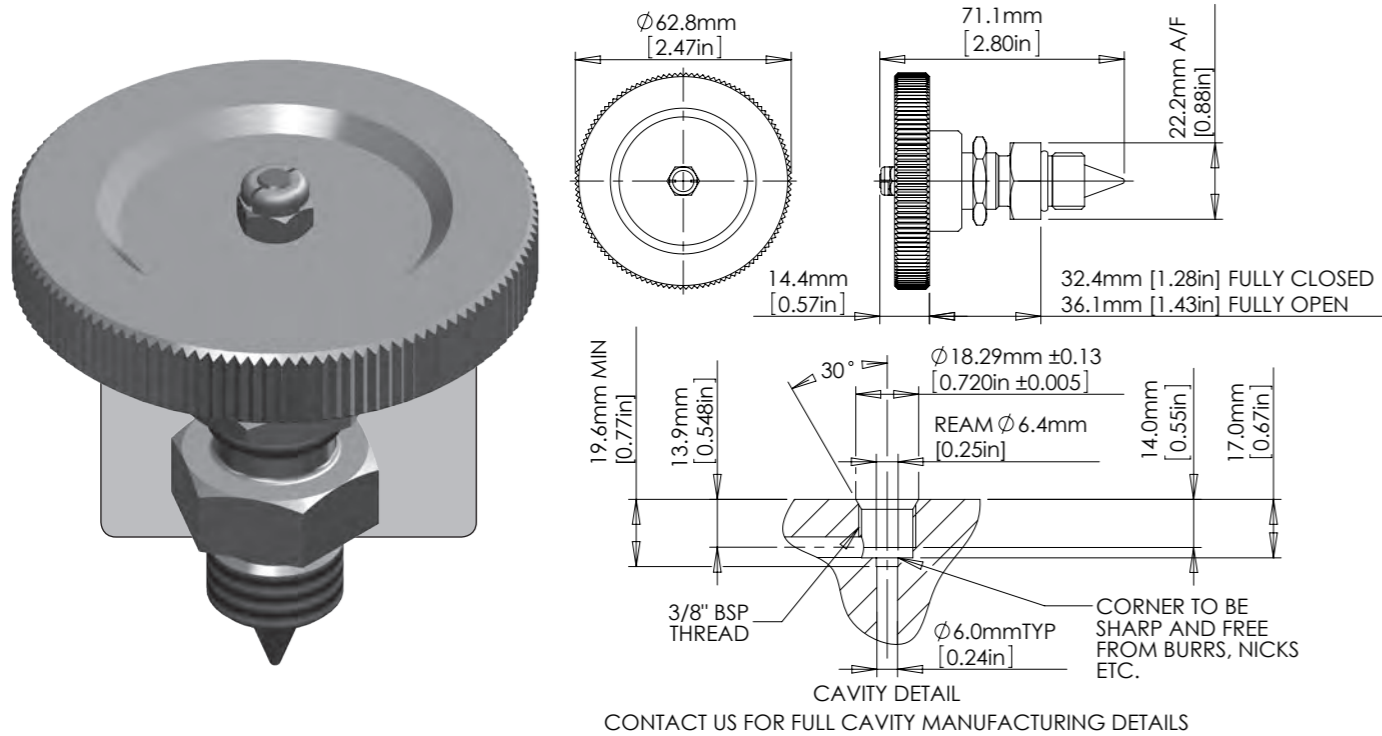

### Panel Mounted Valve

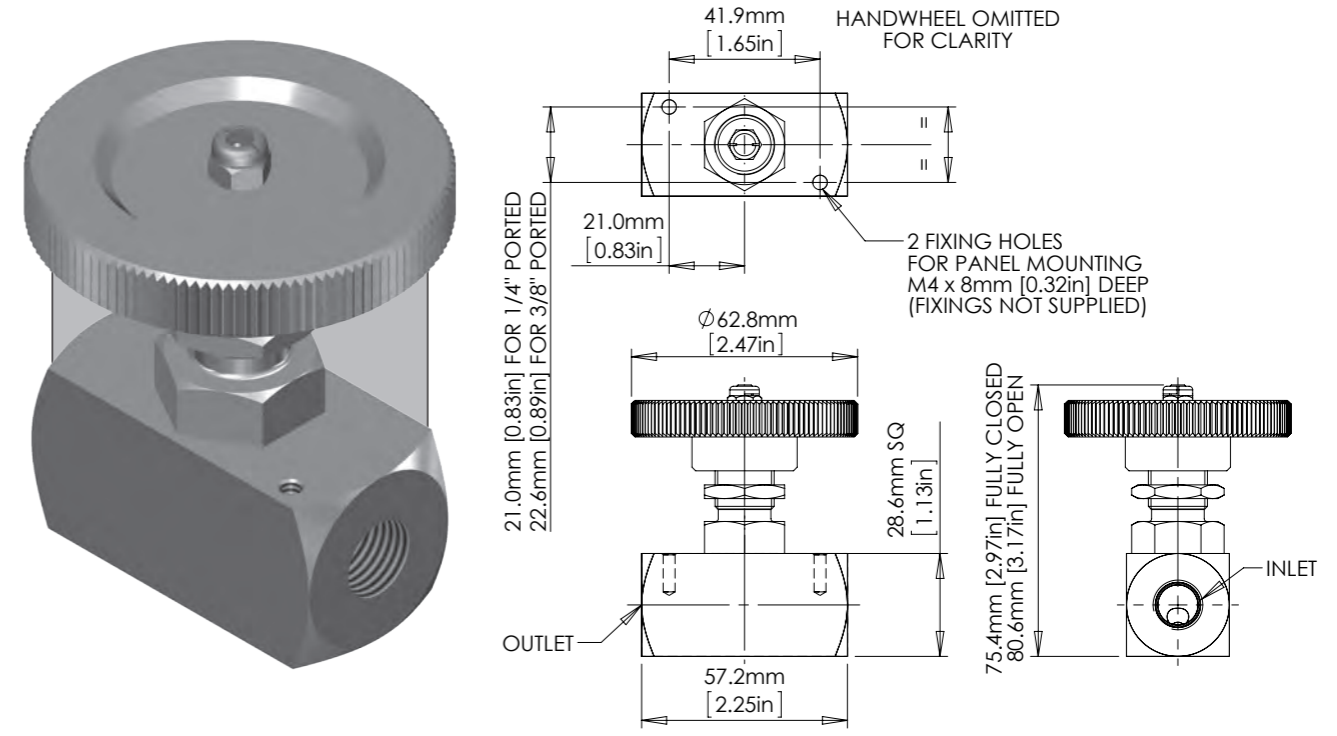

### Full Cartridge Valve

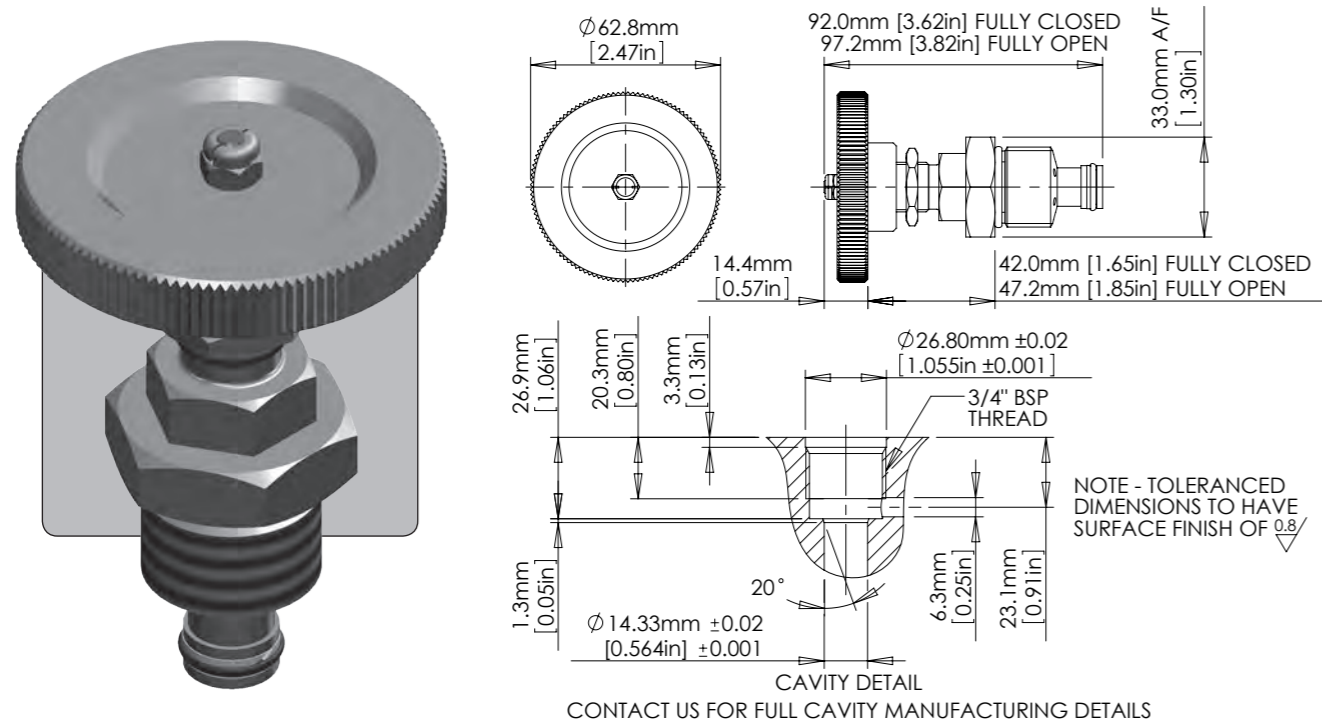

### Manifold Mount Valve

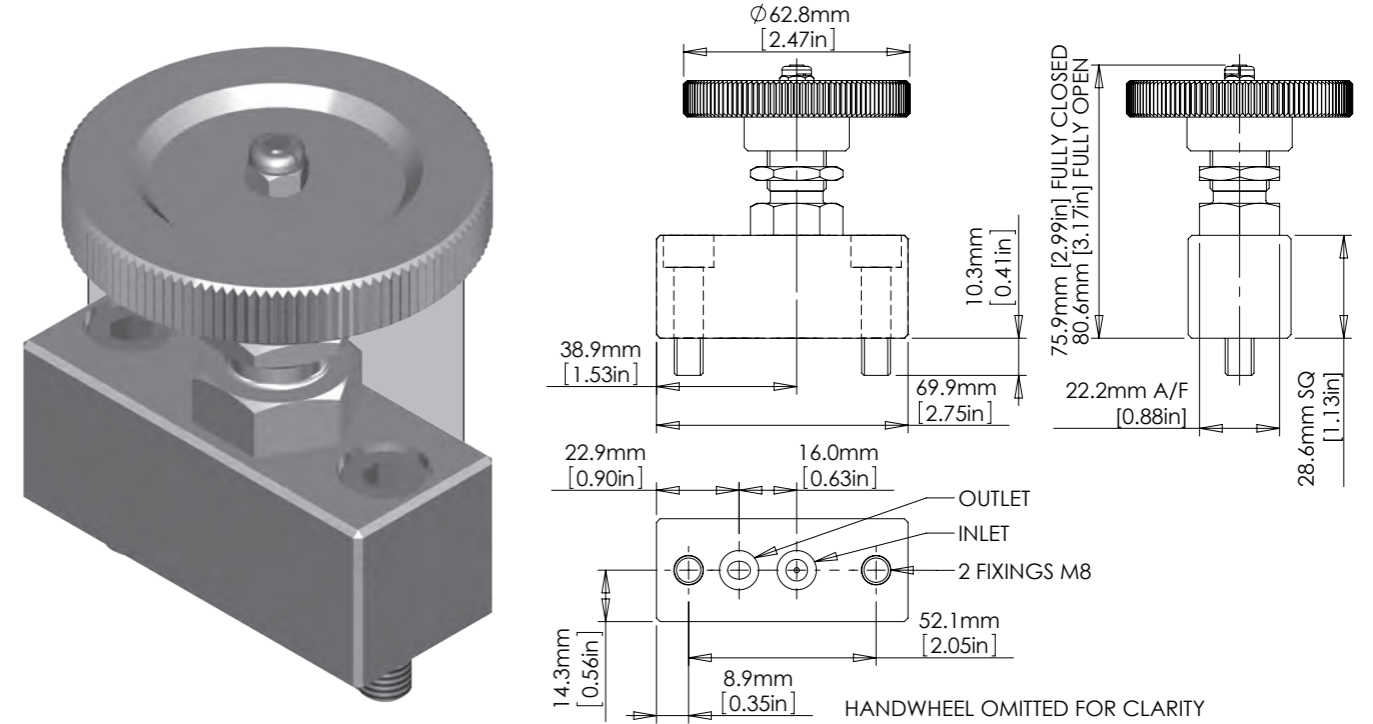

SOLENOID  
FLOW CONTROL  
3 PORT DIRECTIONAL CONTROL  
4 PORT DIRECTIONAL CONTROL  
CHECK AND SHUTTLE  
PILOT OPERATED CHECK  
RELIEF  
EXCESS FLOW  
FILTERS  
PRESSURE SENSING  
PUMPS  
ACTUATORS  
TECHNICAL DATA

# -BNV25-G-

## STOP VALVE

1/4" 3/8"

UP TO 414 BAR  
6,000 PSI

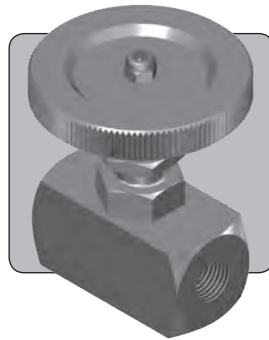

The BNV25-G is a 1/4" nominal bore stop valve. It provides tight shut-off when closed via the knurled handwheel and is soft seated allowing use with liquid or gas

Coarse adjustment allows fast operation. The valve is designed for uni-directional service only.

- Manual stop or shut-off valve for liquid or gas
- Lockable adjustment
- Panel mount option
- Non-rotating valve stem protects valve seat
- Suitable for uni-directional shut-off
- Stainless steel construction
- Suitable for use with air, nitrogen, sweet natural gas, mineral oils and water glycols
- Compatible with many other media, contact us for advice
- Subsea variant available, contact us for advice
- Various porting options available, including manifold mount and cartridge installation options
- Various seal options available

### Specifications

**BASIC MODEL NUMBER**

**BNV25-G**

**SYMBOL**

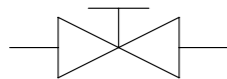

**MAX WORKING PRESSURE**

414 bar  
(6,000 psi)

**CV (FLOW CAPACITY)**

Up to 0.52  
See performance graph

**FLUID**

Liquids and Gases  
See materials section

**TEMPERATURE RANGE**

See Product Selector opposite  
and Technical Data section

**PORT SIZE**

1/4" or 3/8"

**WEIGHT**

**PORTED** 0.65 kg (1.43 lb)  
**C** 0.35 kg (0.77 lb)  
**FC** 0.50 kg (1.10 lb)

Specifications may change without notice

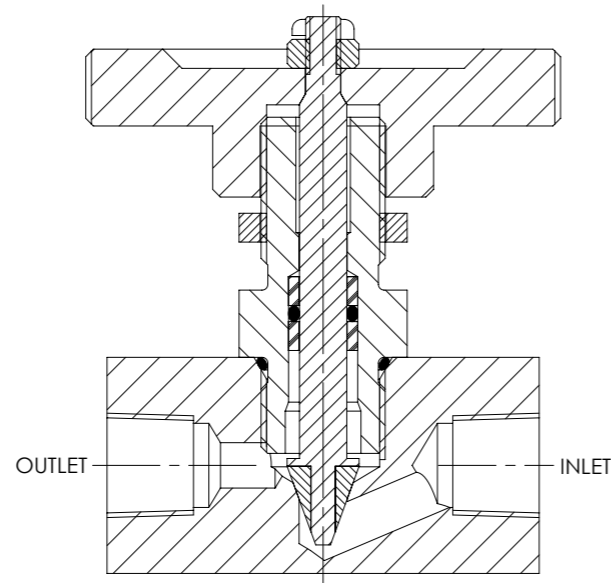

### Materials

Externally Exposed Parts: 316, 431 and other 300 series stainless steels. Electroless nickel plated bolts for the manifold mount version. Internally Wetted Parts: 316 and 431 stainless steel, polyamide-imide, acetal and PTFE.

The standard valve is designed for use with air, nitrogen, sweet natural gas, mineral oil and water glycols, but may be used with a wide variety of media compatible with the materials of construction. Other material options are available, please contact us for advice.

⚠ The standard valve has Viton® seals. Further seal options are available via the Product Selector. Compatibility with the working fluid at the operating temperature must be considered.

### Typical Performance

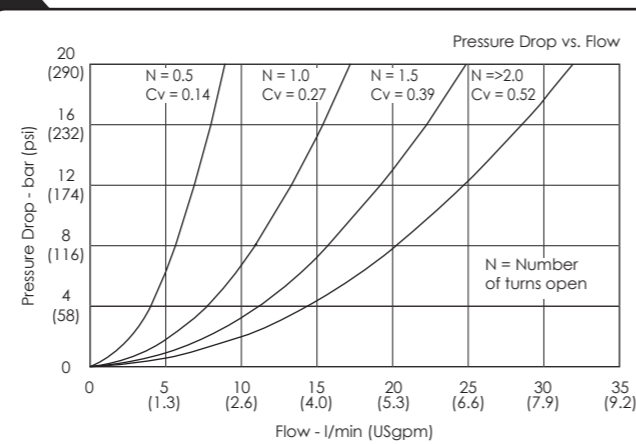

Typical performance based on water glycol

### Installation Diagram

STANDARD VALVE

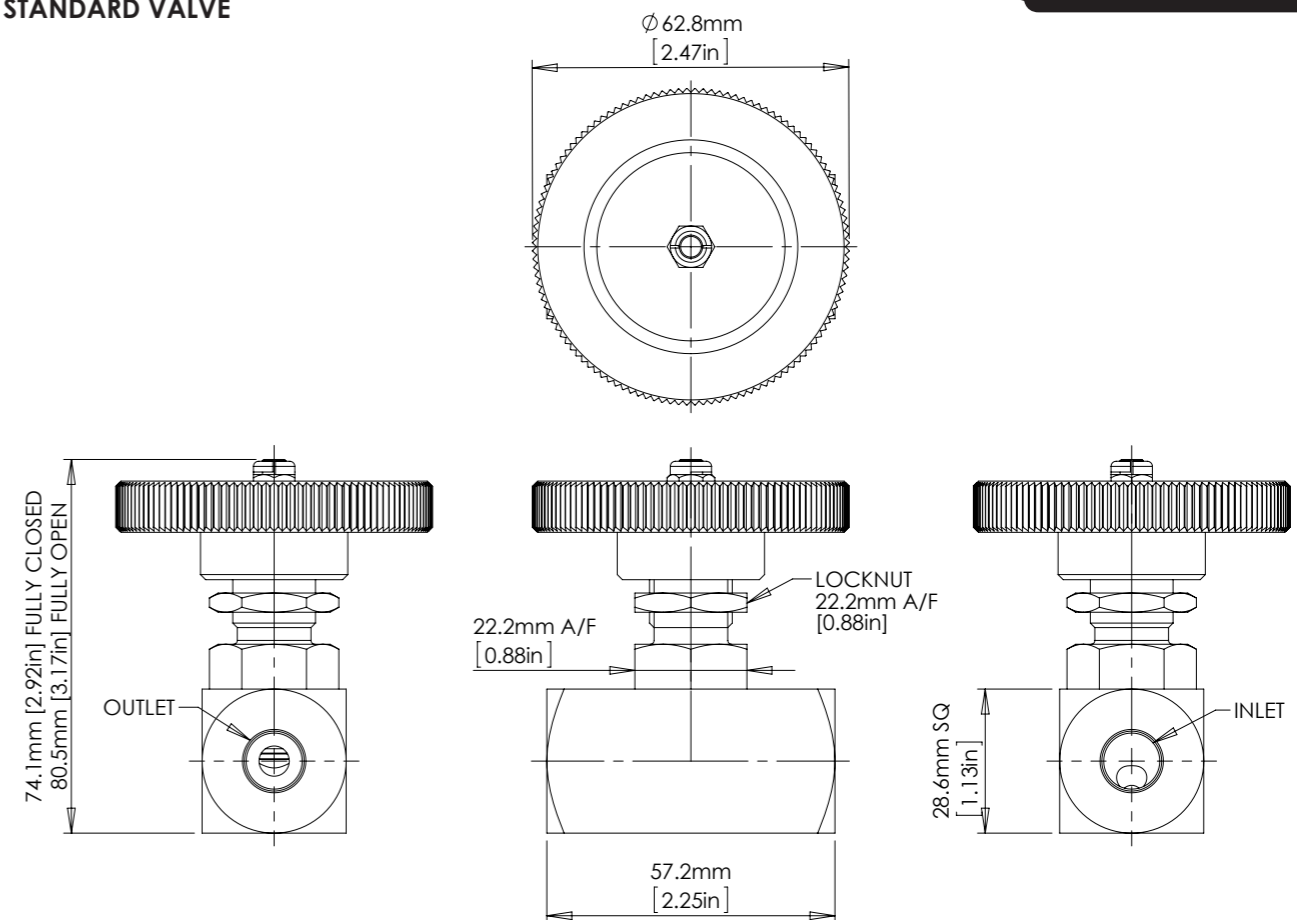

### Product Selector

BNV25 P - G - PM - NBR - 6K

VALVE TYPE	PORTING OPTIONS	SEAT TYPE	VALVE OPTIONS	SEAL OPTIONS	MAX WORKING PRESSURE
<b>BNV25</b>	<b>P</b> 1/4" BSPP female <b>N</b> 1/4" NPT female <b>/37P</b> 3/8" BSPP female <b>/37N</b> 3/8" NPT female <b>M</b> Manifold mount <b>C</b> Cartridge style Seat in cavity <b>FC</b> Full cartridge Seat in cartridge	<b>G</b> Soft seats	<b>PM</b> Panel mounted Not available for manifold or cartridge versions	<b>NBR</b> Nitrile seals -30°C to +105°C <b>EP</b> EPDM seals -45°C to +120°C <b>KLZ</b> Kalrez® seals -25°C to +120°C <b>HNBR</b> Hydrogenated Nitrile seals -20°C to +120°C	<b>6K</b> 414 bar (6,000 psi)
Repair and seal kits are available on request		G option must be selected		Leave blank for Viton® seals -10°C to +120°C	
For a seal kit add SK at the end of the model code and for a repair kit add RK		Leave blank if not required		Further seal options are available on request	
⚠ Exposure to high and low fluid temperatures will influence handle temperature. Operator safety must be considered					



Catalogue also available on digital media  
Visit our website for a full online search facility  
[www.bisvalves.co.uk](http://www.bisvalves.co.uk)



**BS VALVES**  
The Specifier's Catalogue

SOLENOID  
FLOW CONTROL  
3 PORT DIRECTIONAL CONTROL  
4 PORT DIRECTIONAL CONTROL  
CHECK AND SHUTTLE  
PILOT OPERATED CHECK  
RELIEF  
EXCESS FLOW  
FILTERS  
PRESSURE SENSING  
PUMPS  
ACTUATORS  
TECHNICAL DATA



# BNV25 -G

## STOP VALVE

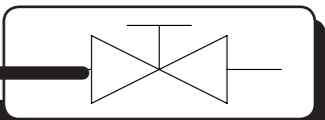

### Cartridge Valve

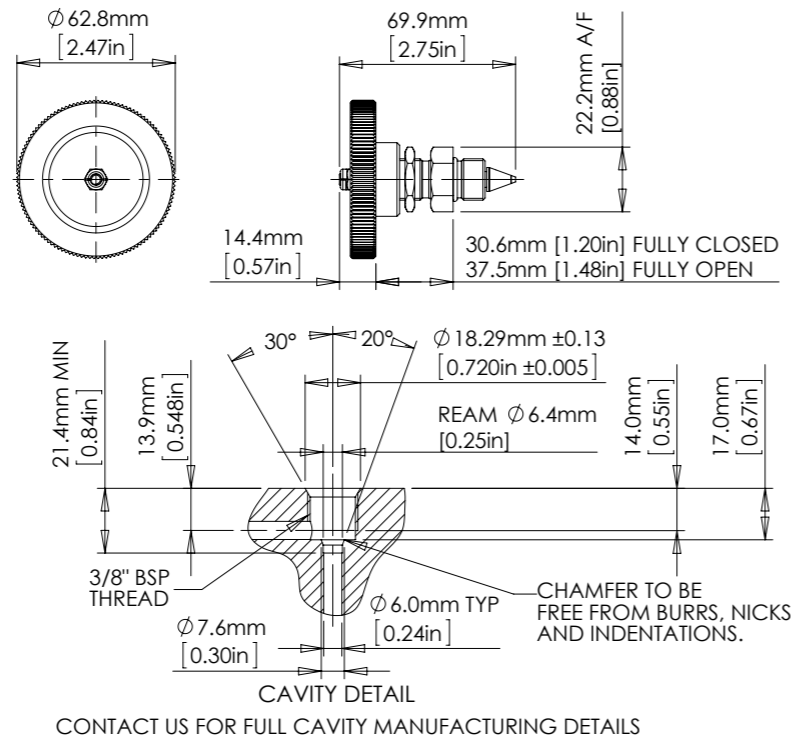
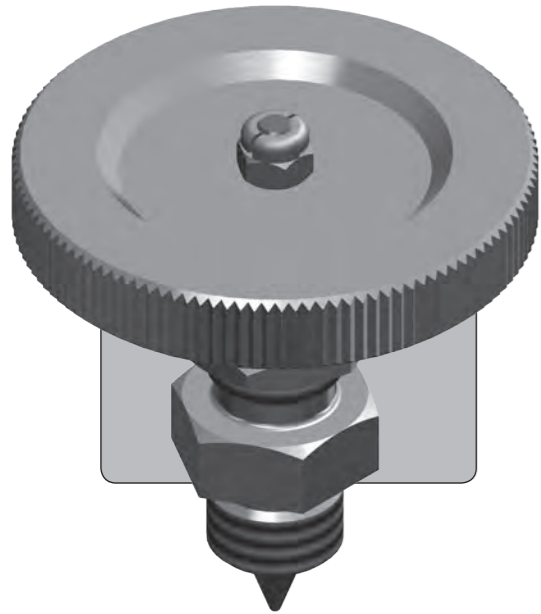

### Panel Mounted Valve

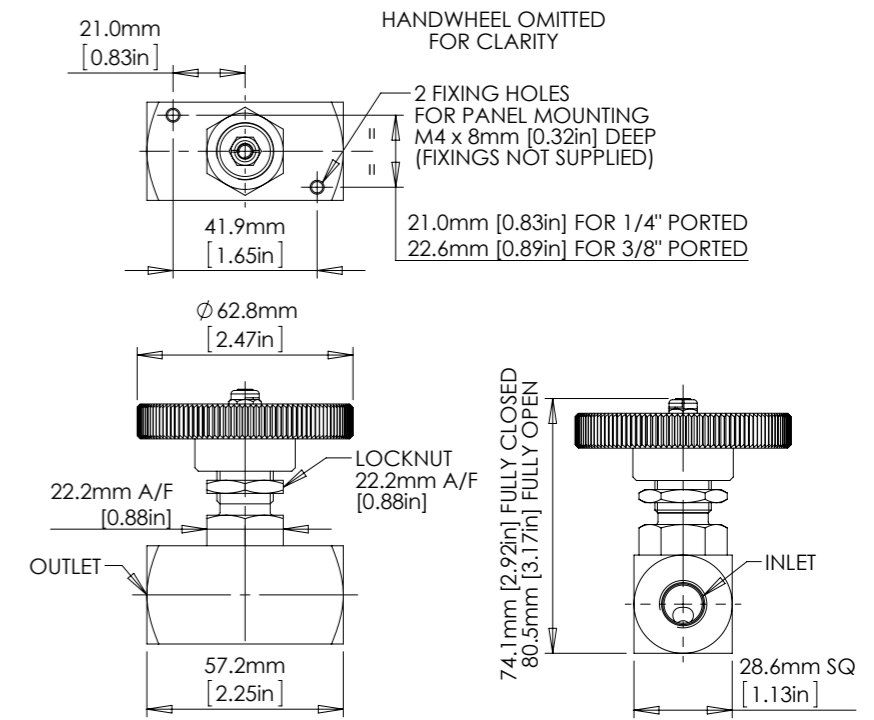
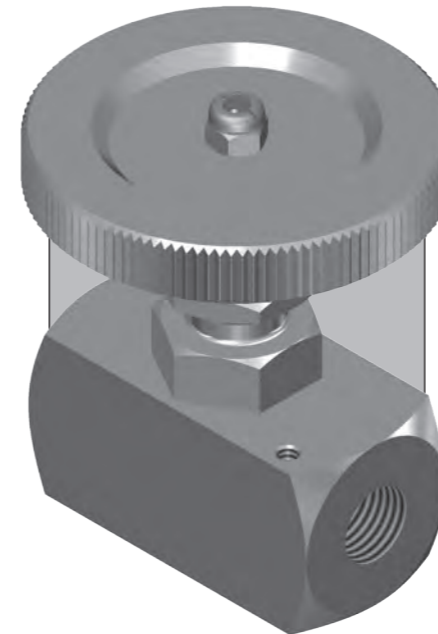

### Full Cartridge Valve

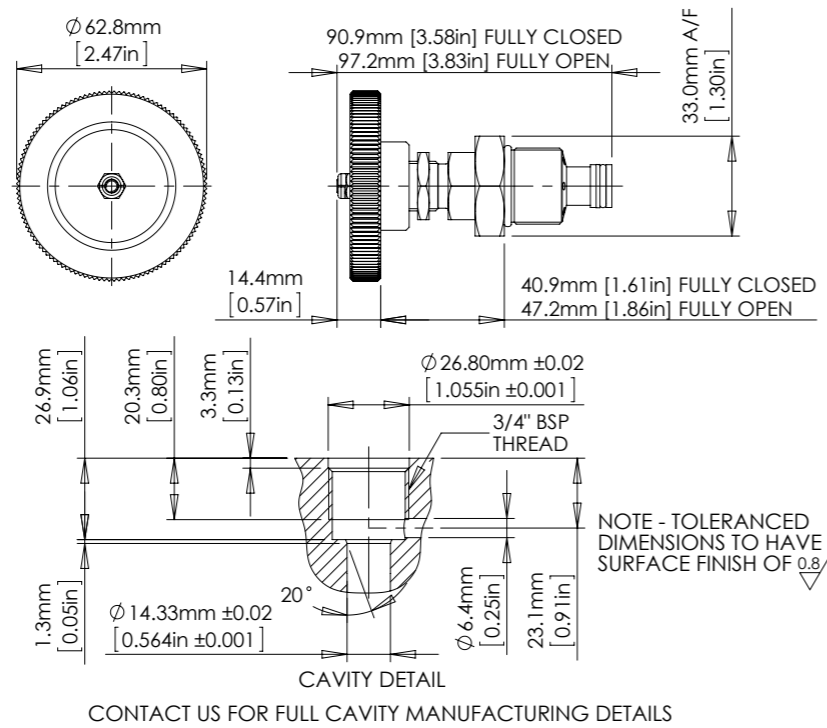
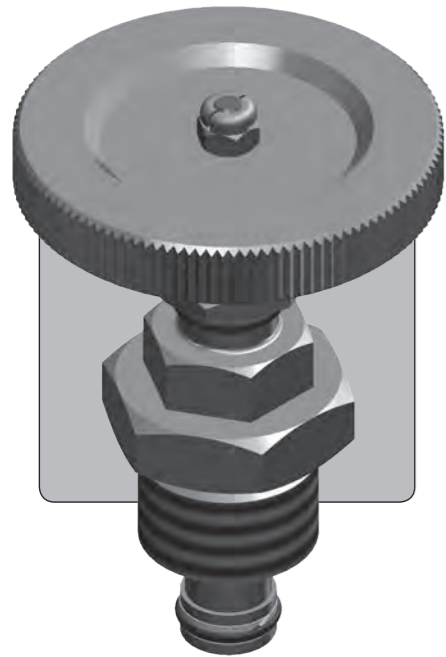

### Manifold Mount Valve

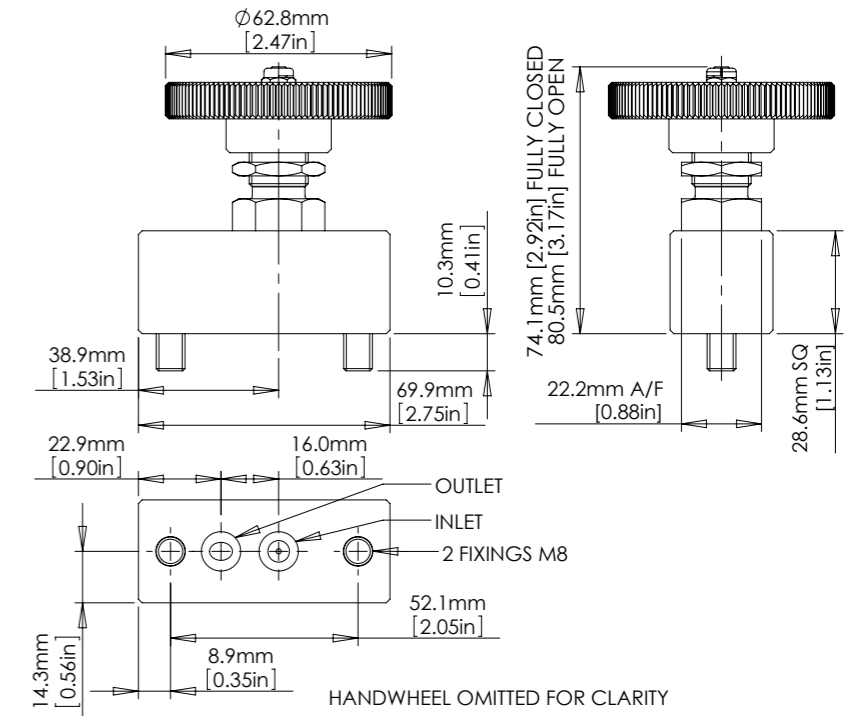
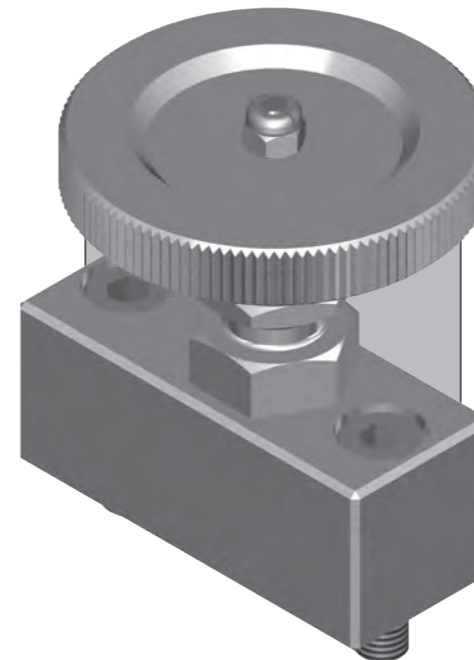

- SOLENOID
- FLOW CONTROL
- 3 PORT DIRECTIONAL CONTROL
- 4 PORT DIRECTIONAL CONTROL
- CHECK AND SHUTTLE
- PILOT OPERATED CHECK
- RELIEF
- EXCESS FLOW
- FILTERS
- PRESSURE SENSING
- PUMPS
- ACTUATORS
- TECHNICAL DATA

# -BNV25-TB-

## STOP VALVE

1/4" 3/8"

UP TO 862 BAR  
12,500 PSI



The BNV25-TB is a 1/4" nominal bore stop valve. It provides tight shut-off when closed via a T-bar handle.

Coarse adjustment allows fast operation. For uni-directional service, the valve is marked with a preferred direction of flow, but the valve may be used with the same functionality in the opposite direction.

- Manual stop or shut-off valve
- Lockable adjustment
- Panel mount option
- Non-rotating valve stem protects valve seat
- Suitable for uni-directional or bi-directional shut-off
- Stainless steel construction
- Suitable for use with mineral oils, water glycols and plain water
- Compatible with many other media, contact us for advice
- All wetted parts comply with NACE MR01-75
- Various porting options available, including manifold mount and cartridge installation options
- Various seal options available

### Specifications

**BASIC MODEL NUMBER**

**BNV25-TB**

**SYMBOL**

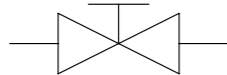

**MAX WORKING PRESSURE**

862 bar  
(12,500 psi)

**CV (FLOW CAPACITY)**

Up to 0.75  
See performance graph

**FLUID**

Liquids only  
See materials section

**TEMPERATURE RANGE**

See Product Selector opposite  
and Technical Data section

**PORT SIZE**

1/4" or 3/8"

**WEIGHT**

**PORTED** 0.79 kg (1.73 lb)  
**C** 0.23 kg (0.50 lb)  
**FC** 0.48 kg (1.05 lb)

Specifications may change without notice

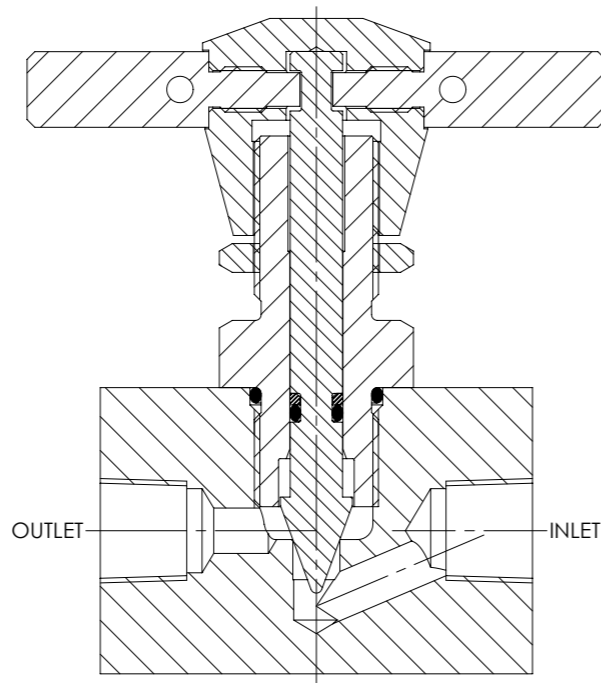

### Materials

Externally Exposed Parts: 316 stainless steel and aluminium bronze. Electroless nickel plated bolts for the manifold mount version. Internally Wetted Parts: 316 and 17-4 PH stainless steel and acetal.

The standard valve is designed for use with mineral oil, water glycols and plain water, but may be used with a wide variety of media compatible with the materials of construction. Other material options are available, please contact us for advice.

⚠ The standard valve has Viton® seals. Further seal options are available via the Product Selector. Compatibility with the working fluid at the operating temperature must be considered.

### Typical Performance

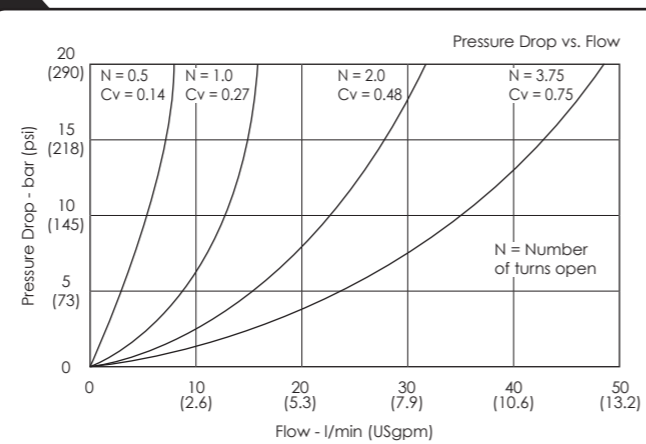

Typical performance based on water

### Installation Diagram

STANDARD VALVE

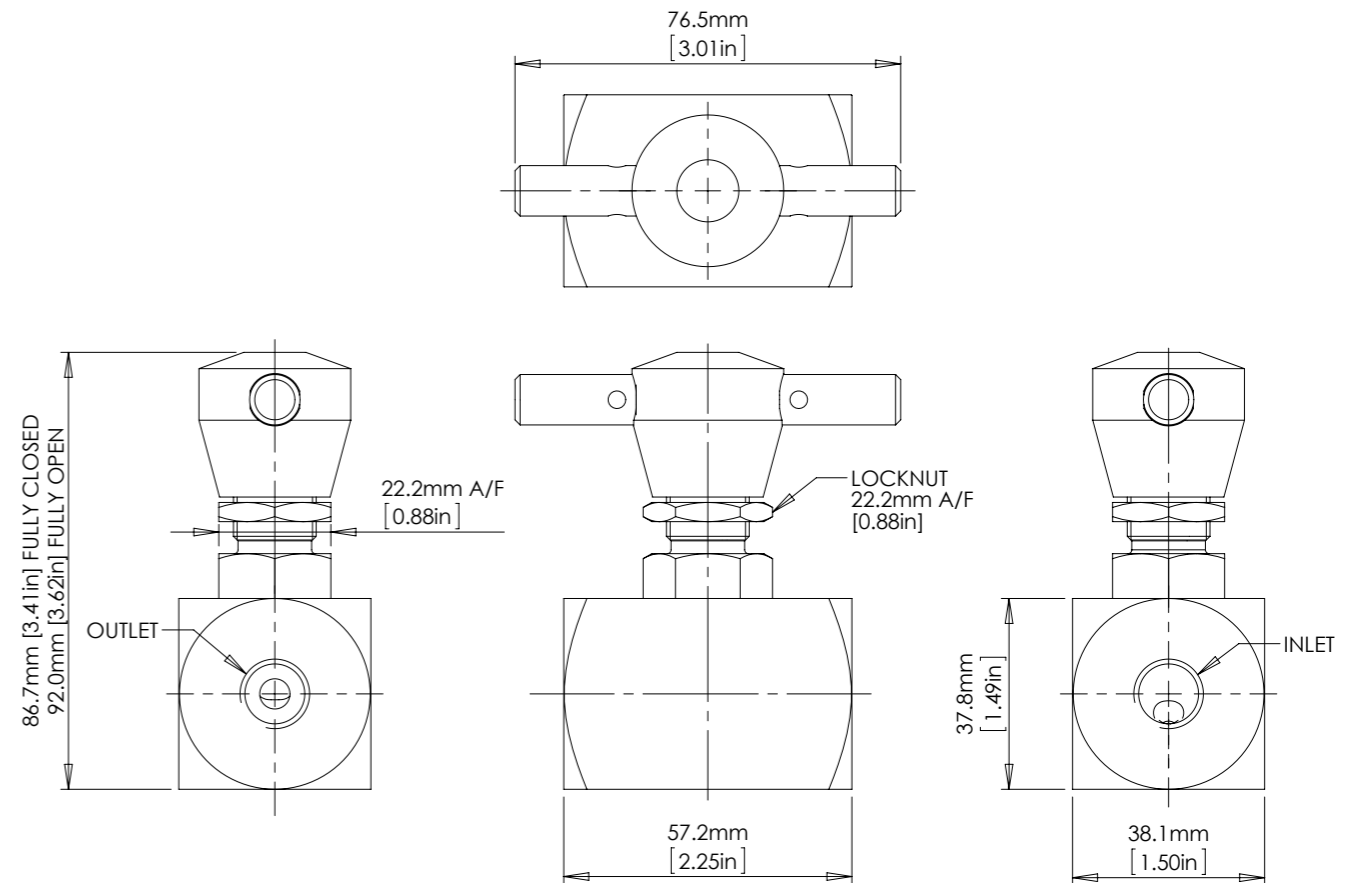

### Product Selector

BNV25 P - TB - PM - NBR - 12.5K

VALVE TYPE	PORTING OPTIONS	HANDLE TYPE	VALVE OPTIONS	SEAL OPTIONS	MAX WORKING PRESSURE
BNV25	<b>P</b> 1/4" BSPP female <b>N</b> 1/4" NPT female <b>/37P</b> 3/8" BSPP female <b>/37N</b> 3/8" NPT female <b>M</b> Manifold mount <b>C</b> Cartridge style Seat in cavity <b>FC</b> Full cartridge Seat in cartridge	<b>TB</b> T-bar handle <small>TB option must be selected</small>	<b>PM</b> Panel mounted <small>Leave blank if not required</small> Not available for manifold or cartridge versions	<b>NBR</b> Nitrile seals -10°C to +120°C <b>EP</b> EPDM seals -45°C to +120°C <b>KLZ</b> Kalrez® seals -25°C to +120°C <b>HNBR</b> Hydrogenated Nitrile seals -20°C to +120°C <small>Further seal options are available on request</small> ⚠ Exposure to high and low fluid temperatures will influence handle temperature. Operator safety must be considered.	<b>12.5K</b> 862 bar (12,500 psi) Liquid



Catalogue also available on digital media  
Visit our website for a full online search facility  
[www.bisvalves.co.uk](http://www.bisvalves.co.uk)



**BS VALVES**  
The Specifier's Catalogue

SOLENOID  
FLOW CONTROL  
3 PORT DIRECTIONAL CONTROL  
4 PORT DIRECTIONAL CONTROL  
CHECK AND SHUTTLE  
PILOT OPERATED CHECK  
RELIEF  
EXCESS FLOW  
FILTERS  
PRESSURE SENSING  
PUMPS  
ACTUATORS  
TECHNICAL DATA

# BNV25 -TB

## STOP VALVE

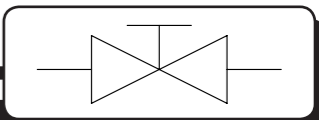

### Cartridge Valve

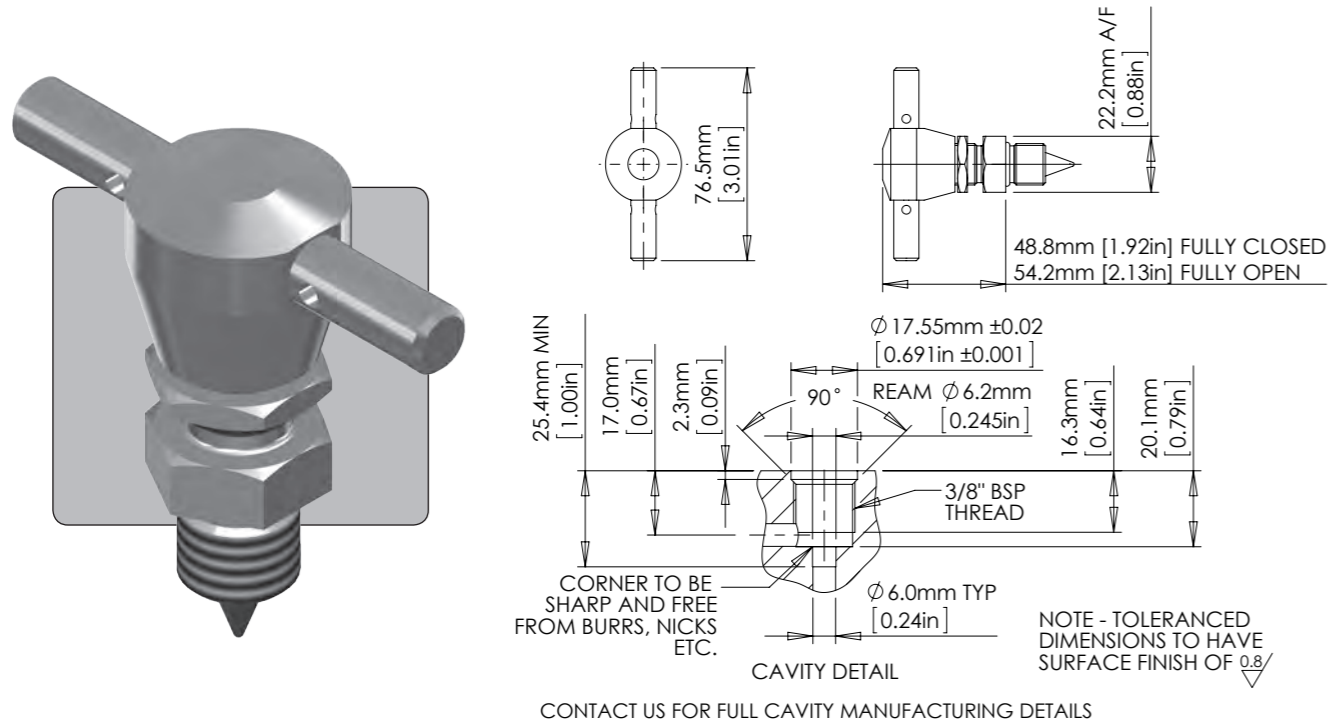

### Panel Mounted Valve

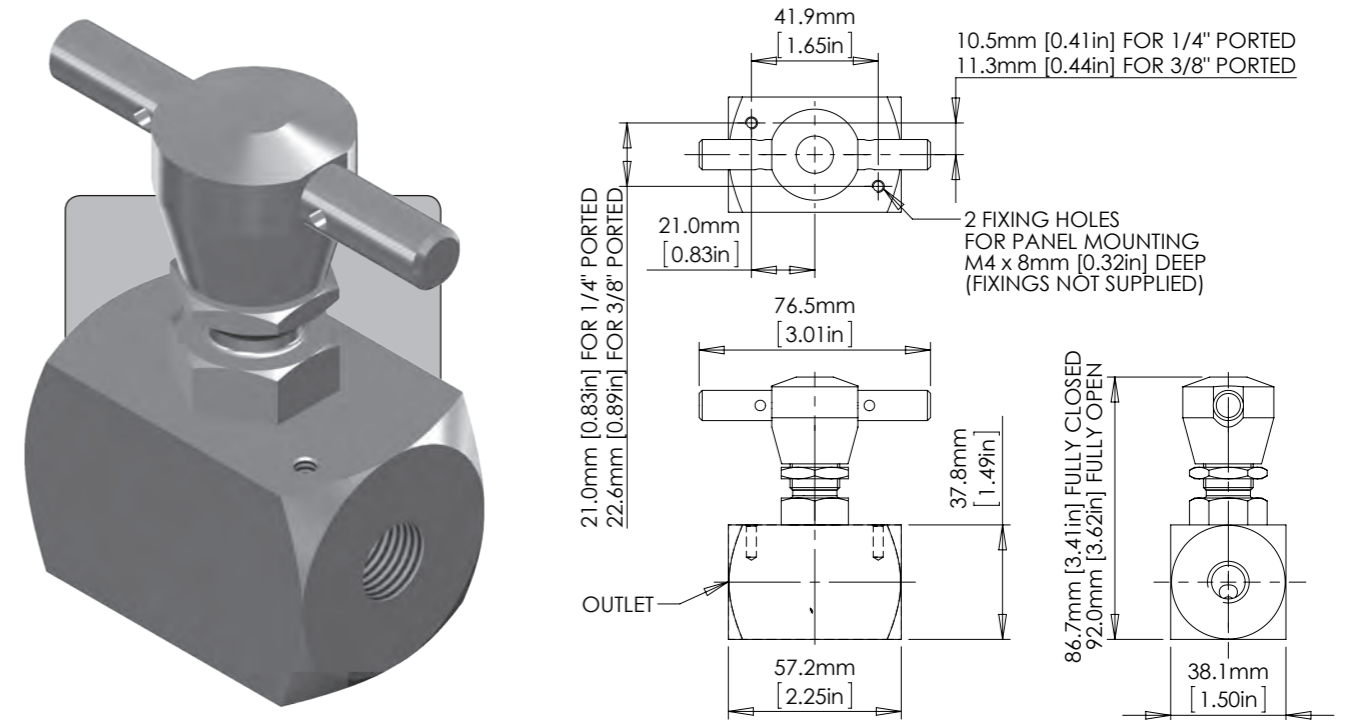

### Full Cartridge Valve

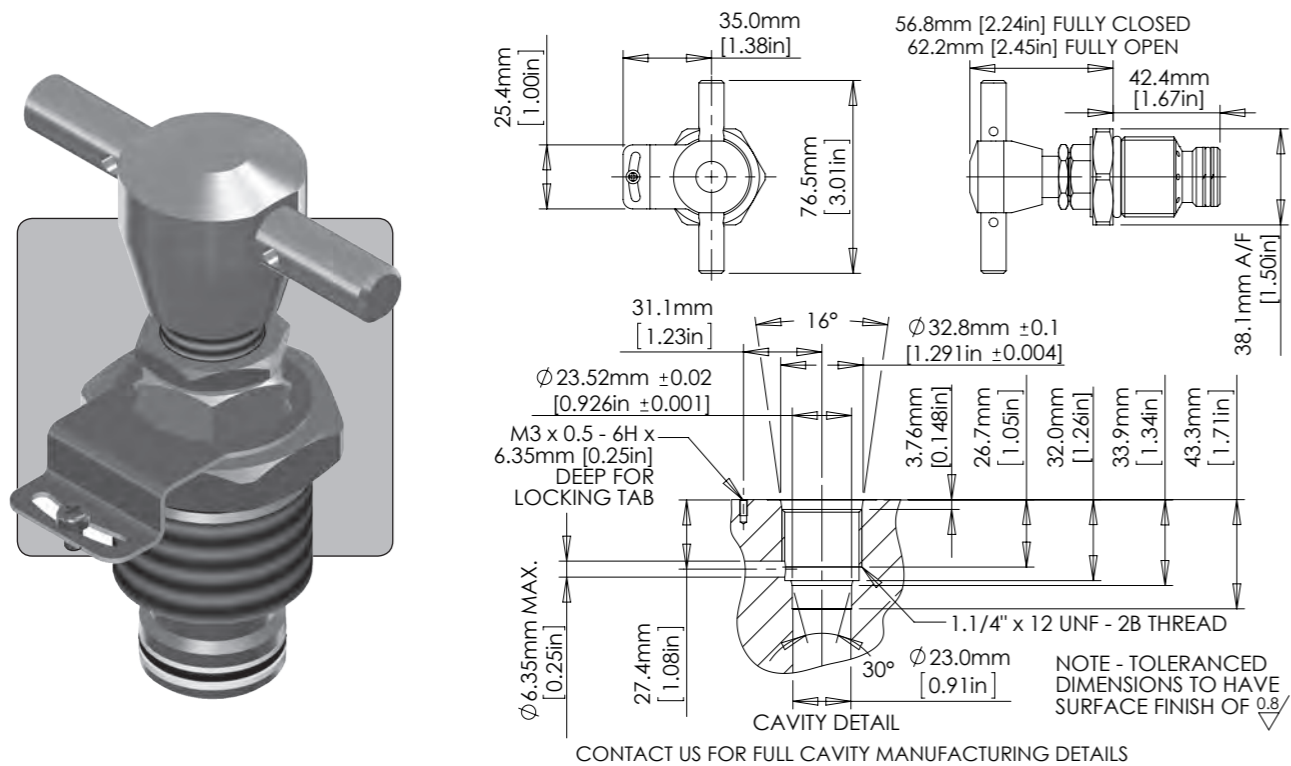

### Manifold Mount Valve

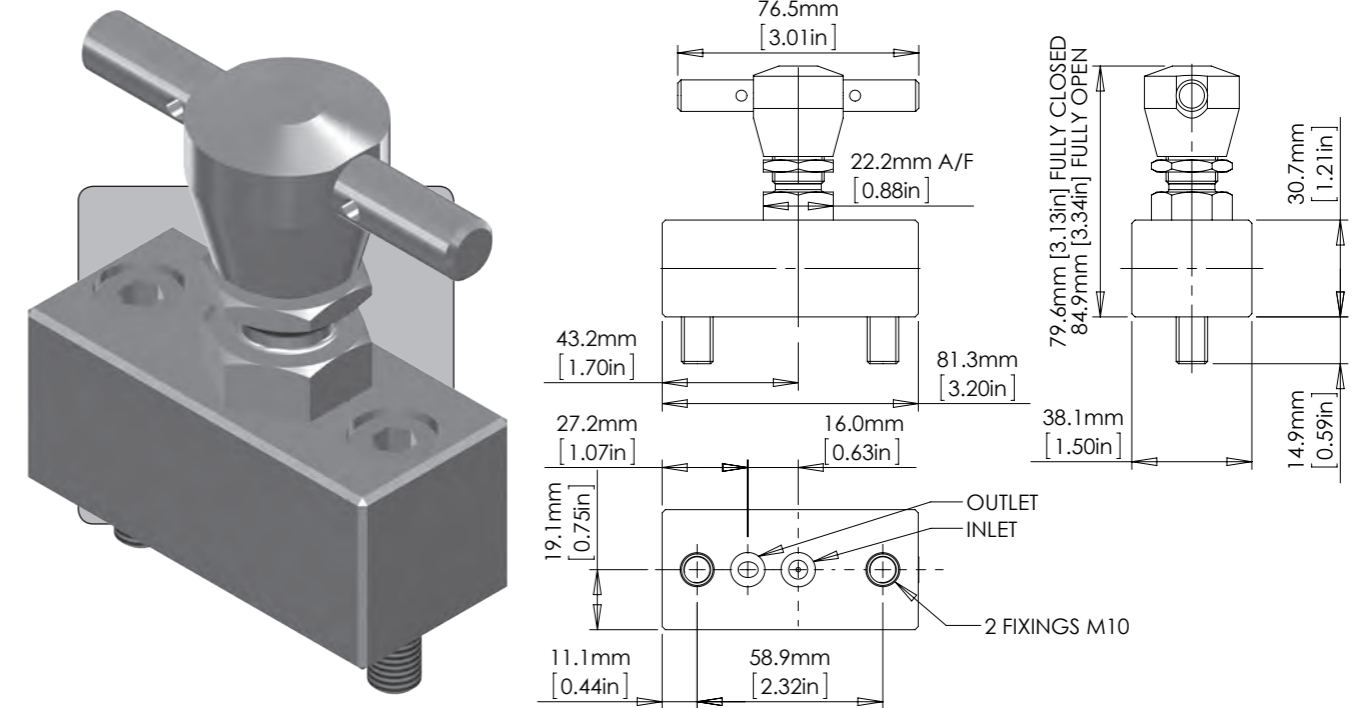

- SOLENOID
- FLOW CONTROL
- 3 PORT DIRECTIONAL CONTROL
- 4 PORT DIRECTIONAL CONTROL
- CHECK AND SHUTTLE
- PILOT OPERATED CHECK
- RELIEF
- EXCESS FLOW
- FILTERS
- PRESSURE SENSING
- PUMPS
- ACTUATORS
- TECHNICAL DATA

# BNV50 STOP VALVE

1/2" 3/4"

UP TO 690 BAR  
10,000 PSI

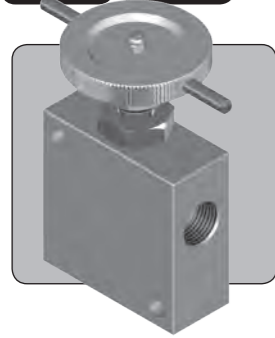

The BNV50 is a 1/2" nominal bore stop valve. It provides tight shut-off when closed via the knurled handwheel with extension bars.

Coarse adjustment allows fast operation. For uni-directional service, the valve is marked with a preferred direction of flow, but the valve may be used with the same functionality in the opposite direction.

- Manual stop or shut-off valve
- Lockable adjustment
- Panel mount option
- Non-rotating valve stem protects valve seat
- Suitable for uni-directional or bi-directional shut-off
- Stainless steel construction
- Suitable for use with mineral oils and water glycols
- Compatible with many other media, contact us for advice
- Cartridge version available, contact us for details
- Various porting options available
- Various seal options available

## Specifications

BASIC MODEL NUMBER

**BNV50**

SYMBOL

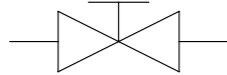

MAX WORKING PRESSURE

690 bar  
(10,000 psi)

CV (FLOW CAPACITY)

Up to 2.1  
See performance graph

FLUID

Liquids only  
See materials section

TEMPERATURE RANGE

See Product Selector opposite  
and Technical Data section

PORT SIZE

1/2" or 3/4"

WEIGHT

1.7 kg  
(3.7 lb)

Specifications may change without notice

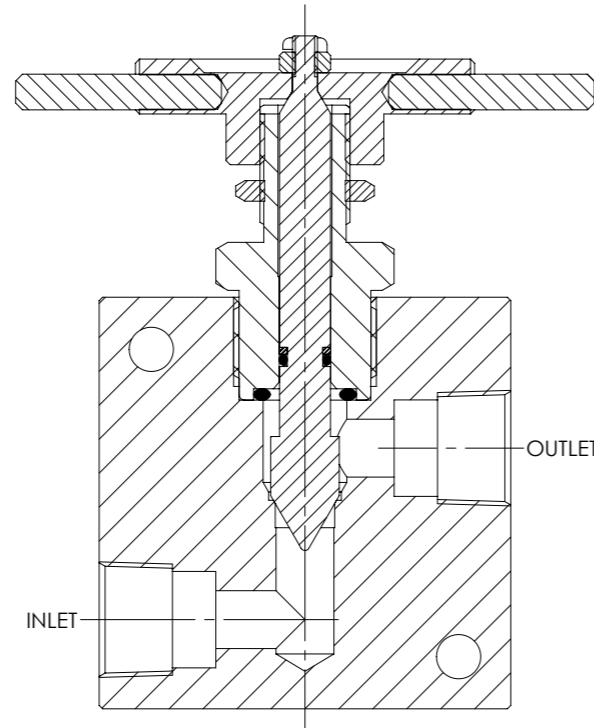

## Materials

Externally Exposed Parts: 316, 440C and other 300 series stainless steels.  
Internally Wetted Parts: 316 and 440C stainless steel and acetal.

The standard valve is designed for use with mineral oil and water glycols, but may be used with a wide variety of media compatible with the materials of construction. Other material options are available, please contact us for advice.

⚠ The standard valve has Viton® seals. Further seal options are available via the Product Selector. Compatibility with the working fluid at the operating temperature must be considered.

## Typical Performance

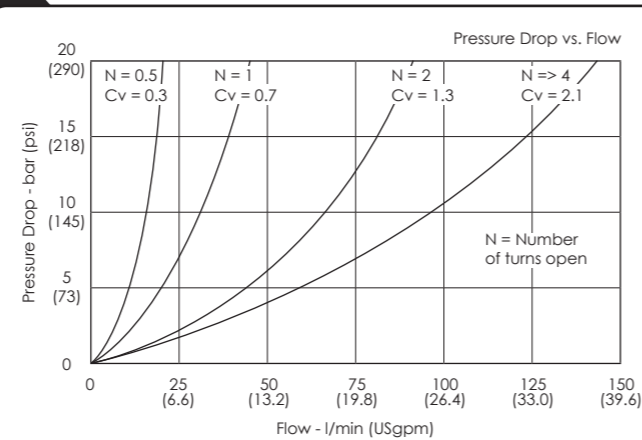

Typical performance based on water glycol

## Installation Diagram

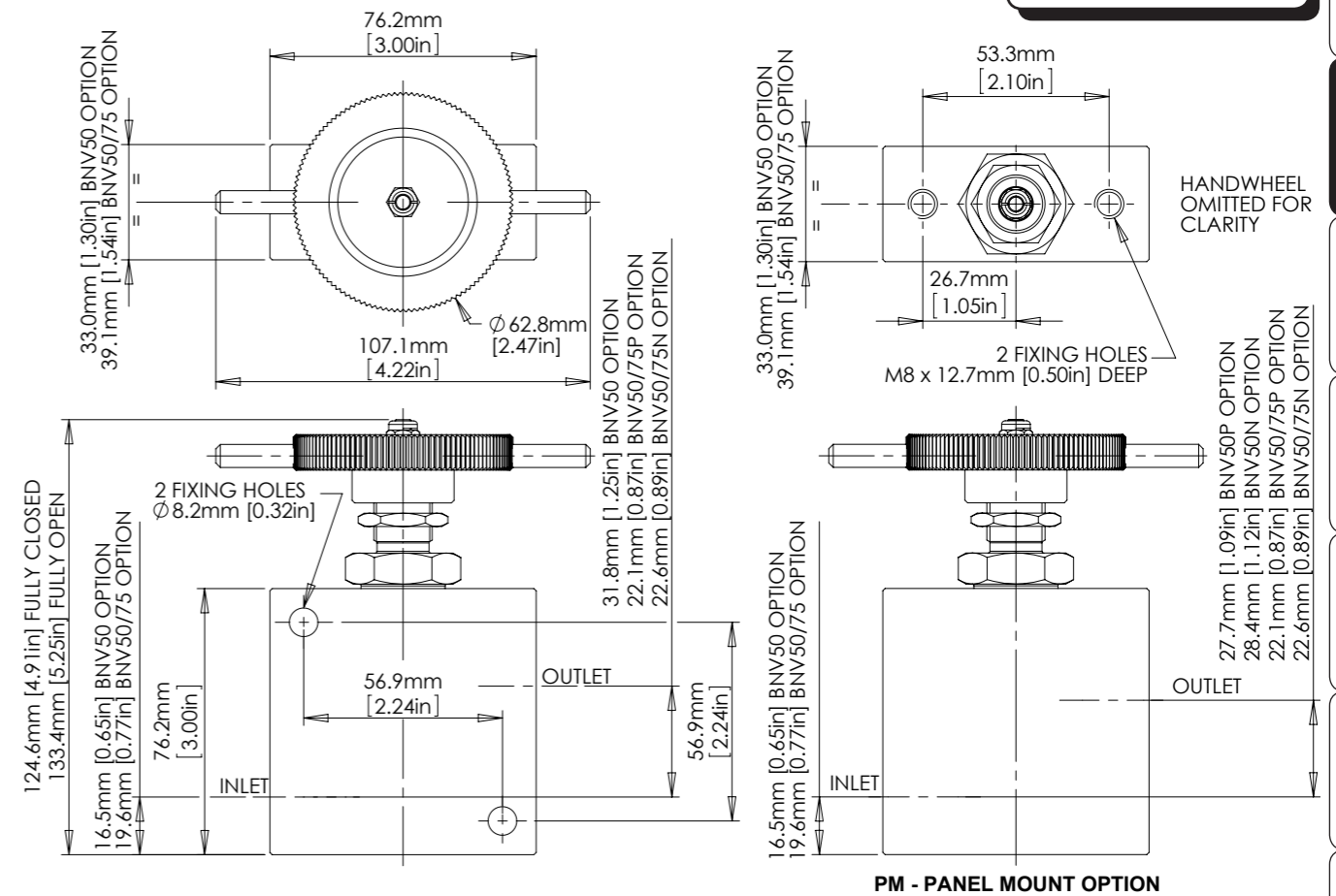

## Product Selector

### BNV50 P - PM - NBR - 10K

VALVE TYPE	PORTING OPTIONS	VALVE OPTIONS	SEAL OPTIONS	MAX WORKING PRESSURE
<b>BNV50</b>	<b>P</b> 1/2" BSPP female	<b>PM</b> Panel mounted	<b>NBR</b> Nitrile seals -30°C to +105°C	<b>10K</b> 690 bar (10,000 psi) Liquid
	<b>N</b> 1/2" NPT female		<b>KLZ</b> Kalrez® seals -25°C to +120°C	
	<b>/75P</b> 3/4" BSPP female		<b>HNBR</b> Hydrogenated Nitrile seals -20°C to +120°C	
	<b>/75N</b> 3/4" NPT female		Further seal options are available on request	

Repair and seal kits are available on request

For a seal kit add SK at the end of the model code and for a repair kit add RK

⚠ Exposure to high and low fluid temperatures will influence handle temperature. Operator safety must be considered.



Catalogue also available on digital media  
Visit our website for a full online search facility  
[www.bisvalves.co.uk](http://www.bisvalves.co.uk)



**BS VALVES**  
The Specifier's Catalogue

SOLENOID  
FLOW CONTROL  
3 PORT DIRECTIONAL CONTROL  
4 PORT DIRECTIONAL CONTROL  
CHECK AND SHUTTLE  
PILOT OPERATED CHECK  
RELIEF  
EXCESS FLOW  
FILTERS  
PRESSURE SENSING  
PUMPS  
ACTUATORS  
TECHNICAL DATA

# -BNV50-G-

## STOP VALVE

1/2" 3/4"

UP TO 414 BAR  
6,000 PSI

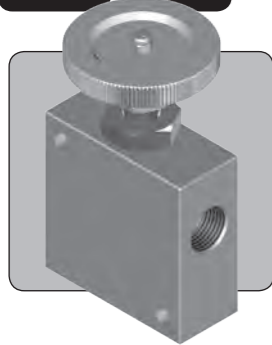

The BNV50-G is a 1/2" nominal bore stop valve. It provides tight shut-off when closed via the knurled handwheel and is soft seated allowing use with liquid or gas.

Coarse adjustment allows fast operation. The valve is designed for uni-directional service only.

- Manual stop or shut-off valve for liquid or gas
- Lockable adjustment
- Panel mount option
- Non-rotating valve stem protects valve seat
- Suitable for uni-directional shut-off
- Stainless steel construction
- Suitable for use with air, nitrogen, sweet natural gas, mineral oils and water glycols
- Compatible with many other media, contact us for advice
- Cartridge version available, contact us for details
- Various porting options available
- Various seal options available

### Specifications

BASIC MODEL NUMBER

**BNV50-G**

SYMBOL

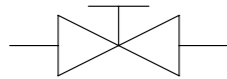

MAX WORKING PRESSURE

414 bar  
(6,000 psi)

CV (FLOW CAPACITY)

Up to 2.1  
See performance graph

FLUID

Liquids and Gases  
See materials section

TEMPERATURE RANGE

See Product Selector opposite and Technical Data section

PORT SIZE

1/2" or 3/4"

WEIGHT

1.7 kg  
(3.7 lb)

Specifications may change without notice

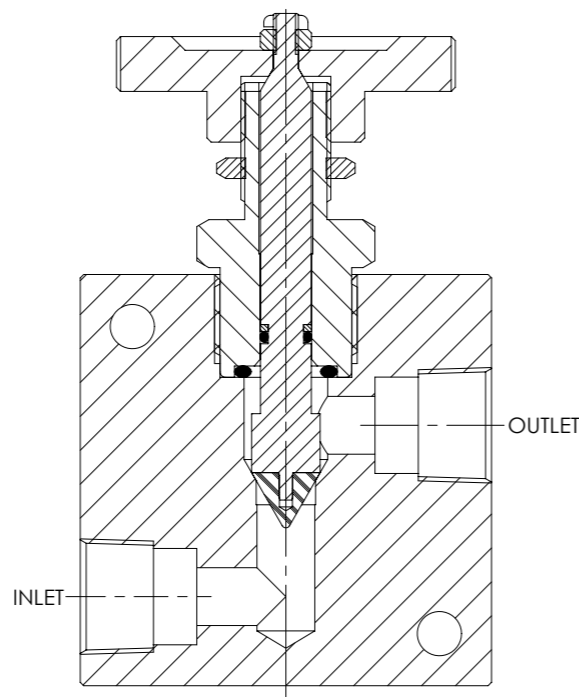

### Materials

Externally Exposed Parts: 316, 431 and other 300 series stainless steels.  
Internally Wetted Parts: 316 and 431 stainless steel, polyamide-imide and acetal.

The standard valve is designed for use with air, nitrogen, sweet natural gas, mineral oil and water glycols but may be used with a wide variety of media compatible with the materials of construction. Other material options are available, please contact us for advice.

⚠ The standard valve has Viton® seals. Further seal options are available via the Product Selector. Compatibility with the working fluid at the operating temperature must be considered.

### Typical Performance

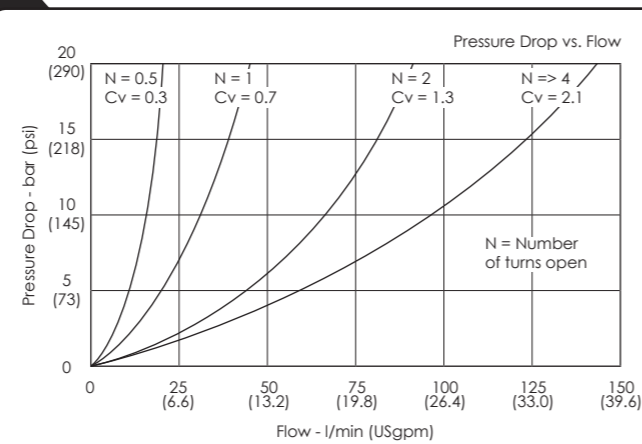

Typical performance based on water glycol

### Installation Diagram

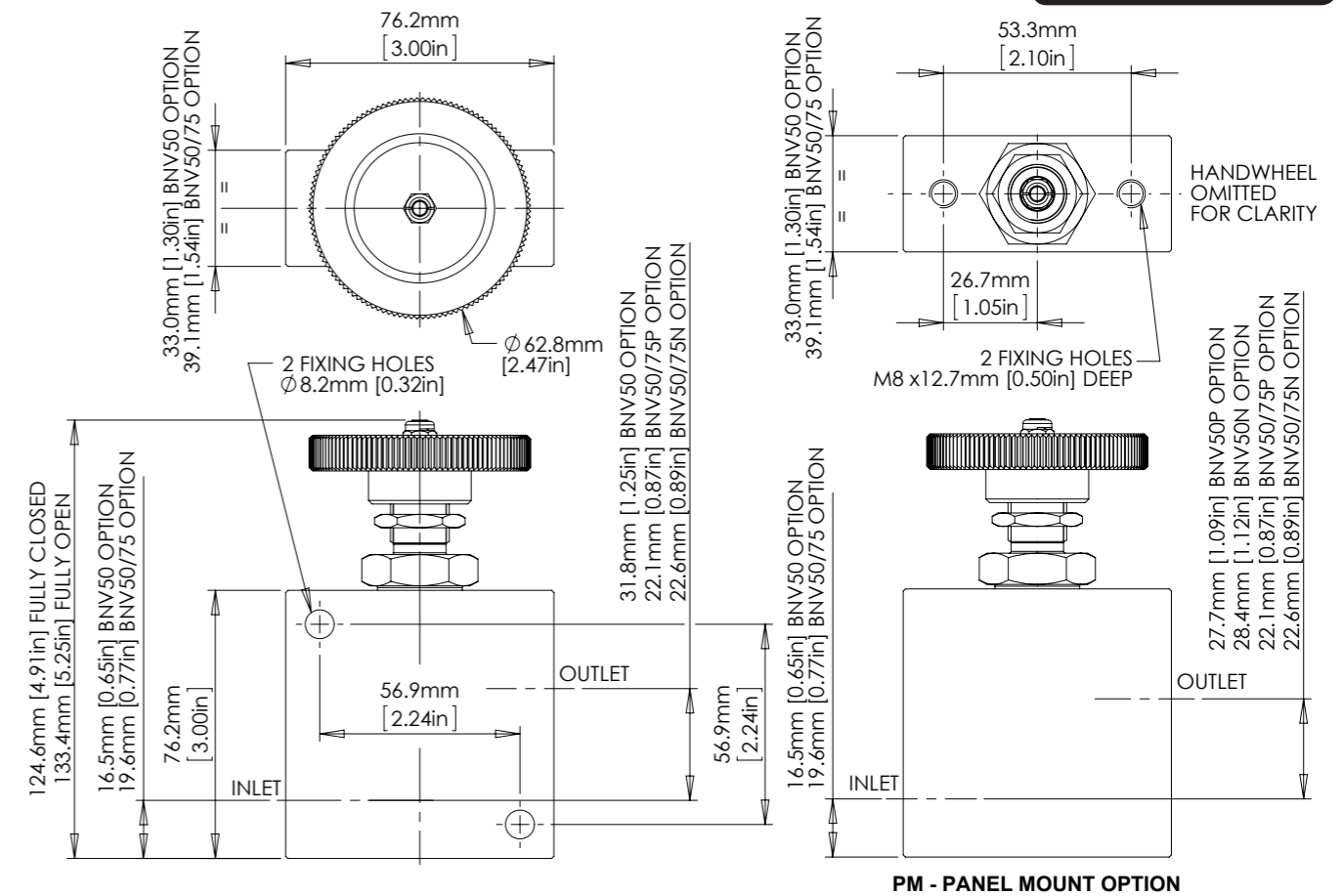

### Product Selector

BNV50 P - G - PM - NBR - 6K

VALVE TYPE	PORTING OPTIONS	SEAT TYPE	VALVE OPTIONS	SEAL OPTIONS	MAX WORKING PRESSURE
BNV50	<b>P</b> 1/2" BSPP female	<b>G</b> Soft seats	<b>PM</b> Panel mounted	<b>NBR</b> Nitrile seals -30°C to +105°C	<b>6K</b> 414 bar (6,000 psi)
	<b>N</b> 1/2" NPT female			<b>EP</b> EPDM seals -45°C to +120°C	
	<b>/75P</b> 3/4" BSPP female			<b>KLZ</b> Kalrez® seals -25°C to +120°C	
	<b>/75N</b> 3/4" NPT female			<b>HNBR</b> Hydrogenated Nitrile seals -20°C to +120°C	

G option must be selected  
Leave blank if not required  
Leave blank for Viton® seals -10°C to +120°C  
Further seal options are available on request  
⚠ Exposure to high and low fluid temperatures will influence handle temperature. Operator safety must be considered.

Repair and seal kits are available on request  
For a seal kit add SK at the end of the model code and for a repair kit add RK



Catalogue also available on digital media  
Visit our website for a full online search facility  
[www.bisvalves.co.uk](http://www.bisvalves.co.uk)



**BS VALVES**  
The Specifier's Catalogue

SOLENOID  
FLOW CONTROL  
3 PORT DIRECTIONAL CONTROL  
4 PORT DIRECTIONAL CONTROL  
CHECK AND SHUTTLE  
PILOT OPERATED CHECK  
RELIEF  
EXCESS FLOW  
FILTERS  
PRESSURE SENSING  
PUMPS  
ACTUATORS  
TECHNICAL DATA

# BNV44AE

## STOP VALVE

1/4"

UP TO 1379 BAR  
20,000 PSI

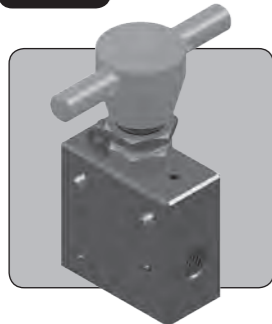

The BNV44AE is a 1/4" OD tube medium pressure ported stop valve. It provides tight shut-off when closed via the T-bar handle.

The elastomeric stem seal design allows long term use without the need to adjust seal packings in service. Combined with a minimised backlash design, the valve is particularly

suitable to pressure testing and other applications where reliable operation is essential.

- Manual stop or shut-off valve
- Suitable for uni-directional or bi-directional shut-off
- Industry standard port and mounting configurations
- Non-rotating valve stem protects valve seat
- Free running, anti-galling handle assembly
- Minimised backlash provides greater operator control
- Metal to metal seating with hardened stem for durability
- Panel mountable and lockable adjustment
- Suitable for use with mineral oils, water glycols and plain water
- Compatible with many other media, contact us for advice
- All wetted parts comply with NACE MR01-75

### Specifications

**BASIC MODEL NUMBER**

**BNV44AE**

**SYMBOL**

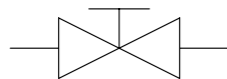

**MAX WORKING PRESSURE**

1,379 bar  
(20,000 psi)

**CV (FLOW CAPACITY)**

Up to 0.19  
See performance graph

**FLUID**

Liquids only  
See materials section

**TEMPERATURE RANGE**

See Product Selector opposite  
and Technical Data section

**PORT SIZE**

1/4" OD medium pressure

**WEIGHT**

0.7 kg  
(1.5 lb)

Specifications may change without notice

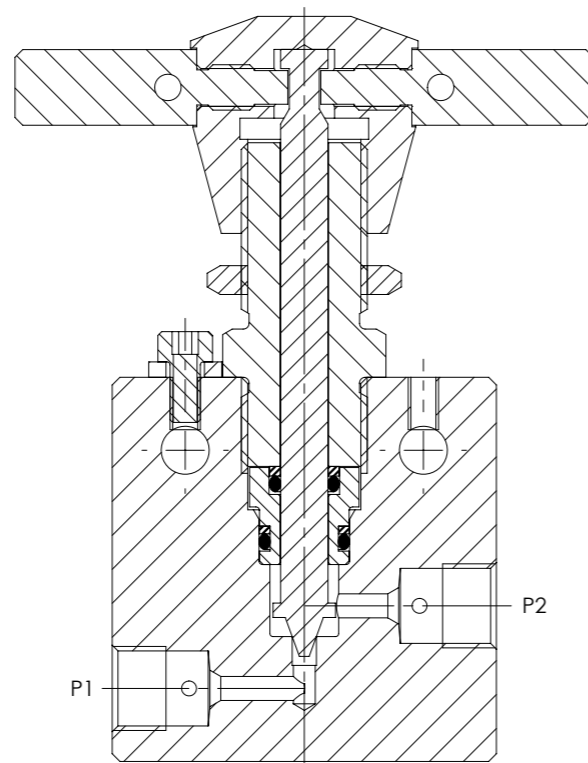

### Materials

Externally Exposed Parts: 316, other 300 series stainless steels and aluminium bronze.

Internally Wetted Parts: 316 and 17-4 PH stainless steel, and acetal.

The standard valve is designed for use with mineral oil, water glycols and plain water, but may be used with a wide variety of media compatible with the materials of construction. Other material options are available, please contact us for advice.

⚠ The standard valve has Viton® seals. Further seal options are available via the Product Selector. Compatibility with the working fluid at the operating temperature must be considered.

### Typical Performance

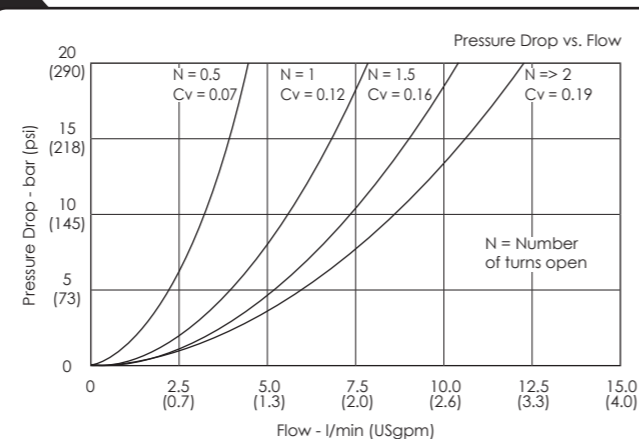

Typical performance based on water

### Installation Diagram

PORTING PATTERN - 01

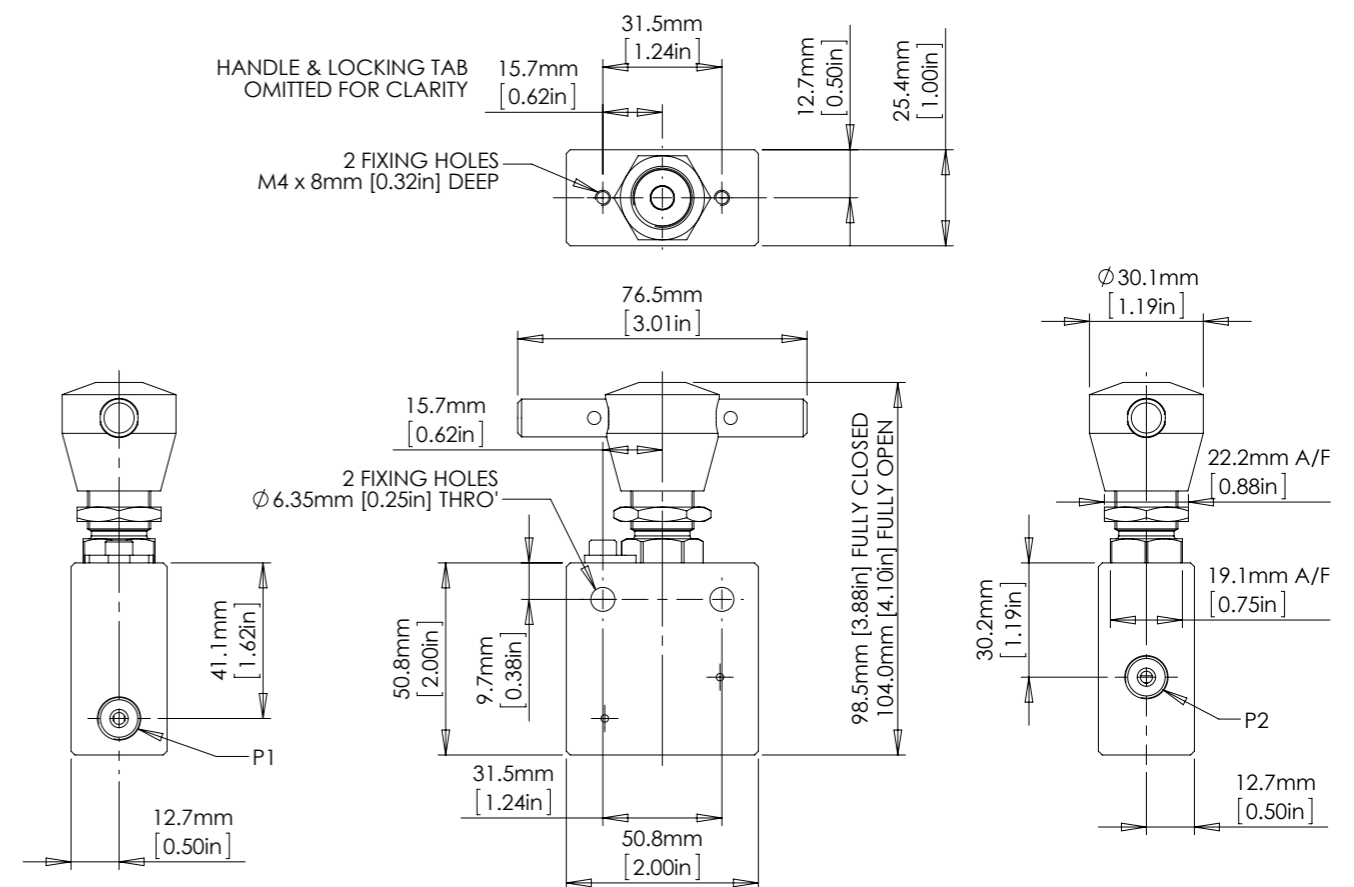

### Product Selector

BNV44AE - 01 - NBR - 20K

VALVE TYPE	PORTING PATTERN	SEAL OPTIONS	MAX WORKING PRESSURE
<b>BNV44AE</b>	<b>01</b> 2-way straight <b>02</b> 2-way angle <b>03</b> 3-way (2 inlets) <b>04</b> 3-way (2 outlets) <b>05</b> 3-way, 2 stem, block-and-bleed	Leave blank for Viton® seals -10°C to +120°C <b>NBR</b> Nitrile seals -30°C to +105°C <b>EP</b> EPDM seals -45°C to +120°C <b>KLZ</b> Kalrez® seals -25°C to +120°C <b>HNBR</b> Hydrogenated Nitrile seals -20°C to +120°C Further seal options are available on request ⚠ Exposure to high and low fluid temperatures will influence handle temperature. Operator safety must be considered.	<b>20K</b> 1,379 bar (20,000 psi) Liquid

Repair and seal kits are available on request

For a seal kit add SK at the end of the model code and for a repair kit add RK



Catalogue also available on digital media  
Visit our website for a full online search facility  
[www.bisvalves.co.uk](http://www.bisvalves.co.uk)



**BS VALVES**  
The Specifier's Catalogue

# BNV44AF

## STOP VALVE

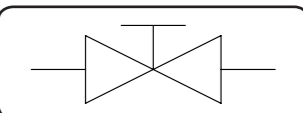

### Porting Pattern 02

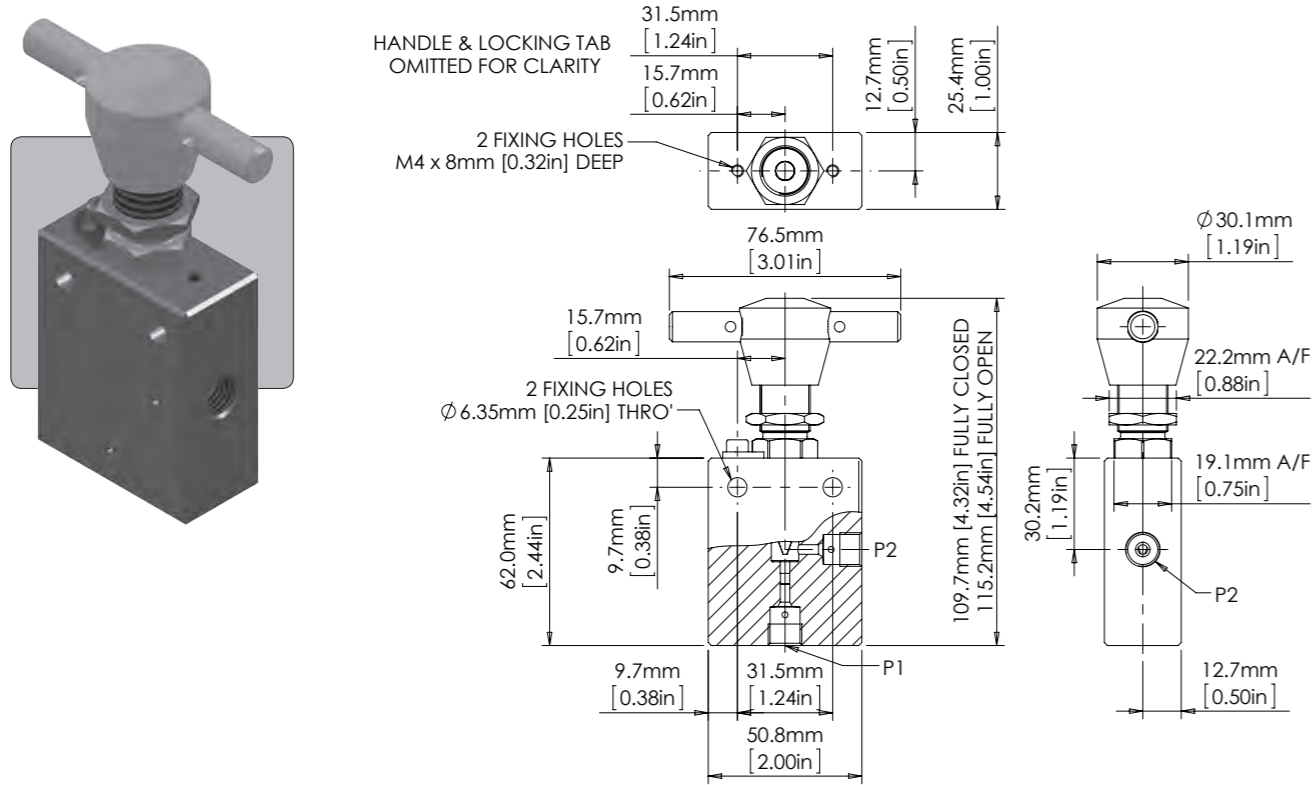

### Porting Pattern 04

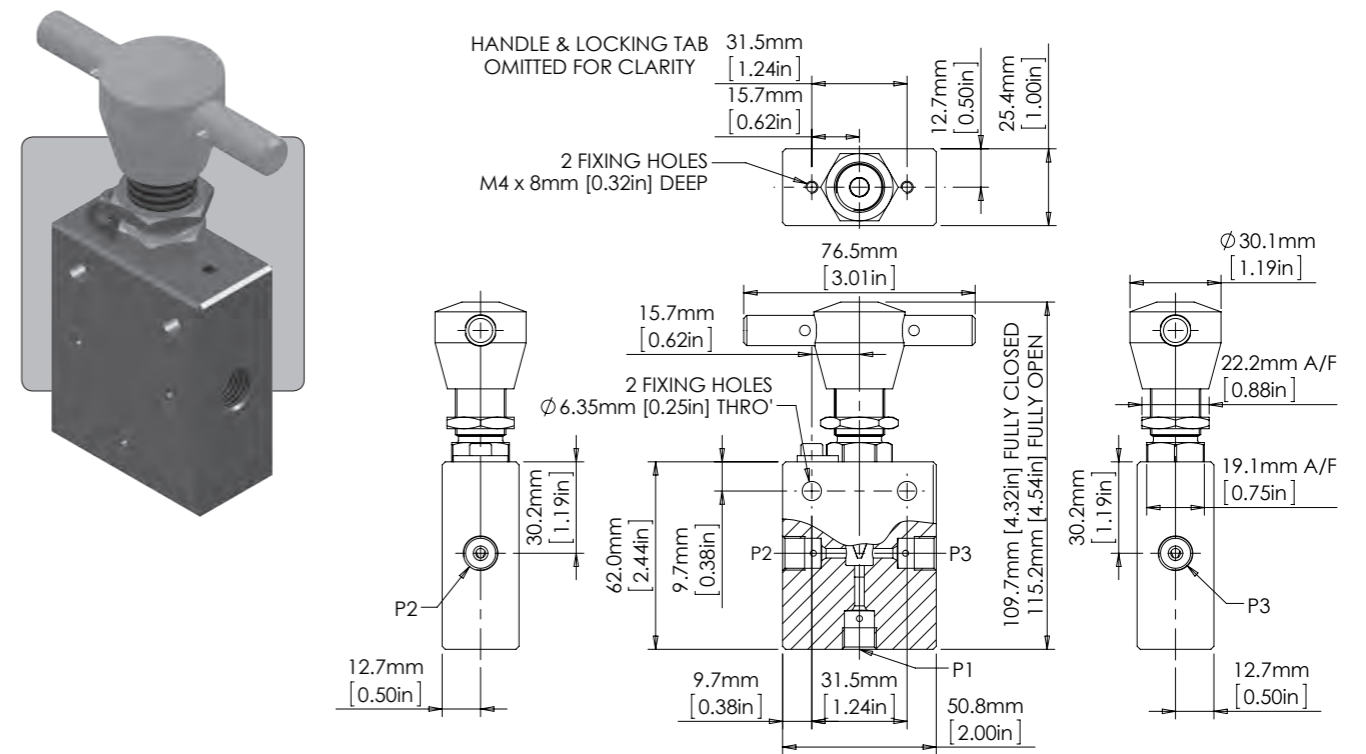

### Porting Pattern 03

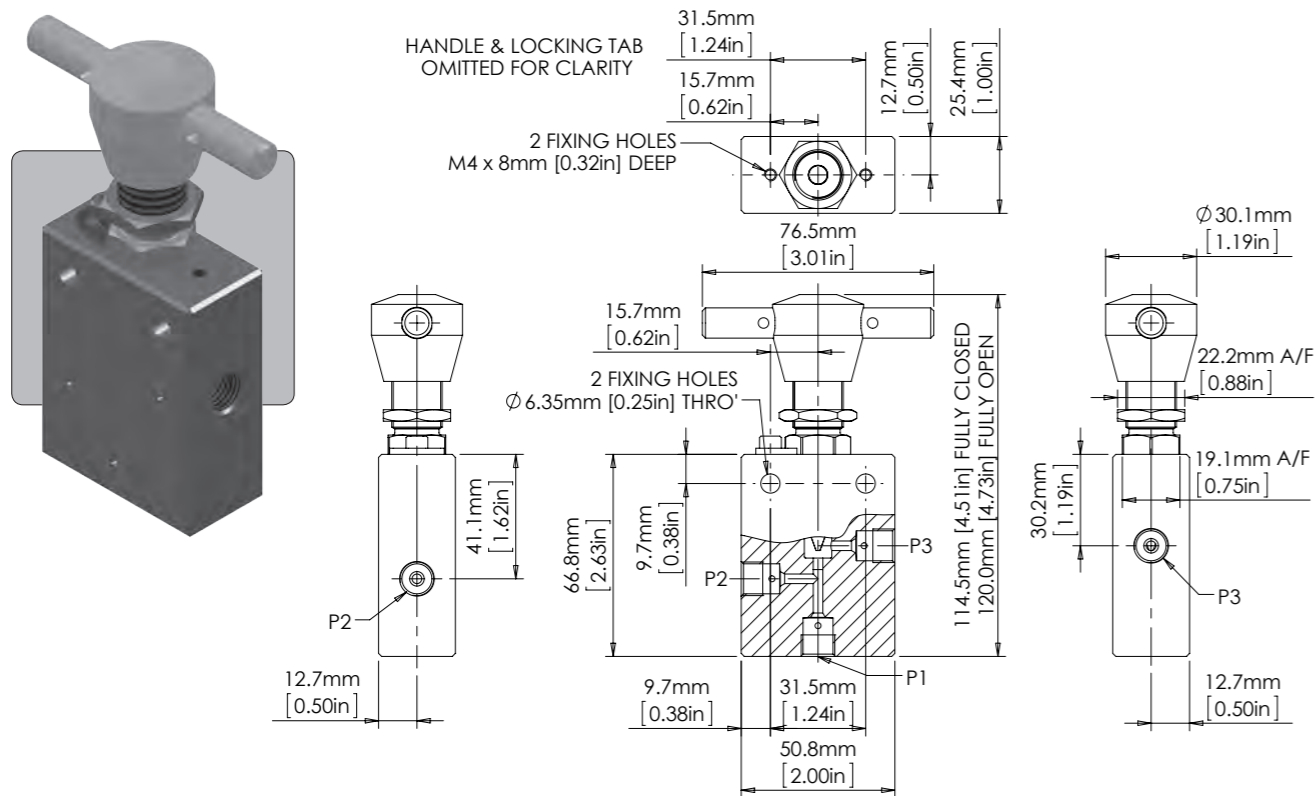

### Porting Pattern 05

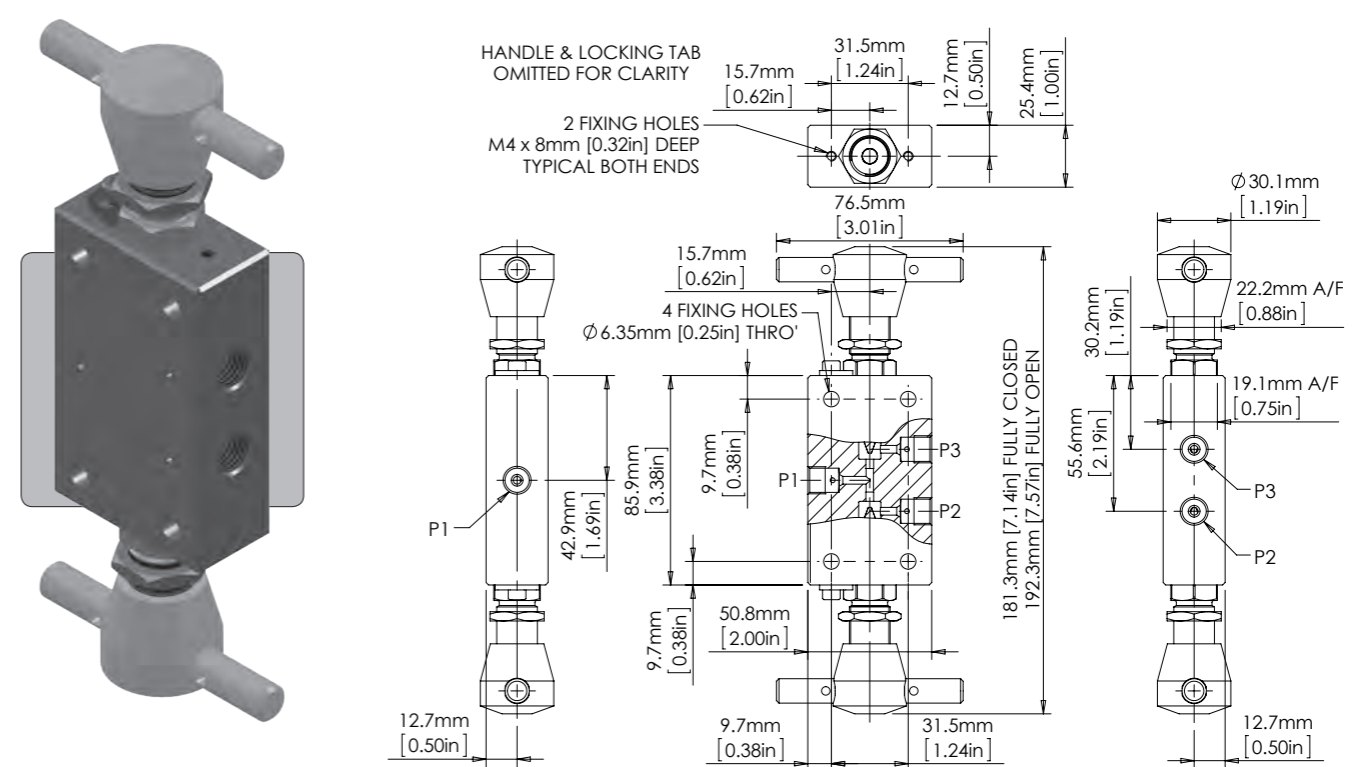

# BNV56AE

## STOP VALVE

3/8"

UP TO 1,379 BAR  
20,000 PSI

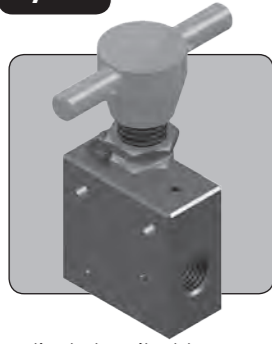

The BNV56AE is a 3/8" OD tube medium pressure ported stop valve. It provides tight shut-off when closed via the T-bar handle.

The elastomeric stem seal design provides long term use without the need to adjust seal packings in service. Combined with a minimised backlash design, the valve is particularly suited to pressure testing and other applications where reliable operation is essential.

- Manual stop or shut-off valve
- Suitable for uni-directional or bi-directional shut-off
- Industry standard port and mounting configurations
- Non-rotating valve stem protects valve seat
- Free running, anti-galling handle assembly
- Minimised backlash provides greater operator control
- Metal to metal seating with hardened stem for durability
- Panel mountable and lockable adjustment
- Suitable for use with mineral oils, water glycols and plain water
- Compatible with many other media, contact us for advice
- All wetted parts comply with NACE MR01-75

### Specifications

<b>BASIC MODEL NUMBER</b>	<b>BNV56AE</b>
<b>SYMBOL</b>	
<b>MAX WORKING PRESSURE</b>	1,379 bar (20,000 psi)
<b>CV (FLOW CAPACITY)</b>	Up to 0.68 <i>See performance graph</i>
<b>FLUID</b>	Liquids only <i>See materials section</i>
<b>TEMPERATURE RANGE</b>	<i>See Product Selector opposite and Technical Data section</i>
<b>PORT SIZE</b>	3/8" OD medium pressure
<b>WEIGHT</b>	0.7 kg (1.5 lb)

Specifications may change without notice

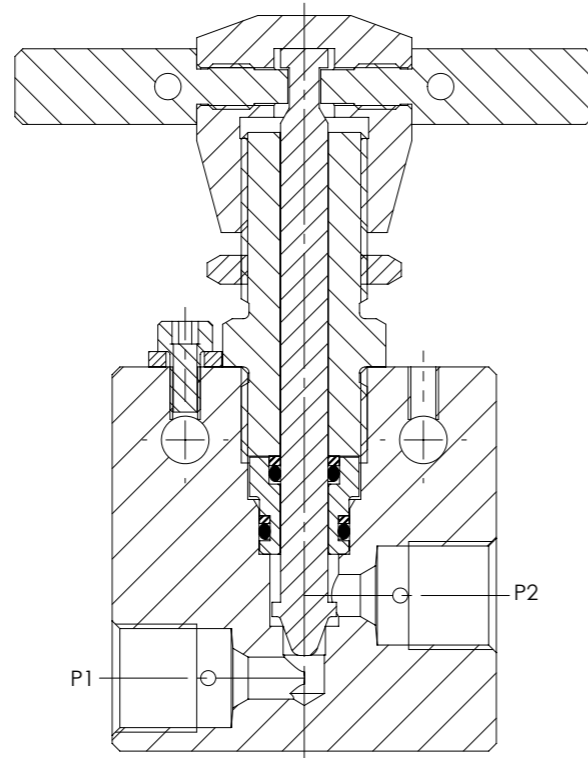

### Materials

Externally Exposed Parts: 316, other 300 series stainless steels and aluminium bronze.

Internally Wetted Parts: 316 and 17-4 PH stainless steel and acetal.

The standard valve is designed for use with mineral oil, water glycols and plain water, but may be used with a wide variety of media compatible with the materials of construction. Other material options are available, please contact us for advice.

**!** The standard valve has Viton® seals. Further seal options are available via the Product Selector. Compatibility with the working fluid at the operating temperature must be considered.

### Typical Performance

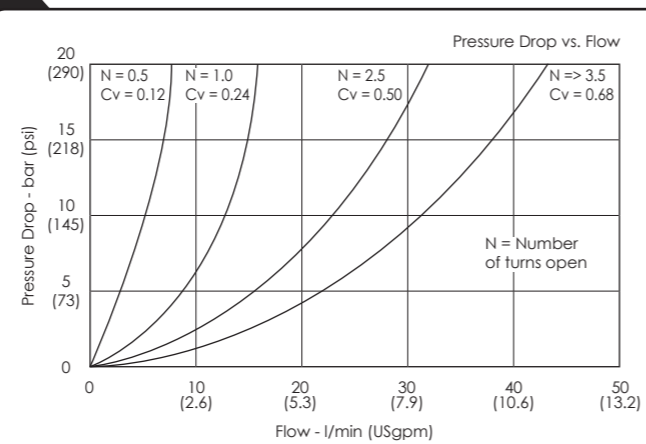

Typical performance based on water

### Installation Diagram

#### PORTING PATTERN - 01

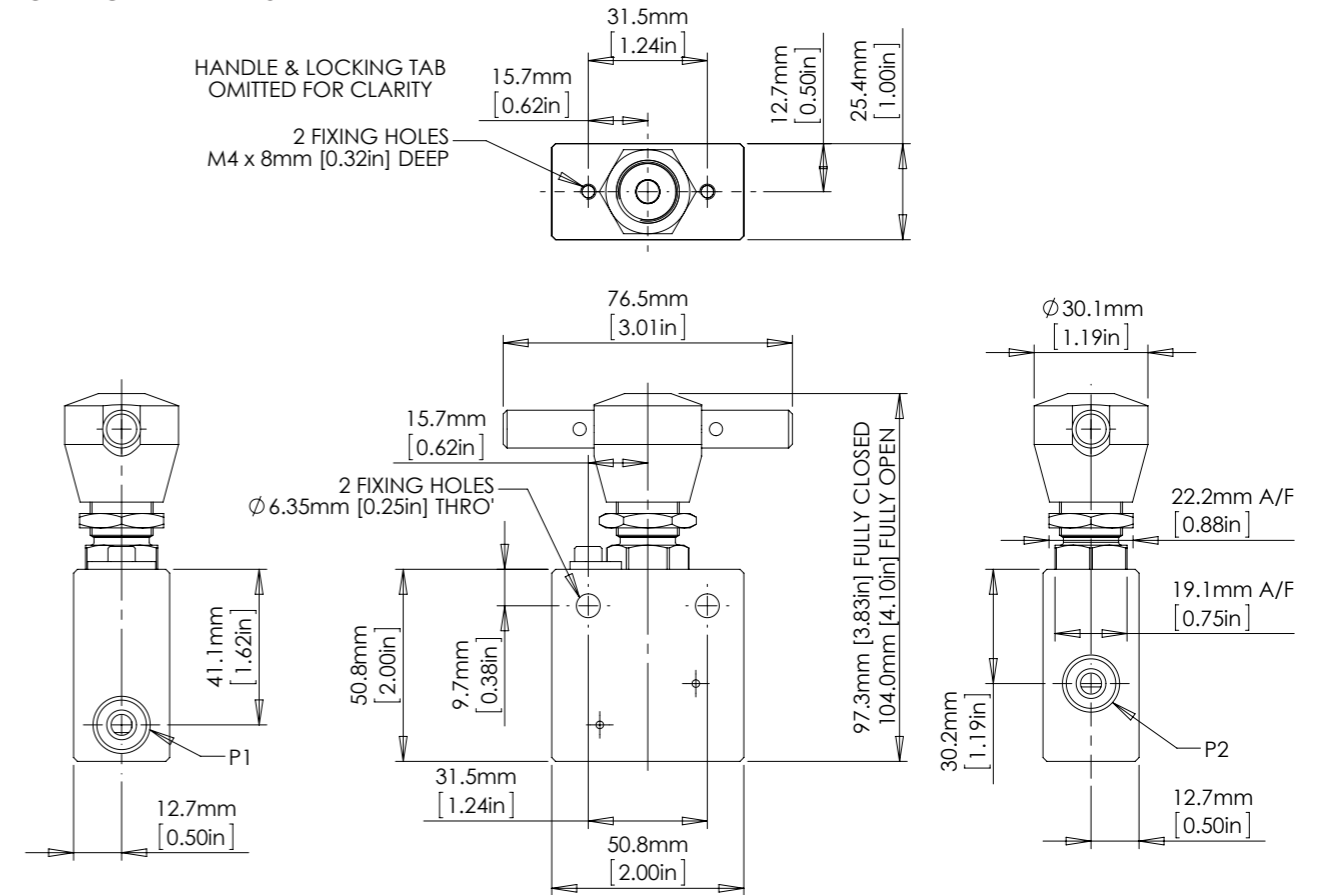

### Product Selector

#### BNV56AE - 01 - NBR - 20K

VALVE TYPE	PORTING PATTERN	SEAL OPTIONS	MAX WORKING PRESSURE
<b>BNV56AE</b>	<b>01</b> 2-way straight <b>02</b> 2-way angle <b>03</b> 3-way (2 inlets) <b>04</b> 3-way (2 outlets) <b>05</b> 3-way, 2 stem, block-and-bleed	Leave blank for Viton® seals -10°C to +120°C <b>NBR</b> Nitrile seals -30°C to +105°C <b>EP</b> EPDM seals -45°C to +120°C <b>KLZ</b> Kalrez® seals -25°C to +120°C <b>HNBR</b> Hydrogenated Nitrile seals -20°C to +120°C Further seal options are available on request Exposure to high and low fluid temperatures will influence handle temperature. Operator safety must be considered.	<b>20K</b> 1,379 bar (20,000 psi) Liquid

Repair and seal kits are available on request

For a seal kit add SK at the end of the model code and for a repair kit add RK



Catalogue also available on digital media  
Visit our website for a full online search facility  
[www.bisvalves.co.uk](http://www.bisvalves.co.uk)

**BS VALVES**  
The Specifier's Catalogue

SOLENOID  
FLOW CONTROL  
3 PORT DIRECTIONAL CONTROL  
4 PORT DIRECTIONAL CONTROL  
CHECK AND SHUTTLE  
PILOT OPERATED CHECK  
RELIEF  
EXCESS FLOW  
FILTERS  
PRESSURE SENSING  
PUMPS  
ACTUATORS  
TECHNICAL DATA



# BNV56AF

## STOP VALVE

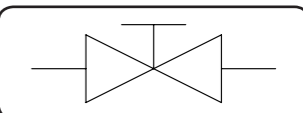

### Porting Pattern 02

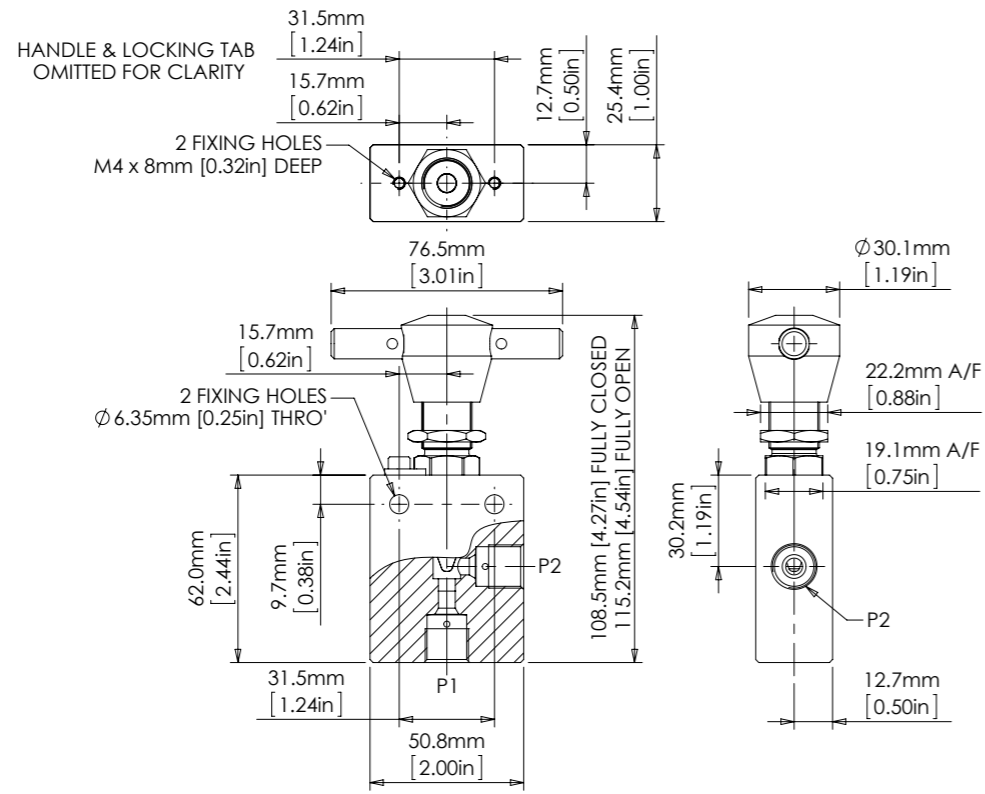
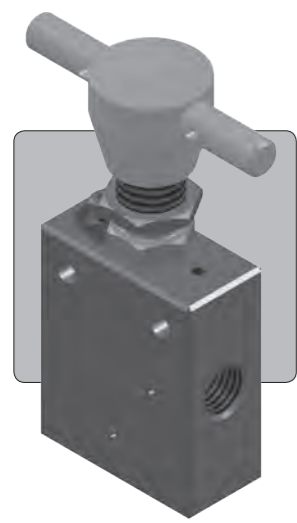

### Porting Pattern 04

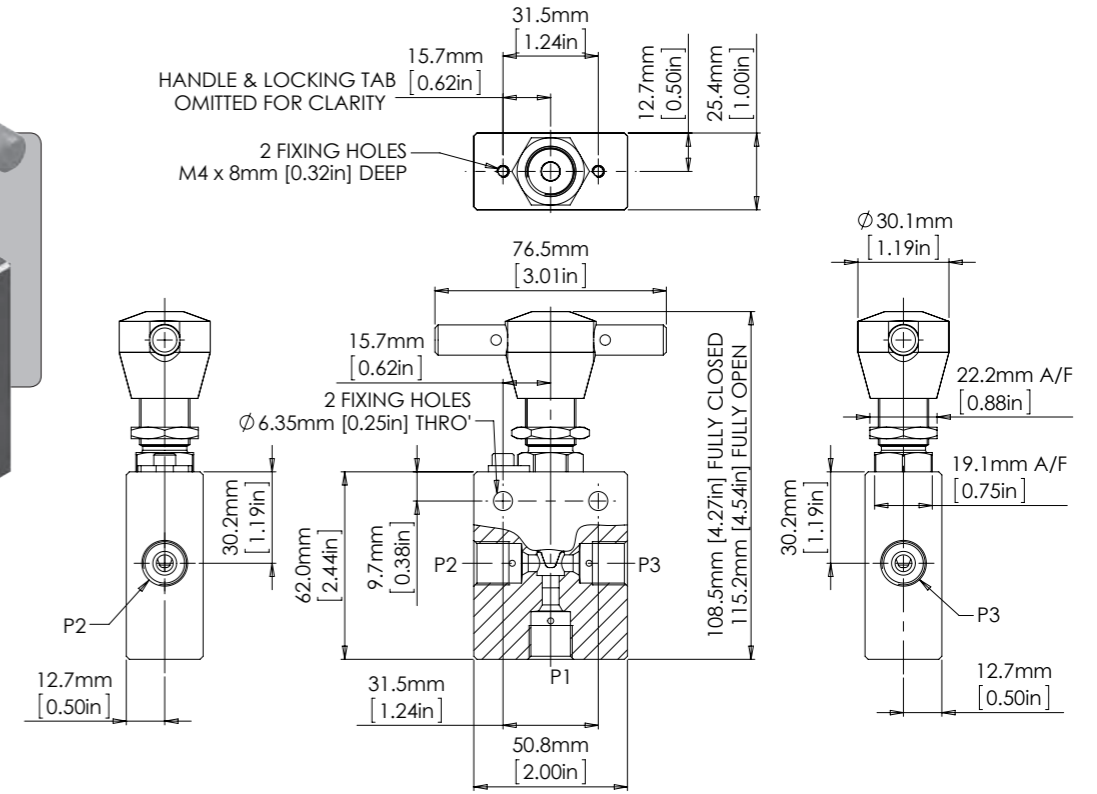

### Porting Pattern 03

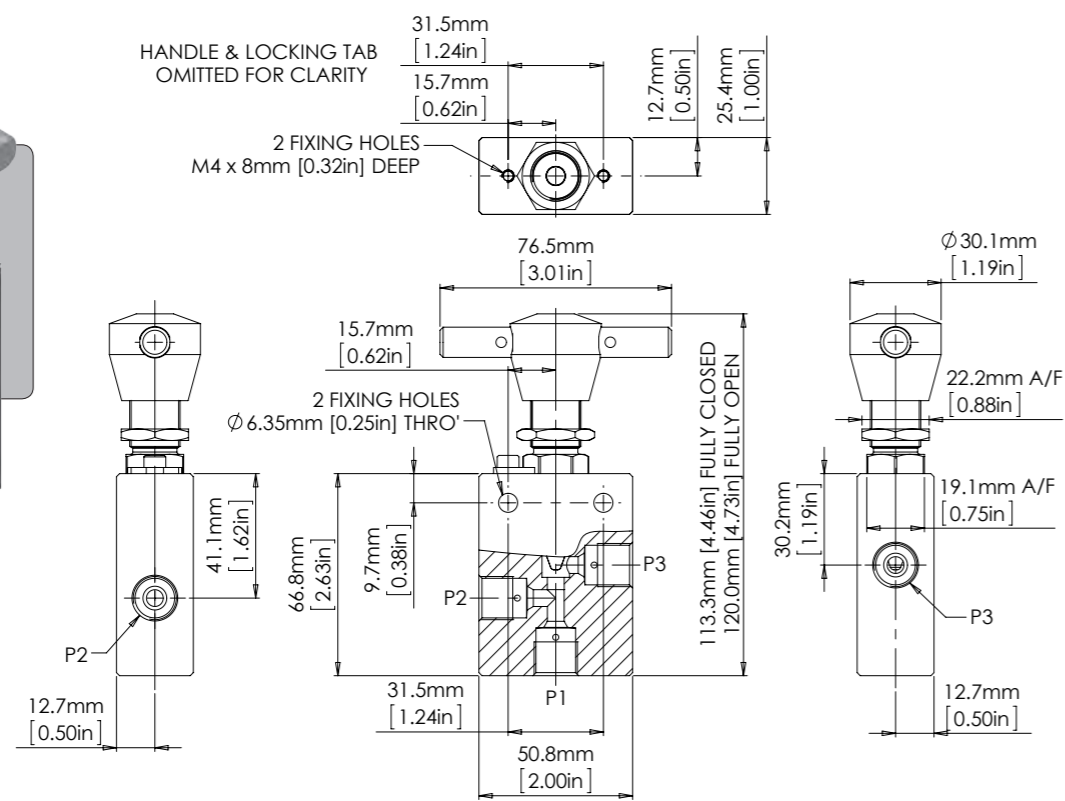

### Porting Pattern 05

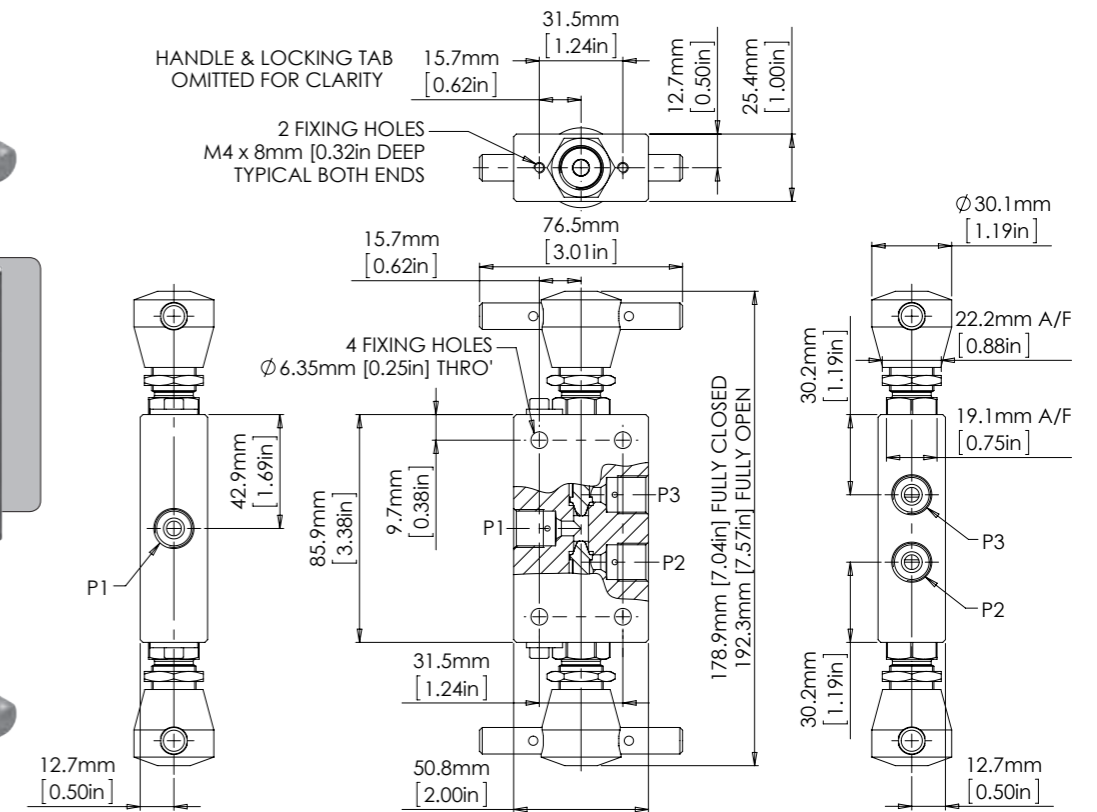
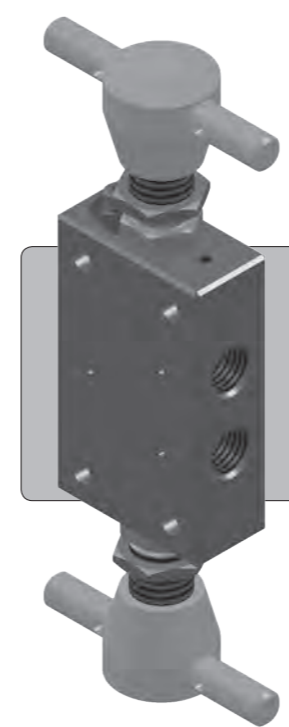

- SOLENOID
- FLOW CONTROL
- 3 PORT DIRECTIONAL CONTROL
- 4 PORT DIRECTIONAL CONTROL
- CHECK AND SHUTTLE
- PILOT OPERATED CHECK
- RELIEF
- EXCESS FLOW
- FILTERS
- PRESSURE SENSING
- PUMPS
- ACTUATORS
- TECHNICAL DATA

# BNV81AE

## STOP VALVE

9/16"

UP TO 1,379 BAR  
20,000 PSI

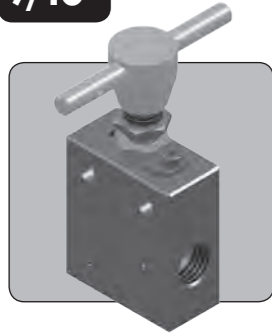

The BNV81AE is a 9/16" OD tube medium pressure ported stop valve. It provides tight shut-off when closed via the T-bar handle.

The elastomeric stem seal design provides long term use without the need to adjust seal packings in service. Combined with a minimised backlash design, the valve is particularly suited to pressure testing and other applications where reliable operation is essential.

particularly suited to pressure testing and other applications where reliable operation is essential.

- Manual stop or shut-off valve
- Suitable for uni-directional or bi-directional shut-off
- Industry standard port and mounting configurations
- Non-rotating valve stem protects valve seat
- Free running, anti-galling handle assembly
- Minimised backlash provides greater operator control
- Metal to metal seating with hardened stem for durability
- Panel mountable and lockable adjustment
- Suitable for use with mineral oils, water glycols and plain water
- Compatible with many other media, contact us for advice
- All wetted parts comply with NACE MR01-75

### Specifications

**BASIC MODEL NUMBER**

**BNV81AE**

**SYMBOL**

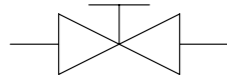

**MAX WORKING PRESSURE**

1,379 bar  
(20,000 psi)

**CV (FLOW CAPACITY)**

Up to 1.45  
See performance graph

**FLUID**

Liquids only  
See materials section

**TEMPERATURE RANGE**

See Product Selector opposite  
and Technical Data section

**PORT SIZE**

9/16" OD medium pressure

**WEIGHT**

1.27 kg  
(2.80 lb)

Specifications may change without notice

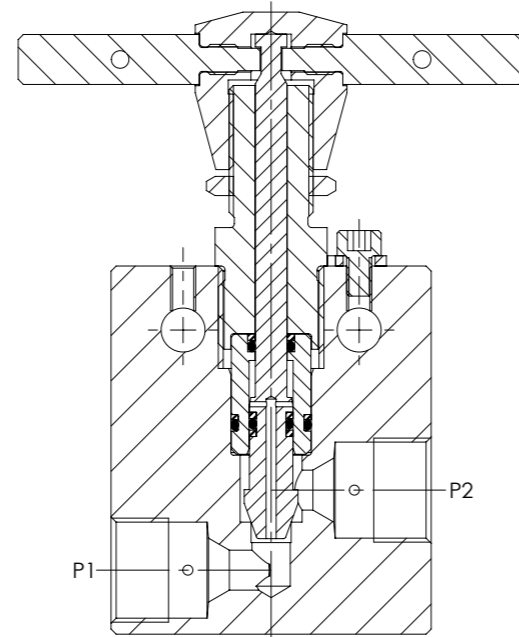

### Materials

Externally Exposed Parts: 316, other 300 series stainless steels and aluminium bronze.

Internally Wetted Parts: 316 and 17-4 PH stainless steel and acetal.

The standard valve is designed for use with mineral oil, water glycols and plain water, but may be used with a wide variety of media compatible with the materials of construction. Other material options are available, please contact us for advice.

⚠ The standard valve has Viton® seals. Further seal options are available via the Product Selector. Compatibility with the working fluid at the operating temperature must be considered.

### Typical Performance

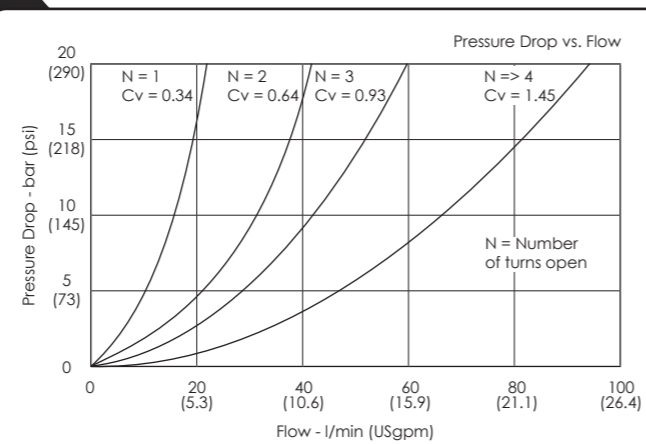

Typical performance based on water

### Installation Diagram

#### PORTING PATTERN - 01

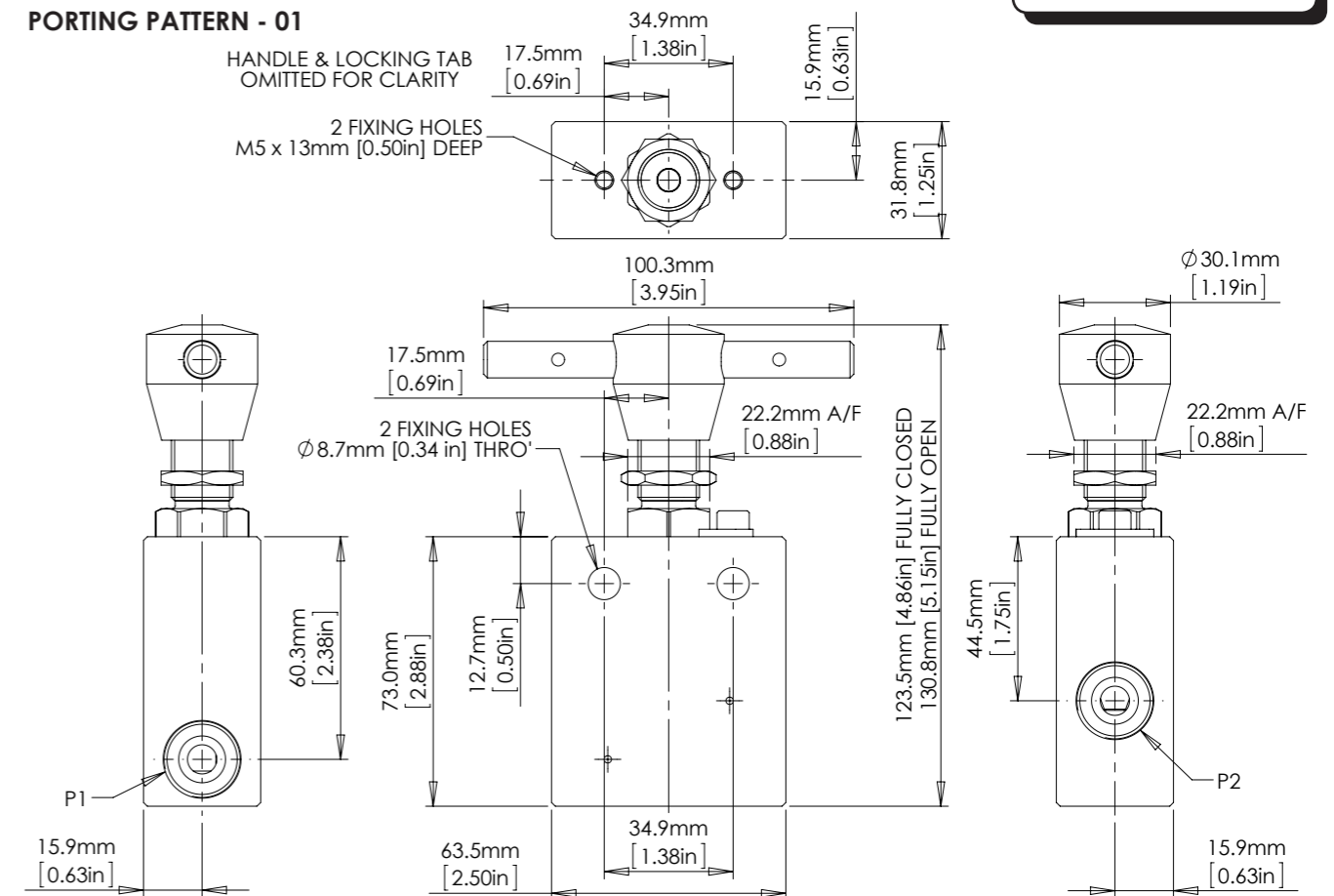

### Product Selector

#### BNV81AE - 01 - NBR - 20K

VALVE TYPE	PORTING PATTERN	SEAL OPTIONS	MAX WORKING PRESSURE
<b>BNV81AE</b>	<b>01</b> 2-way straight <b>02</b> 2-way angle <b>03</b> 3-way (2 inlets) <b>04</b> 3-way (2 outlets) <b>05</b> 3-way, 2 stem, block-and-bleed	Leave blank for Viton® seals -10°C to +120°C <b>NBR</b> Nitrile seals -30°C to +105°C <b>EP</b> EPDM seals -45°C to +120°C <b>KLZ</b> Kalrez® seals -25°C to +120°C <b>HNBR</b> Hydrogenated Nitrile seals -20°C to +120°C Further seal options are available on request ⚠ Exposure to high and low fluid temperatures will influence handle temperature. Operator safety must be considered.	<b>20K</b> 1,379 bar (20,000 psi) Liquid

Repair and seal kits are available on request

For a seal kit add SK at the end of the model code and for a repair kit add RK



Catalogue also available on digital media  
Visit our website for a full online search facility  
[www.bisvalves.co.uk](http://www.bisvalves.co.uk)



**BS VALVES**  
The Specifier's Catalogue

SOLENOID  
FLOW CONTROL  
3 PORT DIRECTIONAL CONTROL  
4 PORT DIRECTIONAL CONTROL  
CHECK AND SHUTTLE  
PILOT OPERATED CHECK  
RELIEF  
EXCESS FLOW  
FILTERS  
PRESSURE SENSING  
PUMPS  
ACTUATORS  
TECHNICAL DATA

# BNV81AF

## STOP VALVE

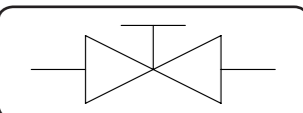

### Porting Pattern 02

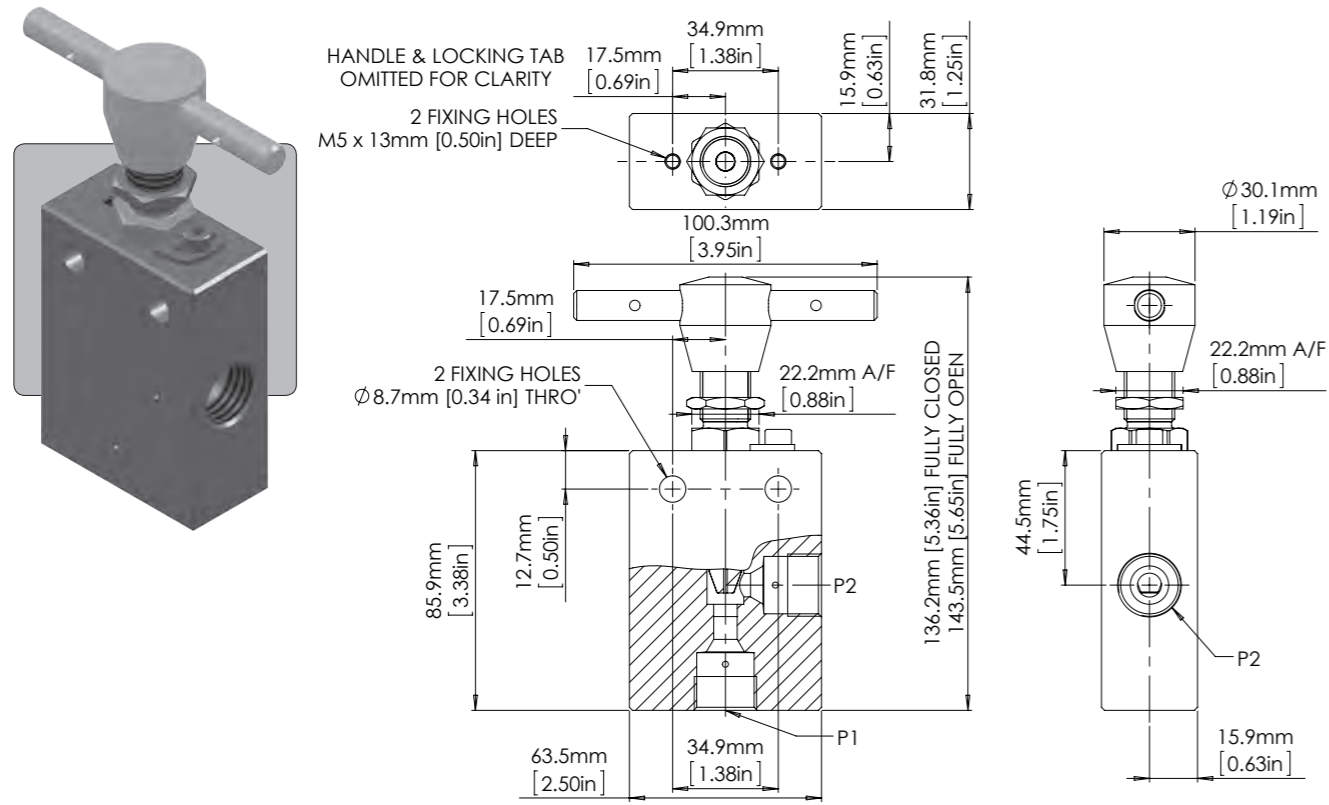

### Porting Pattern 04

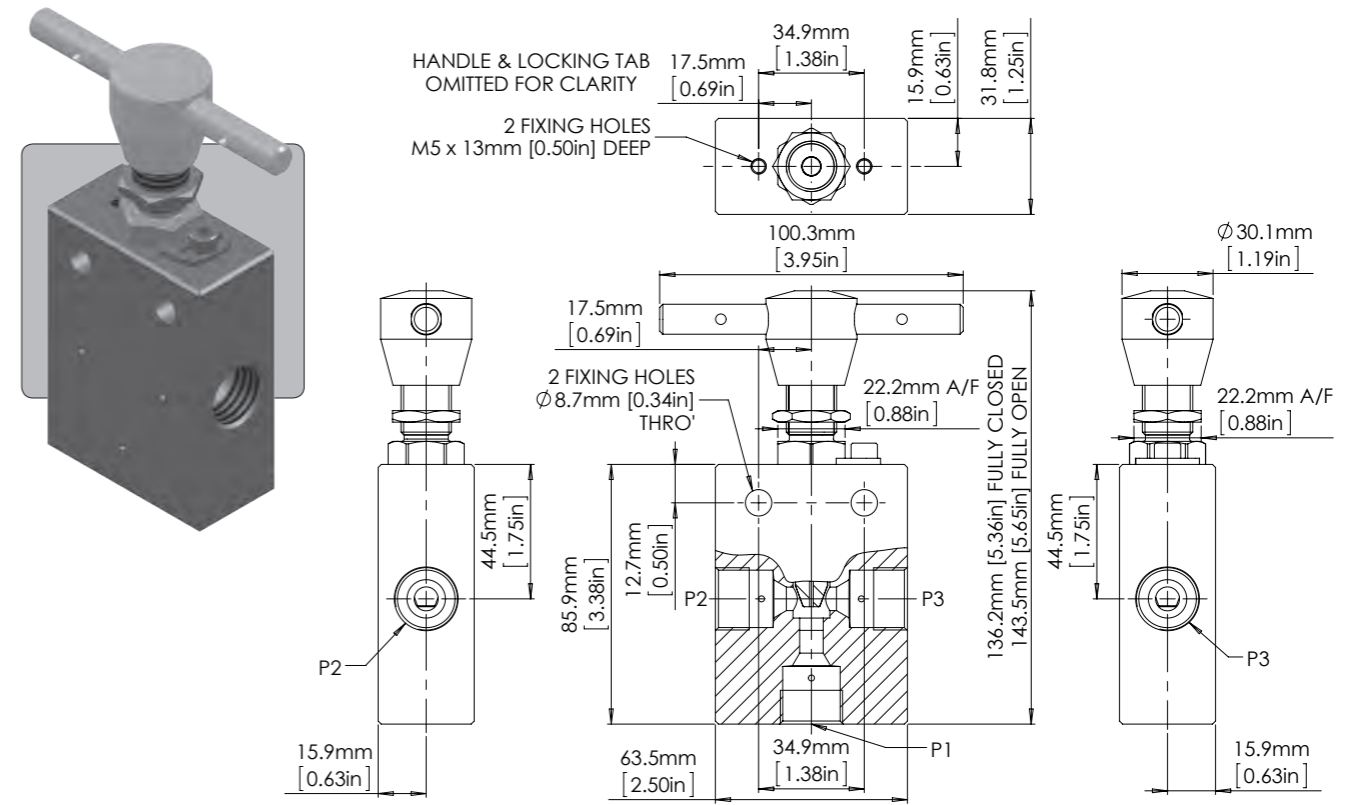

### Porting Pattern 03

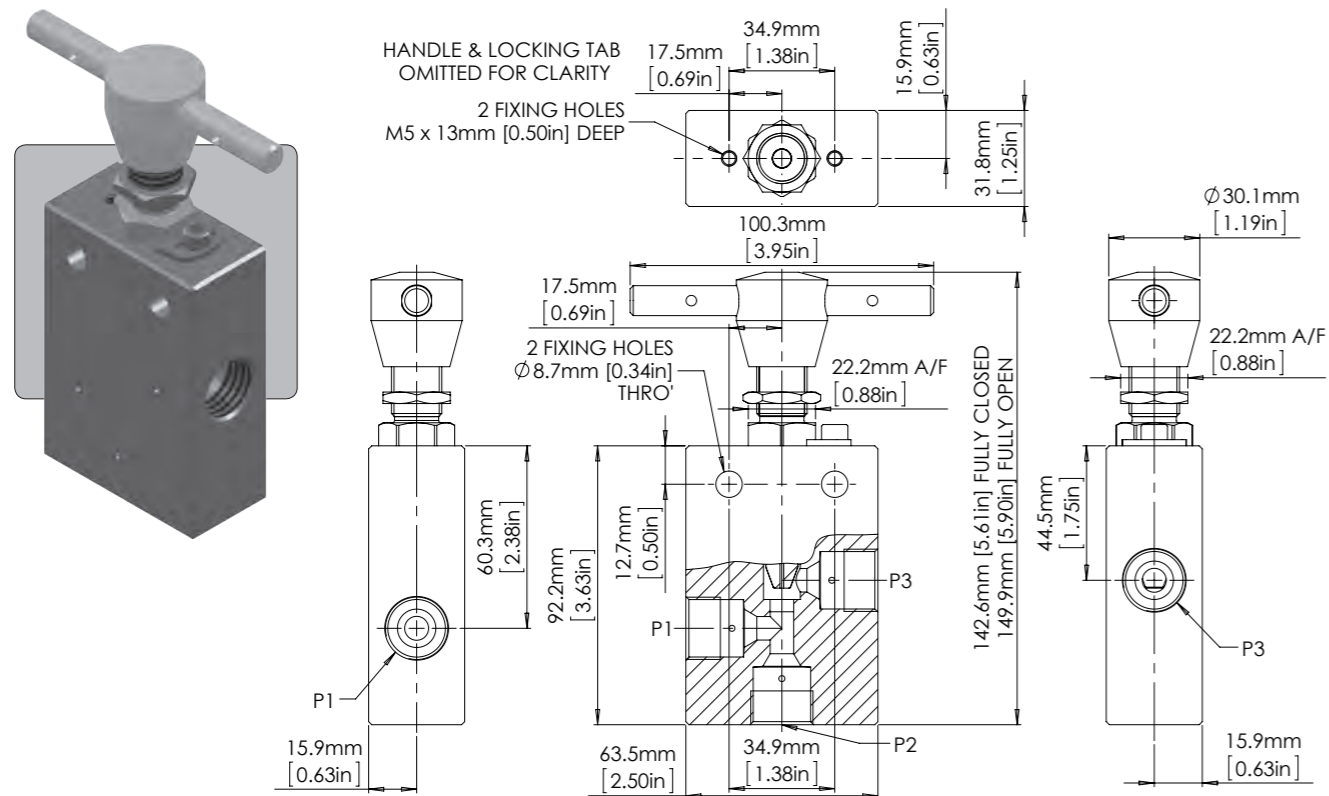

### Porting Pattern 05

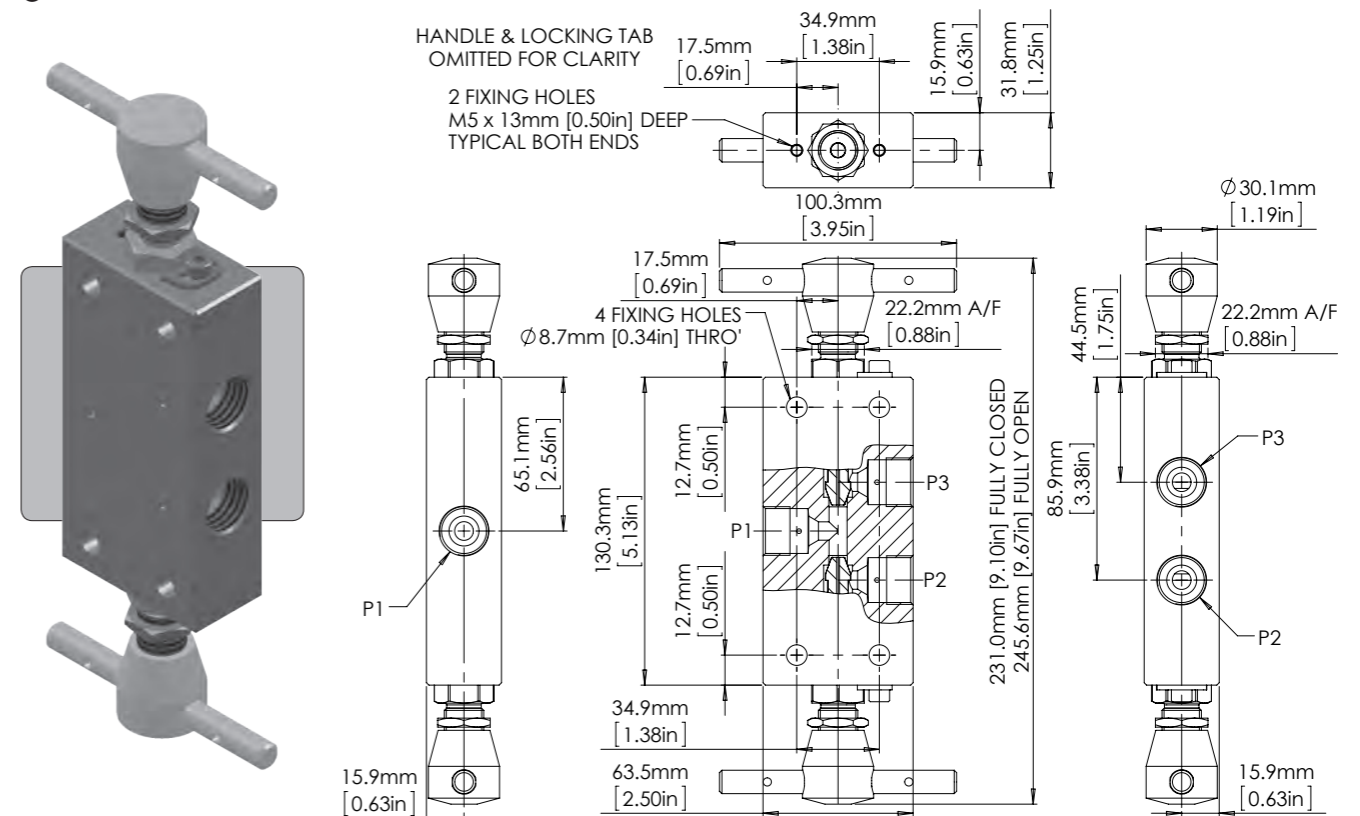

# MF25 METERING VALVE

**1/4" UP TO 552 BAR 8,000 PSI**

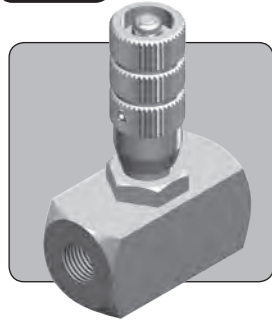

The MF25 is a 1/4" nominal bore flow metering valve, adjustable via a micrometer style handle. The valve is marked with a preferred direction of flow, but it may be used in the opposite direction to provide bi-directional speed control of a cylinder or actuator, although the level of metering will vary depending on direction.

Note that this valve is not intended to provide tight shut-off when closed.

- Flow control valve for metering applications
- Micrometer style adjustment with engraved graduations
- Lockable adjustment
- Non-rotating valve stem protects valve seat
- Suitable for short term subsea use
- Suitable for liquid or gas
- Suitable for use with air, nitrogen, sweet natural gas, mineral oils, water glycols and plain water
- Suitable for many other media. Contact us for advice
- Cartridge, manifold mount and panel mount versions available
- Various porting and seal options available

## Specifications

**BASIC MODEL NUMBER**

**MF25**

**SYMBOL**

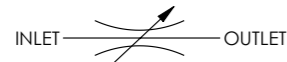

**MAX WORKING PRESSURE (LIQUID)**

552 bar  
(8,000 psi)

**MAX WORKING PRESSURE (GAS)**

276 bar  
(4,000 psi)

**CV (FLOW CAPACITY)**

Up to 0.65  
See Typical Performance Graph

**FLUID**

Liquids and Gases  
See materials section

**TEMPERATURE RANGE**

See Product Selector opposite  
and Technical Data section

**PORT SIZE**

1/4"

**WEIGHT**

0.45 kg  
(1.0 lb)

Specifications may change without notice

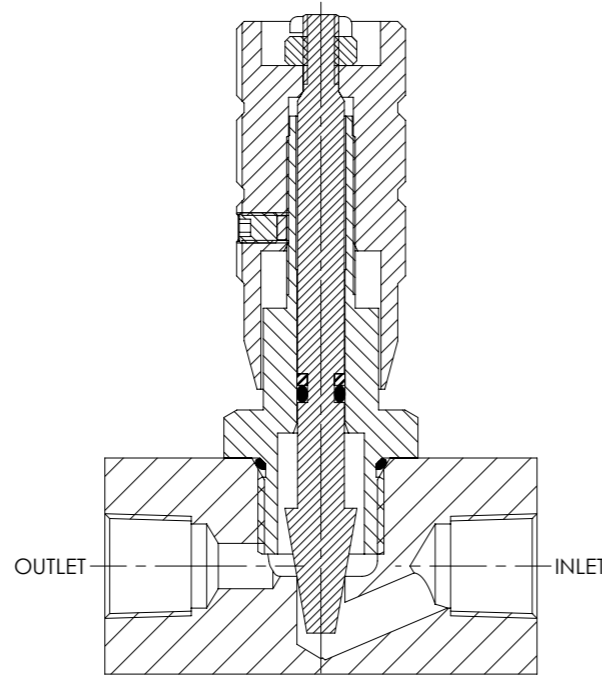

## Materials

Externally Exposed Parts: 316, 304 and 17-4 PH stainless steel.

Internally Wetted Parts: 316 and 17-4 PH stainless steel and PTFE.

The standard valve is designed for use with air, nitrogen, sweet natural gas, mineral oil, water glycols and plain water and may also be used with a wide variety of media compatible with the materials of construction. Other material options are available. Contact us for advice.

⚠ The standard valve has Viton® seals. Further seal options are available via the Product Selector. Compatibility with the working fluid at the operating temperature must be considered.

## Typical Performance

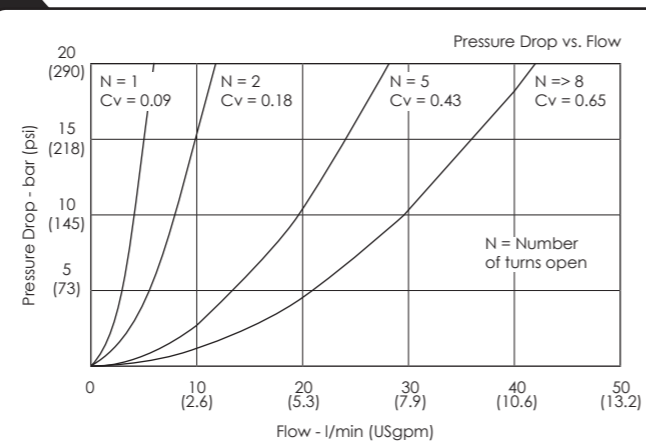

Typical performance based on water

## Installation Diagram

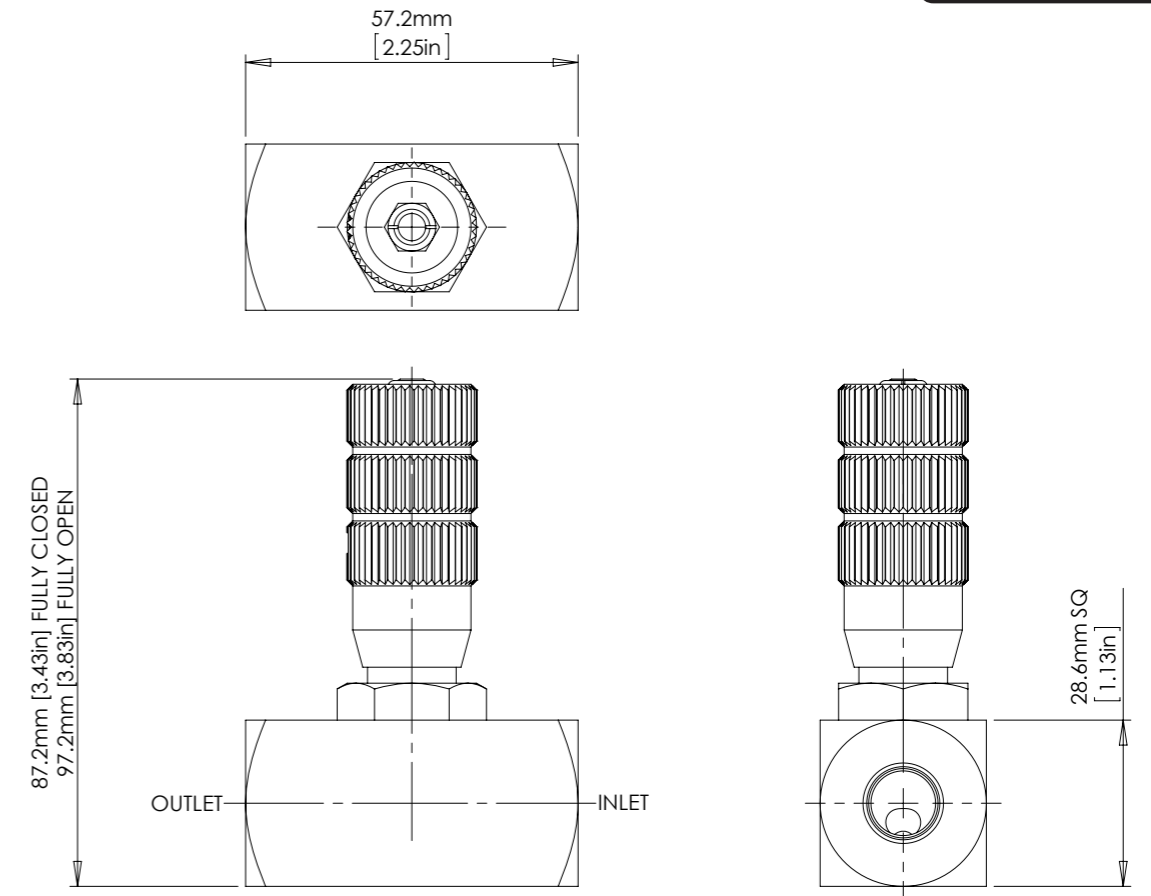

## Product Selector

**MF25 P - PM - NBR - 8K**

VALVE TYPE	PORTING OPTIONS	VALVE OPTIONS	SEAL OPTIONS	MAX WORKING PRESSURE
<b>MF25</b>	<b>P</b> 1/4" BSPP female	<b>PM</b> Panel mount <i>Not available with manifold or cartridge versions</i>	<b>NBR</b> Nitrile seals -30°C to +105°C	<b>8K</b> 552 bar (8,000 psi) Liquid
	<b>N</b> 1/4" NPT female		<b>HNBR</b> Hydrogenated Nitrile seals -20°C to +120°C	276 bar (4,000 psi) Gas
	<b>M</b> Manifold mount		<b>EP</b> EPDM seals -45°C to +120°C	
	<b>C</b> Cartridge style <i>Seat in cavity</i>		<b>KLZ</b> Kalrez seals -25°C to +120°C	
	<b>FC</b> Full cartridge <i>Seat in cartridge</i>			

Repair and seal kits are available on request

For a seal kit add SK at the end of the model code and for a repair kit add RK

Further seal options are available on request

⚠ Exposure to high and low fluid temperatures will influence handle temperature. Operator safety must be considered



Catalogue also available on digital media  
Visit our website for a full online search facility  
[www.bisvalves.co.uk](http://www.bisvalves.co.uk)



**BS VALVES**  
The Specifier's Catalogue

SOLENOID  
FLOW CONTROL  
3 PORT DIRECTIONAL CONTROL  
4 PORT DIRECTIONAL CONTROL  
CHECK AND SHUTTLE  
PILOT OPERATED CHECK  
RELIEF  
EXCESS FLOW  
FILTERS  
PRESSURE SENSING  
PUMPS  
ACTUATORS  
TECHNICAL DATA

# MF25 METERING VALVE

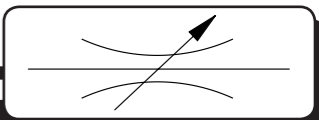

## Cartridge Valve

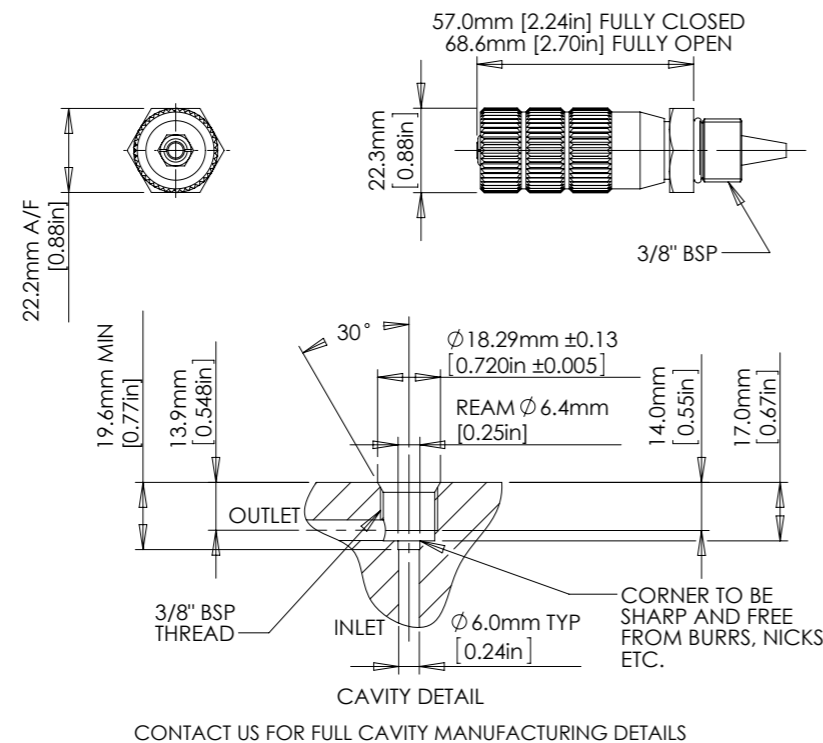
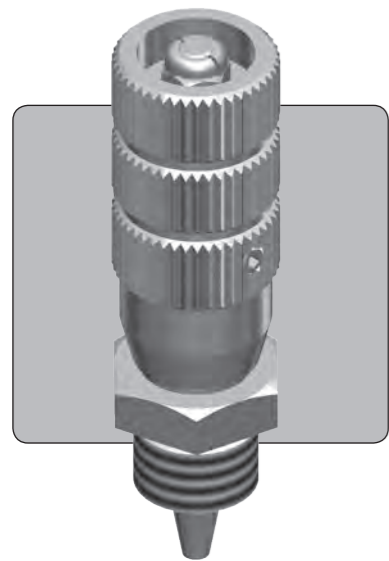

## Panel Mounted Valve

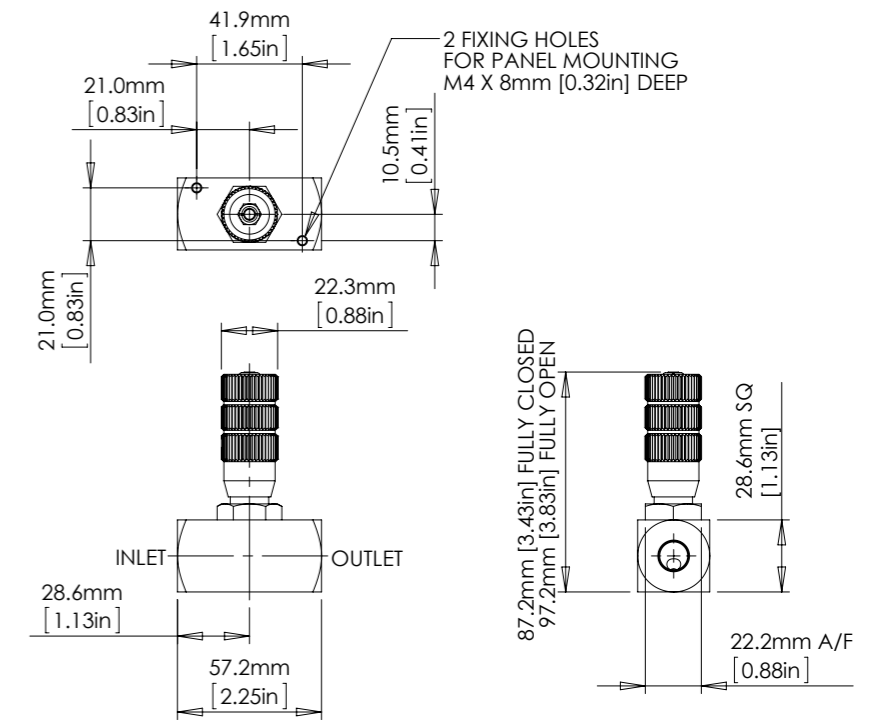
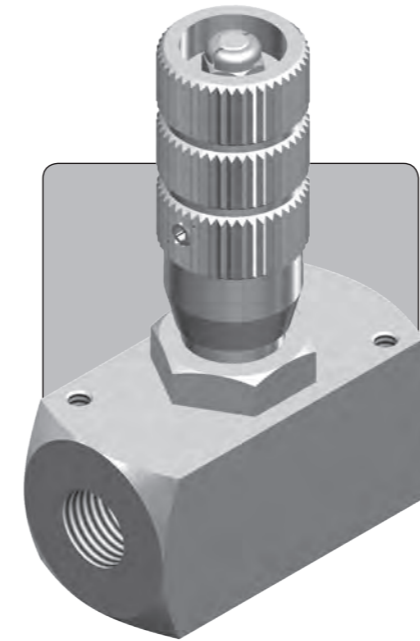

## Full Cartridge Valve

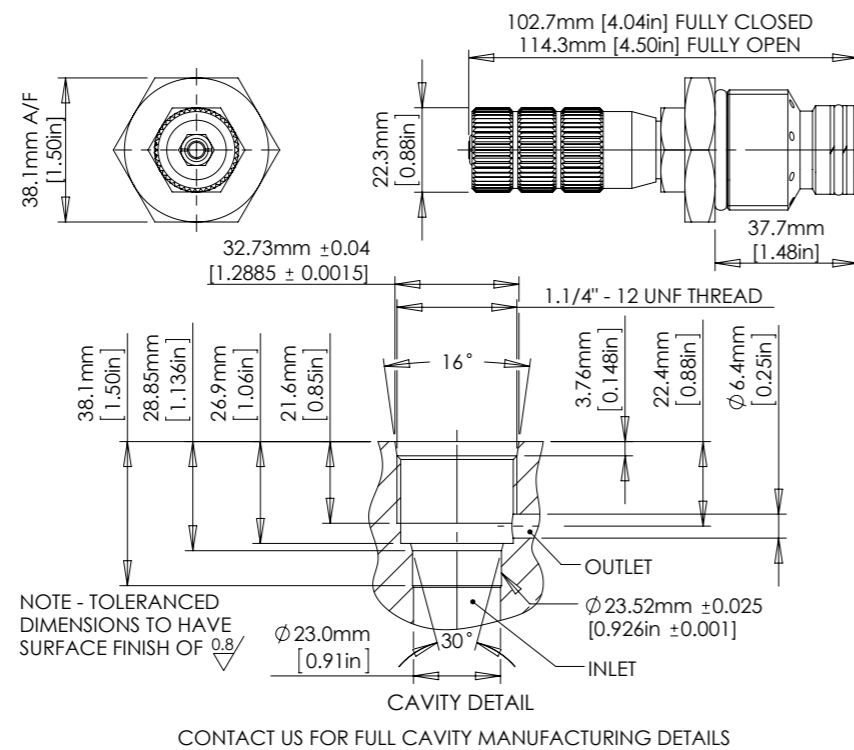
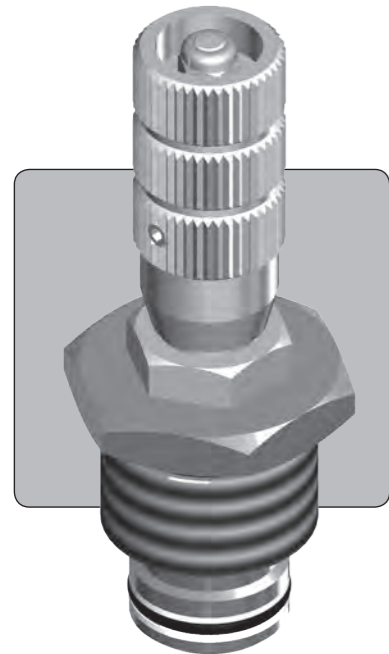

## Manifold Mount Valve

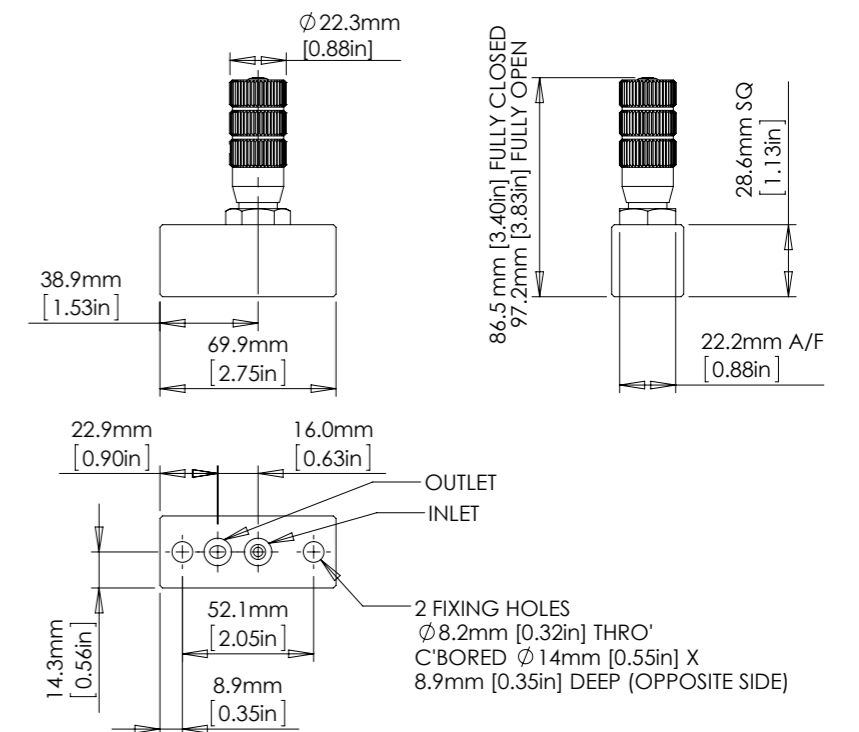
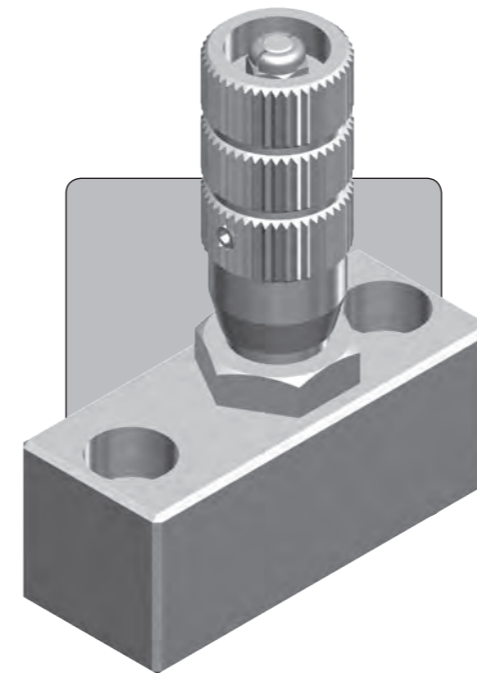

# FMF25

## METERING VALVE

**1/4" UP TO 552 BAR 8,000 PSI**

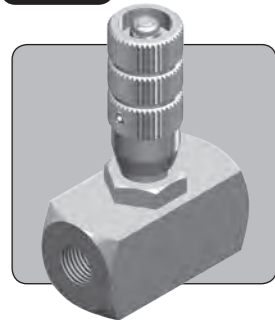

The FMF25 is a 1/4" nominal bore fine flow metering valve, adjustable via a micrometer style handle. The valve is marked with a preferred direction of flow, but it may be used in the opposite direction to provide bi-directional speed control of a cylinder or actuator, although the level of metering will vary depending on direction.

Note that this valve is not intended to provide tight shut-off when closed.

- Fine flow control valve for metering applications
- Micrometer style adjustment with engraved graduations
- Lockable adjustment
- Non-rotating valve stem protects valve seat
- Suitable for short term subsea use
- Suitable for liquid or gas
- Suitable for use with air, nitrogen, sweet natural gas, mineral oils, water glycols and plain water
- Suitable for many other media. Contact us for advice
- Cartridge and manifold mount versions available. Contact us for advice
- Various porting and seal options available

### Specifications

**BASIC MODEL NUMBER**

**FMF25**

**SYMBOL**



**MAX WORKING PRESSURE (LIQUID)**

552 bar  
(8,000 psi)

**MAX WORKING PRESSURE (GAS)**

276 bar  
(4,000 psi)

**CV (FLOW CAPACITY)**

Up to 0.65  
See Typical Performance Graph

**FLUID**

Liquids and Gases  
See materials section

**TEMPERATURE RANGE**

See Product Selector opposite and Technical Data section

**PORT SIZE**

1/4"

**WEIGHT**

0.45 kg  
(1.0lb)

Specifications may change without notice

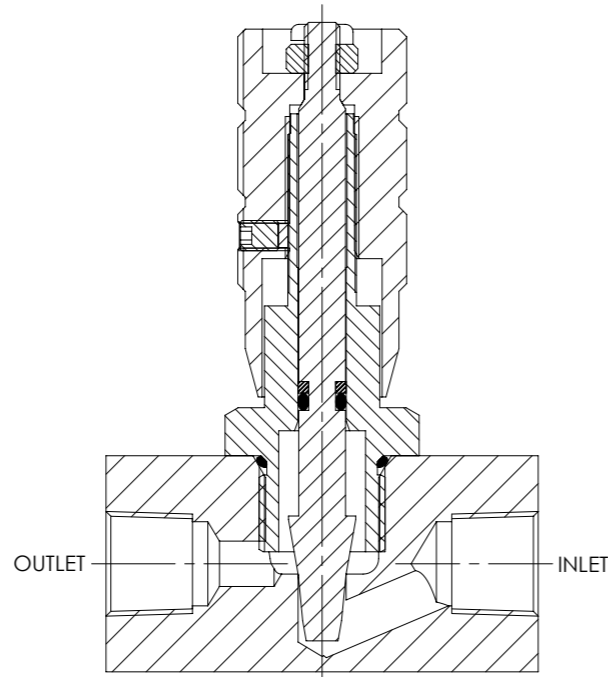

### Materials

Externally Exposed Parts: 316, 304 and 17-4 PH stainless steel.

Internally Wetted Parts: 316 and 17-4 PH stainless steel and PTFE.

The standard valve is designed for use with air, nitrogen, sweet natural gas, mineral oil, water glycols and plain water and may also be used with a wide variety of media compatible with the materials of construction. Other material options are available. Contact us for advice.

⚠ The standard valve has Viton® seals. Further seal options are available via the Product Selector. Compatibility with the working fluid at the operating temperature must be considered.

### Typical Performance

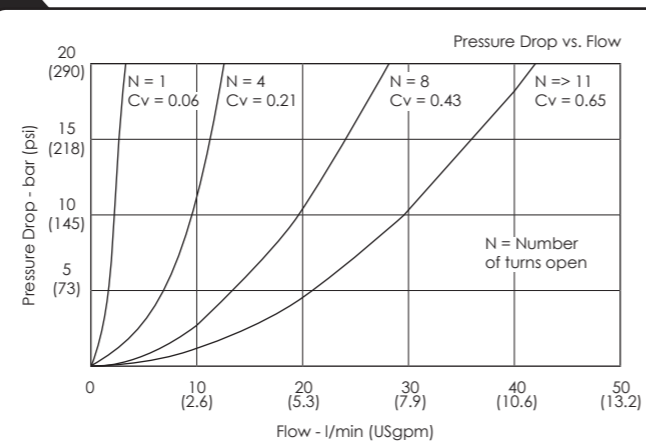

Typical performance based on water

### Installation Diagram

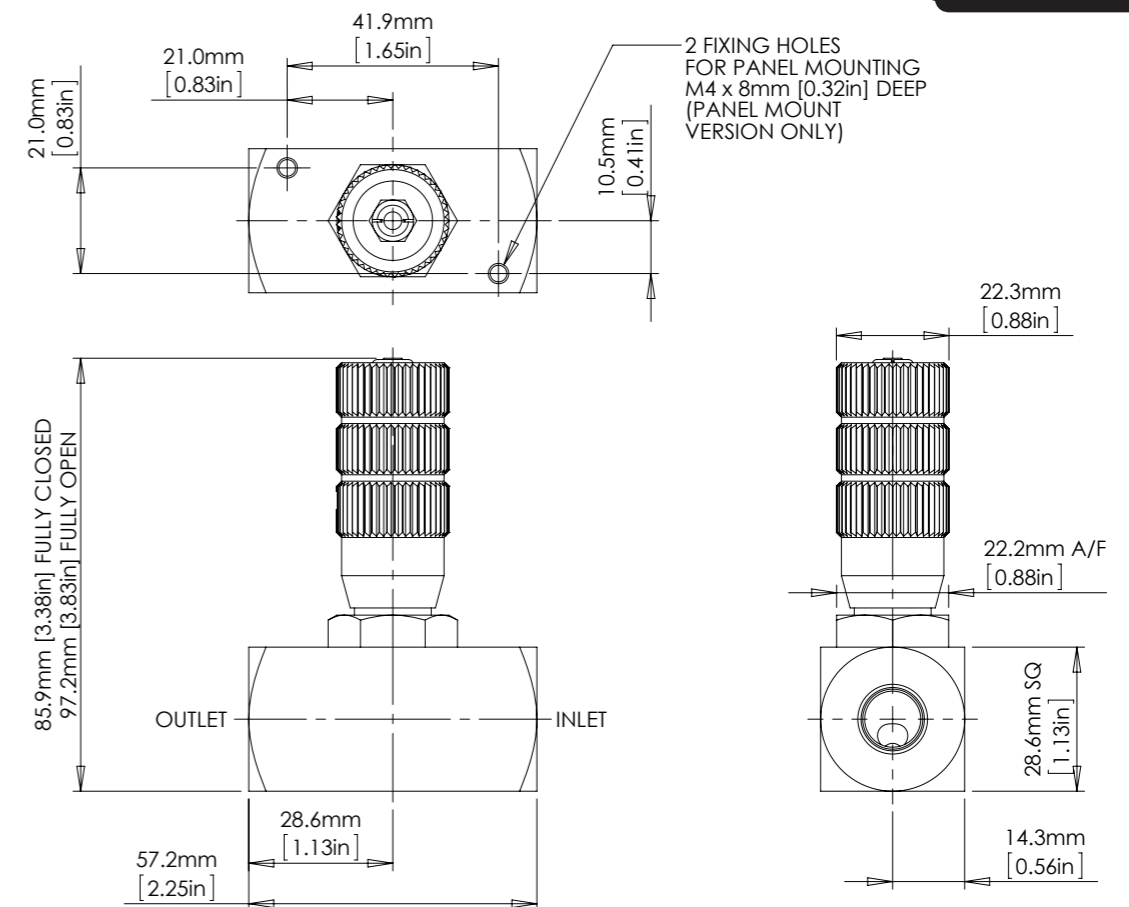

### Product Selector

FMF25 P - PM - NBR - 8K

VALVE TYPE	PORTING OPTIONS	VALVE OPTIONS	SEAL OPTIONS	MAX WORKING PRESSURE
FMF25	<p><b>P</b> 1/4" BSPP female</p> <p><b>N</b> 1/4" NPT female</p>	<p><b>PM</b> Panel mount</p> <p><i>Leave blank if not required</i></p>	<p><b>NBR</b> Nitrile seals -30°C to +105°C</p> <p><b>HNBR</b> Hydrogenated Nitrile seals -20°C to +120°C</p> <p><b>EP</b> EPDM seals -45°C to +120°C</p> <p><b>KLZ</b> Kalrez seals -25°C to +120°C</p> <p><i>Further seal options are available on request</i></p> <p>⚠ Exposure to high and low fluid temperatures will influence handle temperature. Operator safety must be considered</p>	<p><b>8K</b> 552 bar (8,000 psi) Liquid</p> <p>276 bar (4,000 psi) Gas</p>



Catalogue also available on digital media  
Visit our website for a full online search facility  
[www.bisvalves.co.uk](http://www.bisvalves.co.uk)



**BS VALVES**  
The Specifier's Catalogue

SOLENOID  
FLOW CONTROL  
3 PORT DIRECTIONAL CONTROL  
4 PORT DIRECTIONAL CONTROL  
CHECK AND SHUTTLE  
PILOT OPERATED CHECK  
RELIEF  
EXCESS FLOW  
FILTERS  
PRESSURE SENSING  
PUMPS  
ACTUATORS  
TECHNICAL DATA

# VFMF25

## METERING VALVE

1/4" UP TO 552 BAR 8,000 PSI

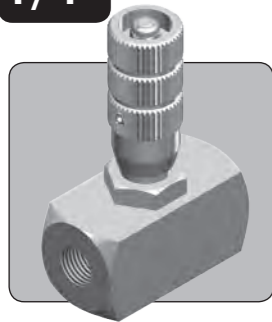

The VFMF25 is a very fine flow metering valve, adjustable via a micrometer style handle. The valve is marked with a preferred direction of flow, but it may be used in the opposite direction to provide bi-directional speed control of a cylinder or actuator, although the level of metering will vary depending on direction.

Note that this valve is not intended to provide tight shut-off when closed.

- Very fine flow control valve for metering applications
- Micrometer style adjustment with engraved graduations
- Lockable adjustment
- Non-rotating valve stem protects valve seat
- Suitable for short term subsea use
- Suitable for liquid or gas
- Suitable for use with air, nitrogen, sweet natural gas, mineral oils, water glycols and plain water
- Suitable for many other media. Contact us for advice
- Cartridge and manifold mount versions available. Contact us for advice
- Various porting and seal options available

### Specifications

**BASIC MODEL NUMBER**

**VFMF25**

**SYMBOL**



**MAX WORKING PRESSURE (LIQUID)**

552 bar  
(8,000 psi)

**MAX WORKING PRESSURE (GAS)**

276 bar  
(4,000 psi)

**CV (FLOW CAPACITY)**

Up to 0.028  
See Typical Performance Graph

**FLUID**

Liquids and Gases  
See materials section

**TEMPERATURE RANGE**

See Product Selector opposite and Technical Data section

**PORT SIZE**

1/4"

**WEIGHT**

0.45 kg  
(1.0lb)

Specifications may change without notice

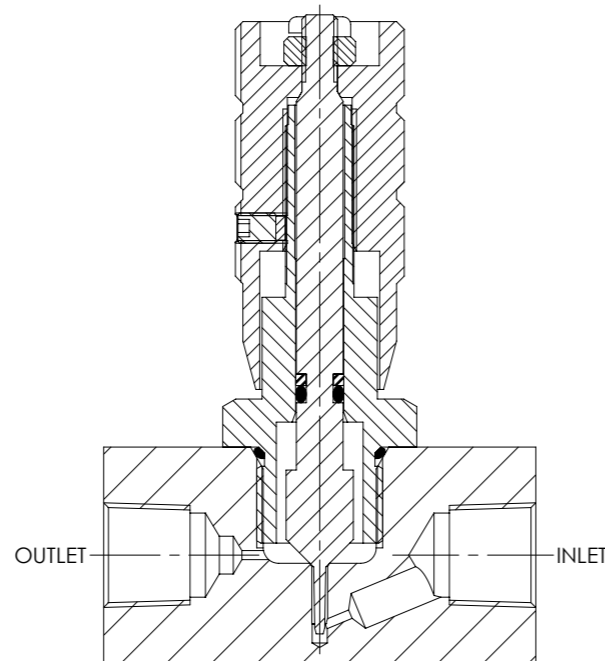

### Materials

Externally Exposed Parts: 316, 304 and 17-4 PH stainless steel.

Internally Wetted Parts: 316 and 17-4 PH stainless steel and PTFE.

The standard valve is designed for use with air, nitrogen, sweet natural gas, mineral oil, water glycols and plain water and may also be used with a wide variety of media compatible with the materials of construction. Other material options are available. Contact us for advice.

⚠ The standard valve has Viton® seals. Further seal options are available via the Product Selector. Compatibility with the working fluid at the operating temperature must be considered.

### Typical Performance

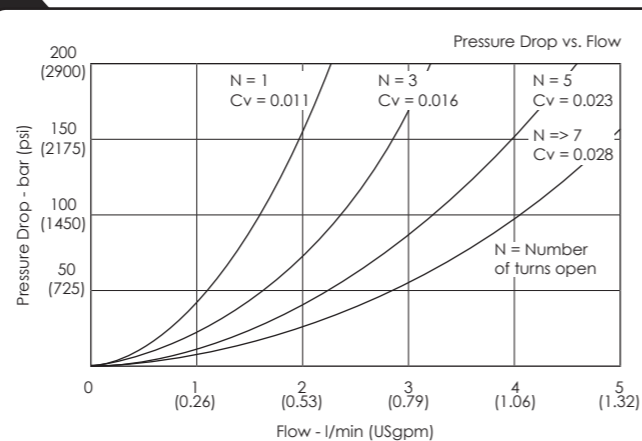

Typical performance based on water

### Installation Diagram

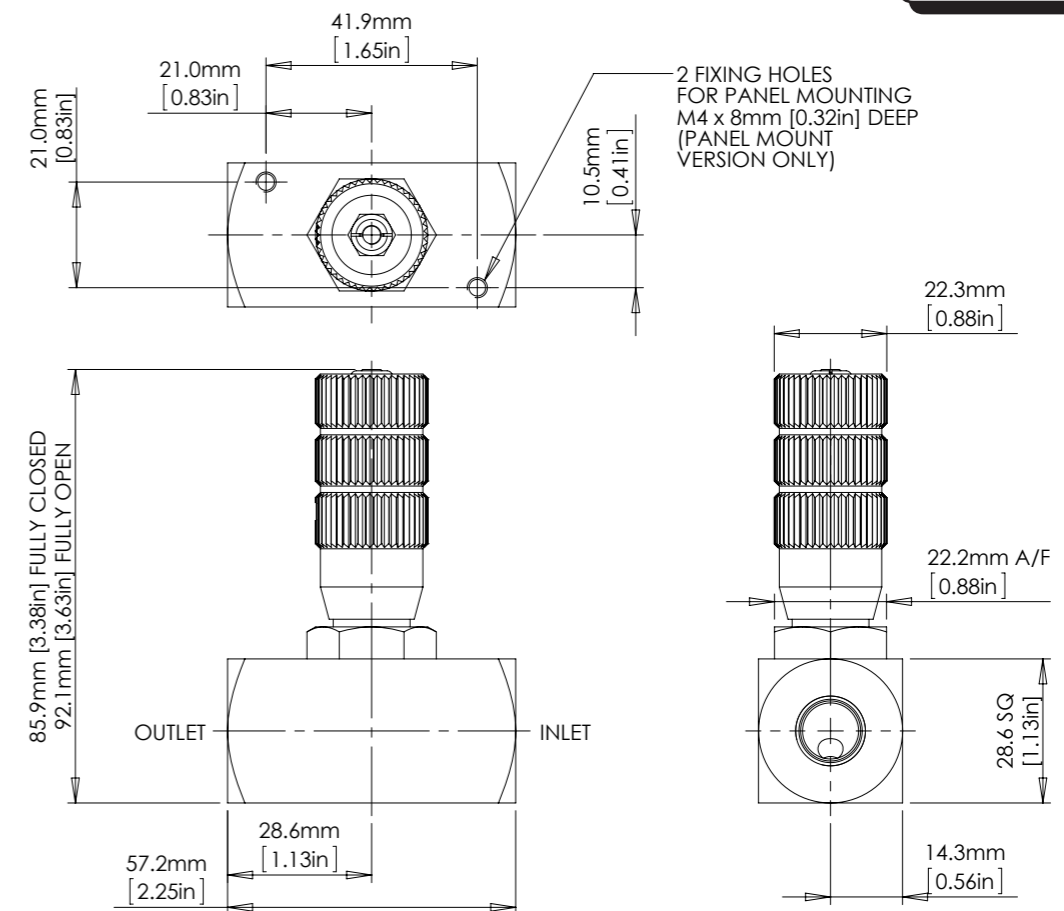

### Product Selector

VFMF25 P - PM - NBR - 8K

VALVE TYPE	PORTING OPTIONS	VALVE OPTIONS	SEAL OPTIONS	MAX WORKING PRESSURE
VFMF25	<p><b>P</b> 1/4" BSPP female</p> <p><b>N</b> 1/4" NPT female</p>	<p><b>PM</b> Panel mount</p> <p><i>Leave blank if not required</i></p>	<p><b>NBR</b> Nitrile seals -30°C to +105°C</p> <p><b>HNBR</b> Hydrogenated Nitrile seals -20°C to +120°C</p> <p><b>EP</b> EPDM seals -45°C to +120°C</p> <p><b>KLZ</b> Kalrez seals -25°C to +120°C</p> <p><i>Further seal options are available on request</i></p> <p>⚠ Exposure to high and low fluid temperatures will influence handle temperature. Operator safety must be considered</p>	<p><b>8K</b> 552 bar (8,000 psi) Liquid</p> <p>276 bar (4,000 psi) Gas</p>



Catalogue also available on digital media  
Visit our website for a full online search facility  
[www.bisvalves.co.uk](http://www.bisvalves.co.uk)



**BS VALVES**  
The Specifier's Catalogue

SOLENOID  
FLOW CONTROL  
3 PORT DIRECTIONAL CONTROL  
4 PORT DIRECTIONAL CONTROL  
CHECK AND SHUTTLE  
PILOT OPERATED CHECK  
RELIEF  
EXCESS FLOW  
FILTERS  
PRESSURE SENSING  
PUMPS  
ACTUATORS  
TECHNICAL DATA

# MF37 METERING VALVE

**3/8" UP TO 552 BAR 8,000 PSI**

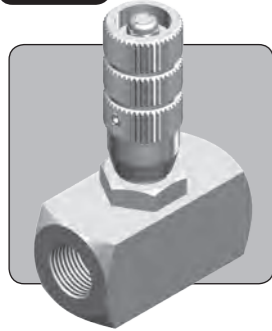

The MF37 is a 3/8" nominal bore flow metering valve, adjustable via a micrometer style handle. The valve is marked with a preferred direction of flow, but it may be used in the opposite direction to provide bi-directional speed control of a cylinder or actuator, although the level of metering will vary depending on direction.

Note that this valve is not intended to provide tight shut-off when closed.

- Flow control valve for metering applications
- Micrometer style adjustment with engraved graduations
- Lockable adjustment
- Non-rotating valve stem protects valve seat
- Suitable for short term subsea use
- Suitable for liquid or gas
- Suitable for use with air, nitrogen, sweet natural gas, mineral oils, water glycols and plain water
- Suitable for many other media. Contact us for advice
- Panel mount versions available
- Various porting options available
- Various seal options available

## Specifications

**BASIC MODEL NUMBER**

**MF37**

**SYMBOL**



**MAX WORKING PRESSURE (LIQUID)**

552 bar  
(8,000 psi)

**MAX WORKING PRESSURE (GAS)**

276 bar  
(4,000 psi)

**CV (FLOW CAPACITY)**

Up to 0.65  
See Typical Performance Graph

**FLUID**

Liquids and Gases  
See materials section

**TEMPERATURE RANGE**

See Product Selector opposite  
and Technical Data section

**PORT SIZE**

3/8"

**WEIGHT**

0.4 kg  
(0.9 lb)

Specifications may change without notice

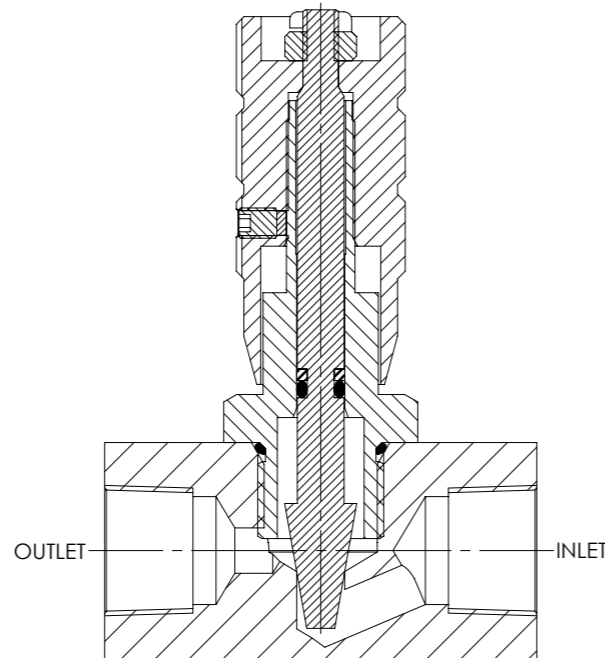

## Materials

Externally Exposed Parts: 316, 304 and 17-4 PH stainless steel.

Internally Wetted Parts: 316 and 17-4 PH stainless steel and acetal.

The standard valve is designed for use with air, nitrogen, sweet natural gas, mineral oil, water glycols and plain water and may also be used with a wide variety of media compatible with the materials of construction. Other material options are available. Contact us for advice.

⚠ The standard valve has Viton® seals. Further seal options are available via the Product Selector. Compatibility with the working fluid at the operating temperature must be considered.

## Typical Performance

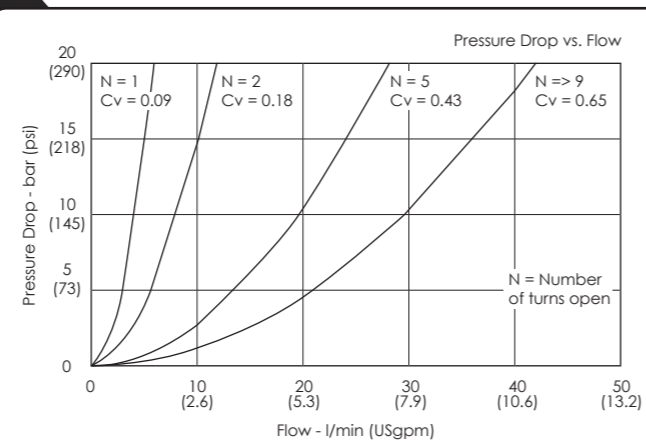

Typical performance based on water glycol

## Installation Diagram

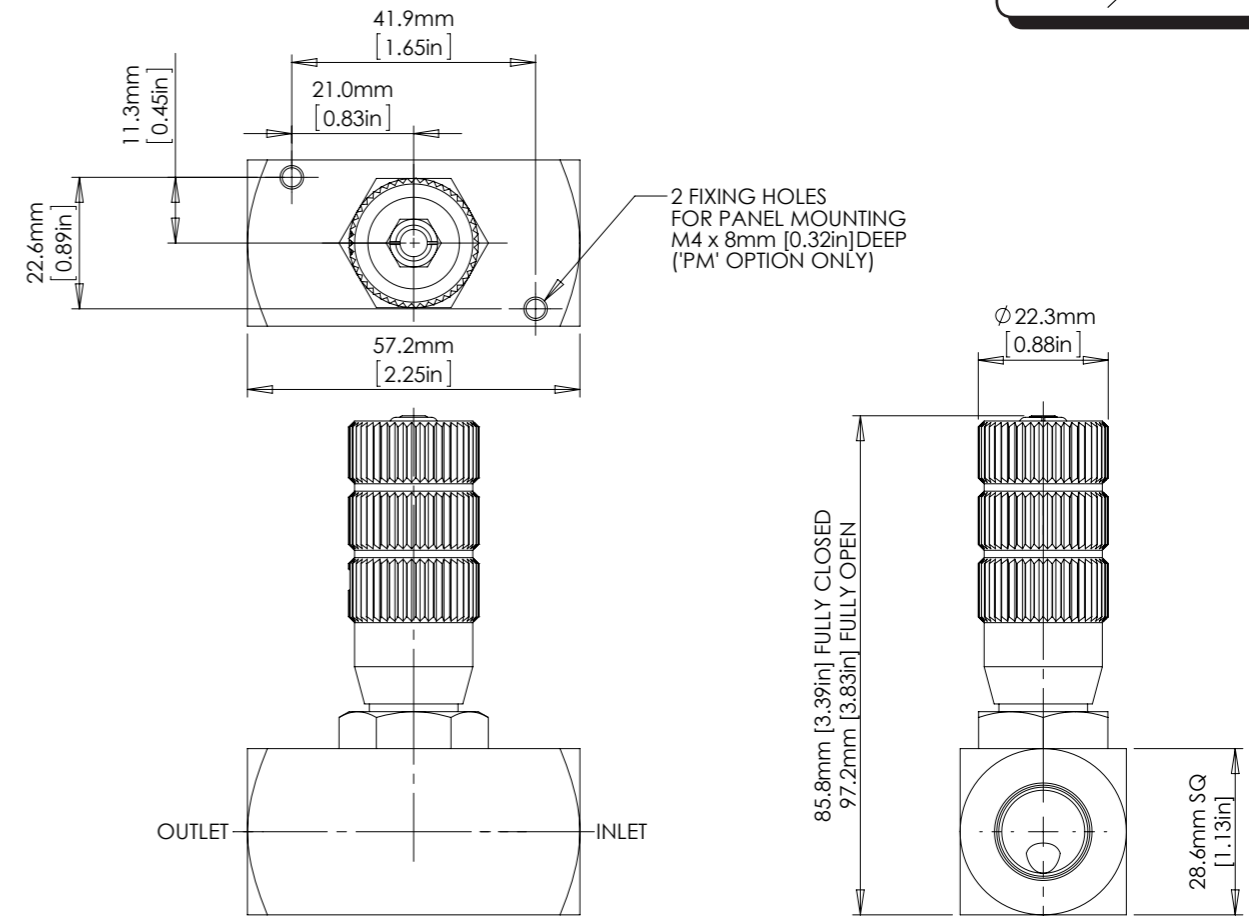

## Product Selector

**MF37 P - PM - NBR - 8K**

VALVE TYPE	PORTING OPTIONS	VALVE OPTIONS	SEAL OPTIONS	MAX WORKING PRESSURE
<b>MF37</b>	<b>P</b> 3/8" BSPP female	<b>PM</b> Panel mount	<b>NBR</b> Nitrile seals -30°C to +105°C	<b>8K</b> 552 bar (8,000 psi) Liquid
	<b>N</b> 3/8" NPT female	Leave blank if not required	<b>HNBR</b> Hydrogenated Nitrile seals -20°C to +120°C	276 bar (4,000 psi) Gas
			<b>EP</b> EPDM seals -45°C to +120°C	
			<b>KLZ</b> Kalrez seals -25°C to +120°C	

Repair and seal kits are available on request

For a seal kit add SK at the end of the model code and for a repair kit add RK

Further seal options are available on request

⚠ Exposure to high and low fluid temperatures will influence handle temperature. Operator safety must be considered



Catalogue also available on digital media  
Visit our website for a full online search facility  
[www.bisvalves.co.uk](http://www.bisvalves.co.uk)



**BS VALVES**  
The Specifier's Catalogue

SOLENOID  
FLOW CONTROL  
3 PORT DIRECTIONAL CONTROL  
4 PORT DIRECTIONAL CONTROL  
CHECK AND SHUTTLE  
PILOT OPERATED CHECK  
RELIEF  
EXCESS FLOW  
FILTERS  
PRESSURE SENSING  
PUMPS  
ACTUATORS  
TECHNICAL DATA



# MF50 METERING VALVE

**1/2" UP TO 552 BAR 8,000 PSI**

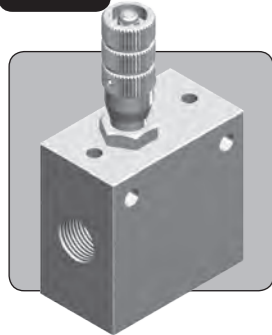

The MF50 is a 1/2" nominal bore flow metering valve, adjustable via a micrometer style handle. The valve is marked with a preferred direction of flow, but it may be used in the opposite direction to provide bi-directional speed control of a cylinder or actuator, although the level of metering will vary depending on direction.

Note that this valve is not intended to provide tight shut-off when closed.

- Flow control valve for metering applications
- Micrometer style adjustment with engraved graduations
- Lockable adjustment
- Non-rotating valve stem protects valve seat
- Suitable for liquid or gas
- Suitable for use with air, nitrogen, sweet natural gas, mineral oils, water glycols and plain water
- Suitable for many other media. Contact us for advice
- Panel mountable as standard
- Various porting options available
- Various seal options available

## Specifications

<b>BASIC MODEL NUMBER</b>	<b>MF50</b>
<b>SYMBOL</b>	INLET  OUTLET
<b>MAX WORKING PRESSURE (LIQUID)</b>	552 bar (8,000 psi)
<b>MAX WORKING PRESSURE (GAS)</b>	276 bar (4,000 psi)
<b>CV (FLOW CAPACITY)</b>	Up to 1.4 <i>See Typical Performance Graph</i>
<b>FLUID</b>	Liquids and Gases <i>See materials section</i>
<b>TEMPERATURE RANGE</b>	<i>See Product Selector opposite and Technical Data section</i>
<b>PORT SIZE</b>	1/2"
<b>WEIGHT</b>	2.0 kg (4.4 lb)

Specifications may change without notice

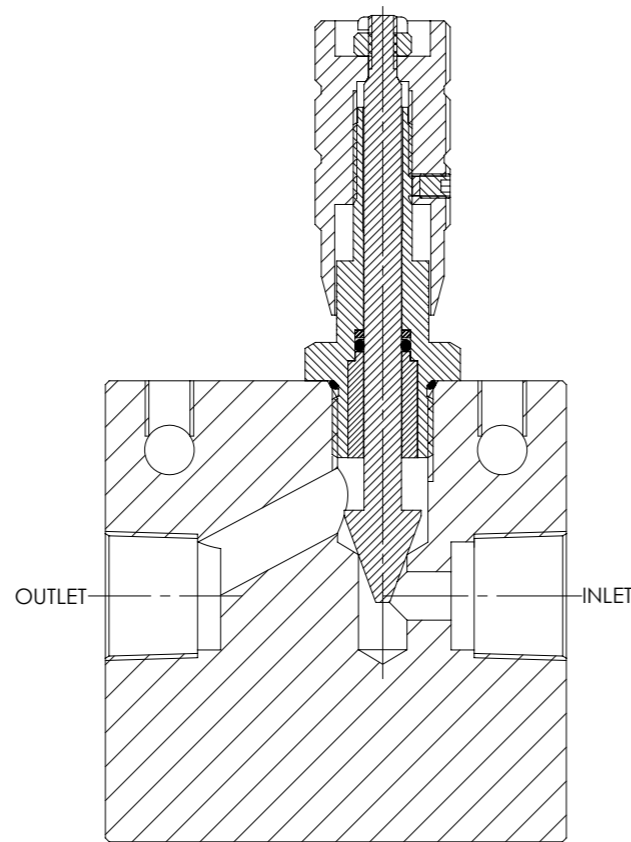

## Materials

Externally Exposed Parts: 316, 304 and 17-4 PH stainless steel.

Internally Wetted Parts: 316 and 17-4 PH stainless steel and acetal.

The standard valve is designed for use with air, nitrogen, sweet natural gas, mineral oil, water glycols and plain water, but may be used with a wide variety of media compatible with the materials of construction. Other material options are available and for further advice, please contact us.

 The standard valve has Viton® seals. Further seal options are available via the Product Selector. Compatibility with the working fluid at the operating temperature must be considered.

## Typical Performance

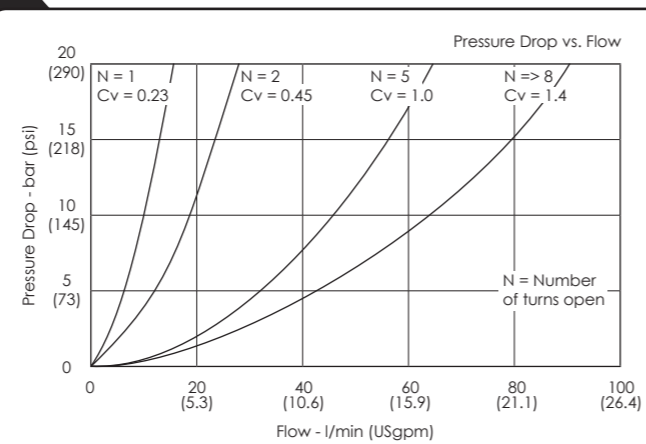

Typical performance based on water

## Installation Diagram

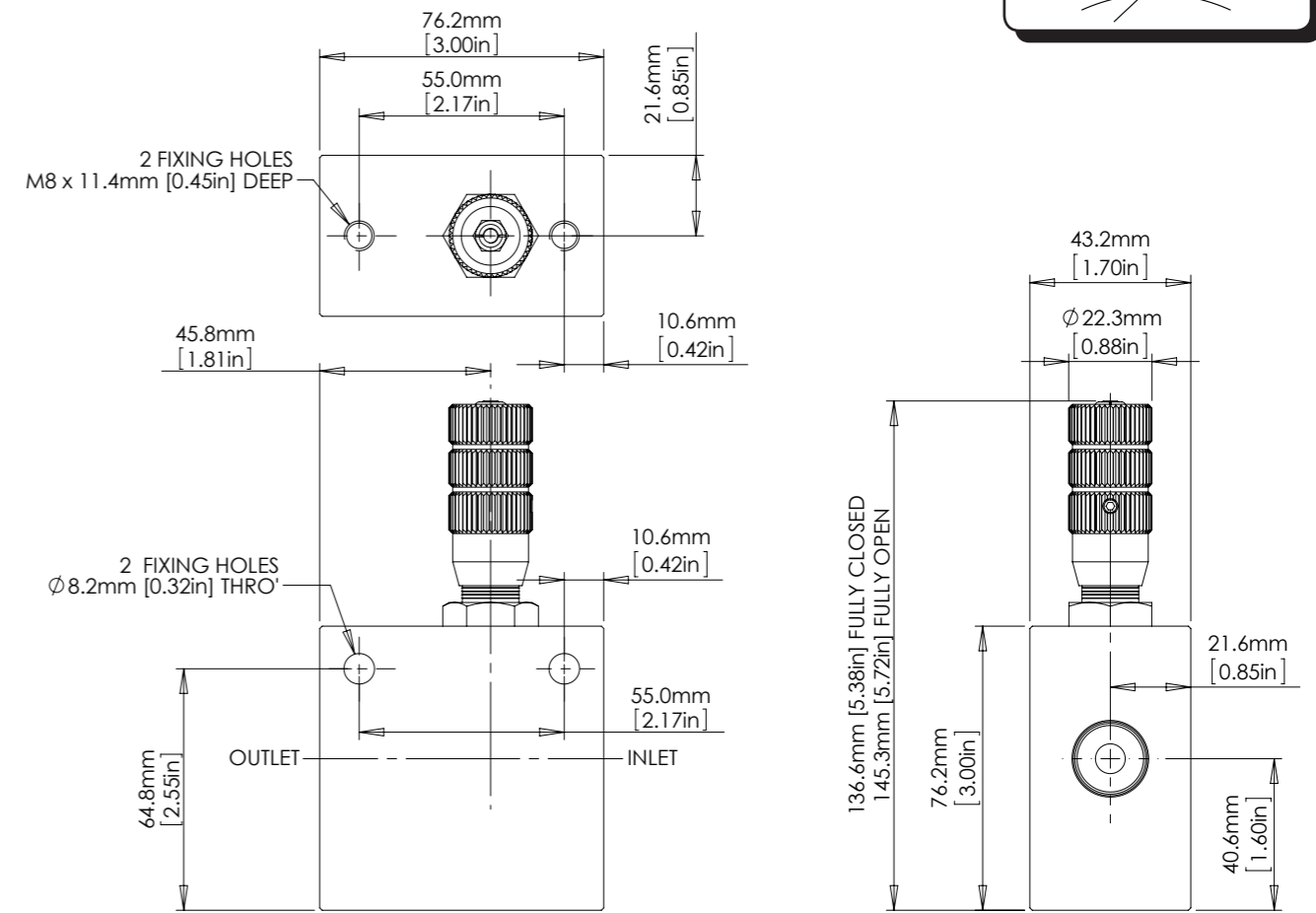

## Product Selector

MF50 P - NBR - 8K			
VALVE TYPE	PORTING OPTIONS	SEAL OPTIONS	MAX WORKING PRESSURE
<b>MF50</b>	<b>P</b> 1/2" BSPP female	Leave blank for Viton® seals -10°C to +120°C	<b>8K</b> 552 bar (8,000 psi) Liquid
	<b>N</b> 1/2" NPT female	<b>NBR</b> Nitrile seals -30°C to +105°C	276 bar (4,000 psi) Gas
		<b>EP</b> EPDM seals -45°C to +120°C	
		<b>KLZ</b> Kalrez® seals -25°C to +120°C	
		<b>HNBR</b> Hydrogenated Nitrile seals -20°C to +120°C	

Repair and seal kits are available on request

For a seal kit add SK at the end of the model code and for a repair kit add RK

 Exposure to high and low fluid temperatures will influence handle temperature. Operator safety must be considered.



Catalogue also available on digital media  
Visit our website for a full online search facility  
[www.bisvalves.co.uk](http://www.bisvalves.co.uk)

SOLENOID  
FLOW CONTROL  
3 PORT DIRECTIONAL CONTROL  
4 PORT DIRECTIONAL CONTROL  
CHECK AND SHUTTLE  
PILOT OPERATED CHECK  
RELIEF  
EXCESS FLOW  
FILTERS  
PRESSURE SENSING  
PUMPS  
ACTUATORS  
TECHNICAL DATA

# MF75 METERING VALVE

**3/4" UP TO 552 BAR 8,000 PSI**

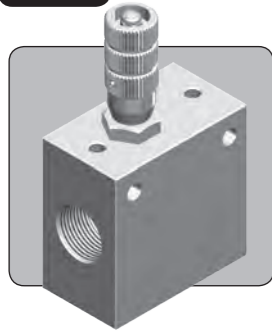

The MF75 is a 3/4" nominal bore flow metering valve, adjustable via a micrometer style handle. The valve is marked with a preferred direction of flow, but it may be used in the opposite direction to provide bi-directional speed control of a cylinder or actuator, although the level of metering will vary depending on direction.

Note that this valve is not intended to provide tight shut-off when closed.

- Flow control valve for metering applications
- Micrometer style adjustment with engraved graduations
- Lockable adjustment
- Non-rotating valve stem protects valve seat
- Suitable for liquid or gas
- Suitable for use with air, nitrogen, sweet natural gas, mineral oils, water glycols and plain water
- Suitable for many other media. Contact us for advice
- Panel mountable as standard
- Various porting options available
- Various seal options available

## Specifications

**BASIC MODEL NUMBER** **MF75**

**SYMBOL** INLET  OUTLET

**MAX WORKING PRESSURE (LIQUID)** 552 bar (8,000 psi)

**MAX WORKING PRESSURE (GAS)** 276 bar (4,000 psi)

**CV (FLOW CAPACITY)** Up to 2.5  
*See Typical Performance Graph*

**FLUID** Liquids and Gases  
*See materials section*

**TEMPERATURE RANGE** *See Product Selector opposite and Technical Data section*

**PORT SIZE** 3/4"

**WEIGHT** 1.9 kg (4.1 lb)

*Specifications may change without notice*

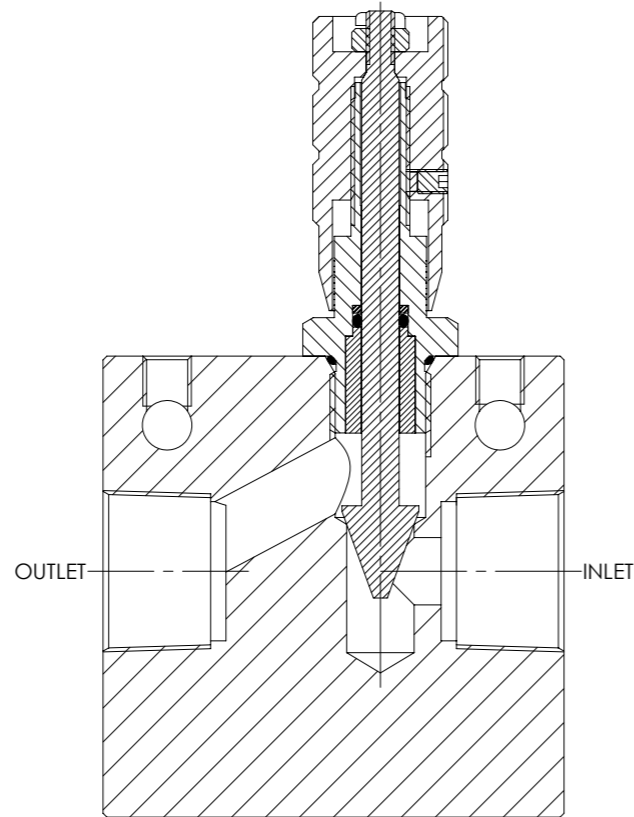

## Materials

Externally Exposed Parts: 316, 304 and 17-4 PH stainless steel.

Internally Wetted Parts: 316 and 17-4 PH stainless steel and acetal.

The standard valve is designed for use with air, nitrogen, sweet natural gas, mineral oil, water glycols and plain water, but may be used with a wide variety of media compatible with the materials of construction. Other material options are available and for further advice, please contact us.

 The standard valve has Viton® seals. Further seal options are available via the Product Selector. Compatibility with the working fluid at the operating temperature must be considered.

## Typical Performance

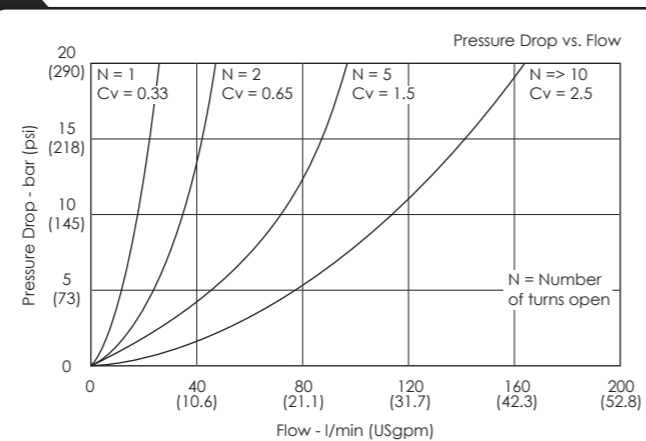

*Typical performance based on water*

## Installation Diagram

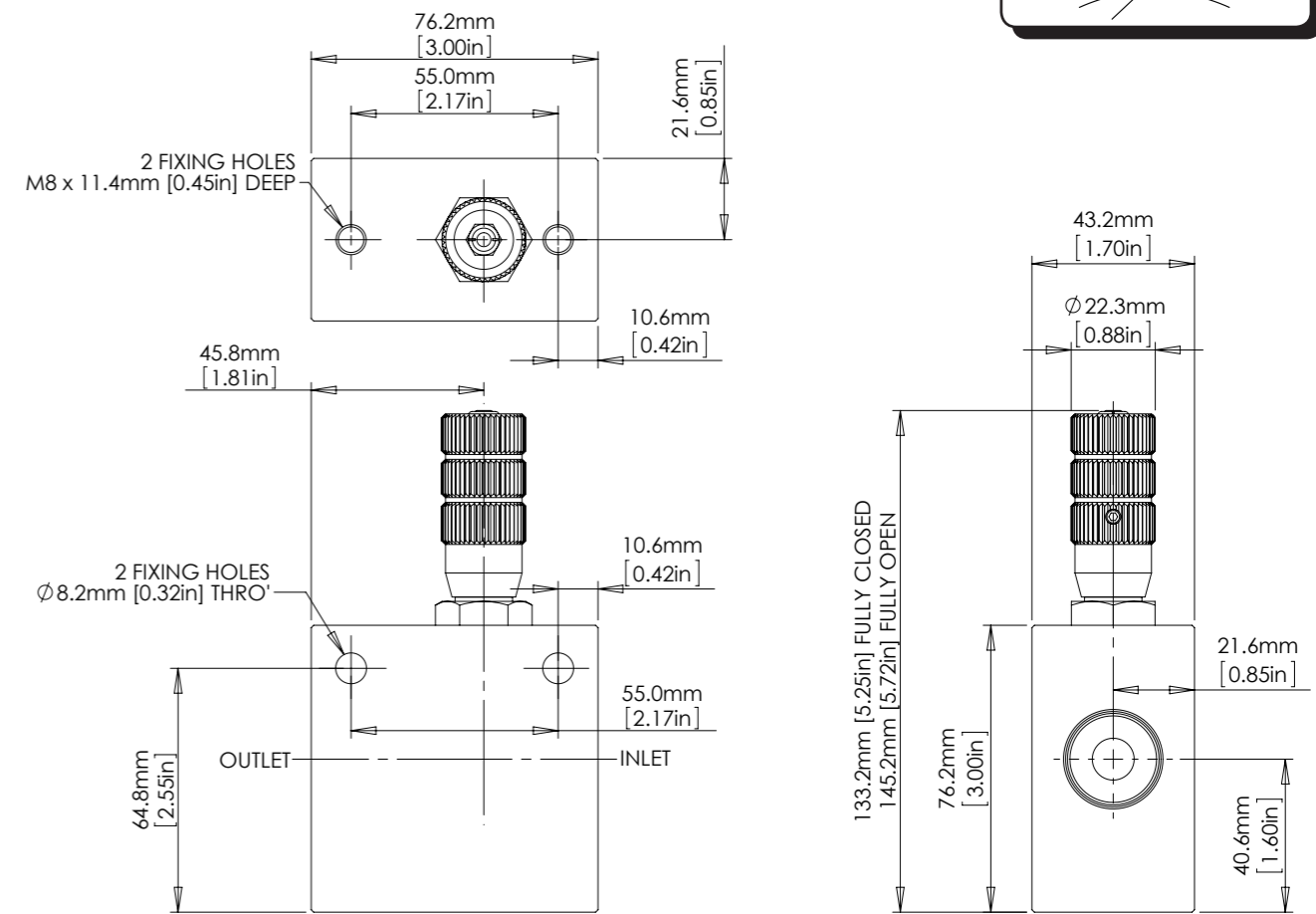

## Product Selector

MF75 P - NBR - 8K			
VALVE TYPE	PORTING OPTIONS	SEAL OPTIONS	MAX WORKING PRESSURE
MF75	<p><b>P</b> 3/4" BSPP female</p> <p><b>N</b> 3/4" NPT female</p>	<p>Leave blank for Viton® seals -10°C to +120°C</p> <p><b>NBR</b> Nitrile seals -30°C to +105°C</p> <p><b>EP</b> EPDM seals -45°C to +120°C</p> <p><b>KLZ</b> Kalrez® seals -25°C to +120°C</p> <p><b>HNBR</b> Hydrogenated Nitrile seals -20°C to +120°C</p> <p><i>Further seal options are available on request</i></p> <p> Exposure to high and low fluid temperatures will influence handle temperature. Operator safety must be considered.</p>	<p><b>8K</b> 552 bar (8,000 psi) Liquid</p> <p>276 bar (4,000 psi) Gas</p>
<p><i>Repair and seal kits are available on request</i></p> <p><i>For a seal kit add SK at the end of the model code and for a repair kit add RK</i></p>			



Catalogue also available on digital media  
Visit our website for a full online search facility  
[www.bisvalves.co.uk](http://www.bisvalves.co.uk)

**BS VALVES**  
The Specifier's Catalogue

SOLENOID  
FLOW CONTROL  
3 PORT DIRECTIONAL CONTROL  
4 PORT DIRECTIONAL CONTROL  
CHECK AND SHUTTLE  
PILOT OPERATED CHECK  
RELIEF  
EXCESS FLOW  
FILTERS  
PRESSURE SENSING  
PUMPS  
ACTUATORS  
TECHNICAL DATA

# MF100 METERING VALVE

1"

UP TO 552 BAR 8,000 PSI

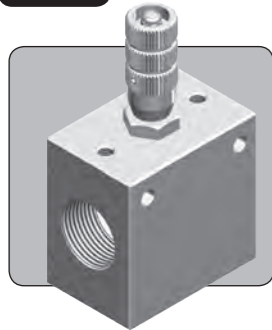

The MF100 is a 1" nominal bore flow metering valve, adjustable via a micrometer style handle. The valve is marked with a preferred direction of flow, but it may be used in the opposite direction to provide bi-directional speed control of a cylinder or actuator, although the level of metering will vary depending on direction.

Note that this valve is not intended to provide tight shut-off when closed.

- Flow control valve for metering applications
- Micrometer style adjustment with engraved graduations
- Lockable adjustment
- Non-rotating valve stem protects valve seat
- Suitable for liquid or gas
- Suitable for use with air, nitrogen, sweet natural gas, mineral oils, water glycols and plain water
- Suitable for many other media. Contact us for advice
- Panel mountable as standard
- Various porting options available
- Various seal options available

## Specifications

**BASIC MODEL NUMBER**

**MF100**

**SYMBOL**



**MAX WORKING PRESSURE (LIQUID)**

552 bar  
(8,000 psi)

**MAX WORKING PRESSURE (GAS)**

276 bar  
(4,000 psi)

**CV (FLOW CAPACITY)**

Up to 2.5  
See Typical Performance Graph

**FLUID**

Liquids and Gases  
See materials section

**TEMPERATURE RANGE**

See Product Selector opposite  
and Technical Data section

**PORT SIZE**

1"

**WEIGHT**

2.1 kg  
(4.6 lb)

Specifications may change without notice

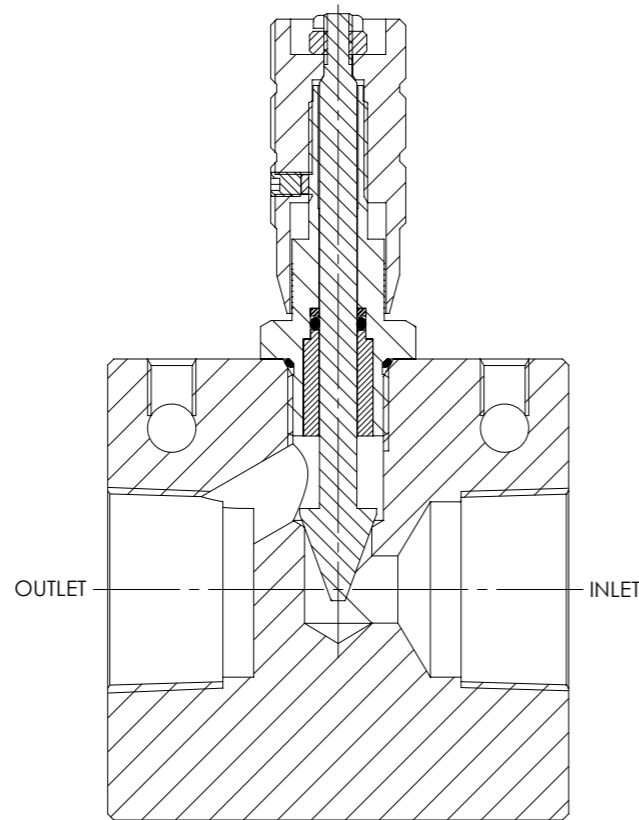

## Materials

Externally Exposed Parts: 316, 304 and 17-4 PH stainless steel.

Internally Wetted Parts: 316 and 17-4 PH stainless steel and acetal.

The standard valve is designed for use with air, nitrogen, sweet natural gas, mineral oil, water glycols and plain water, but may be used with a wide variety of media compatible with the materials of construction. Other material options are available and for further advice, please contact us.

⚠ The standard valve has Viton® seals. Further seal options are available via the Product Selector. Compatibility with the working fluid at the operating temperature must be considered.

## Typical Performance

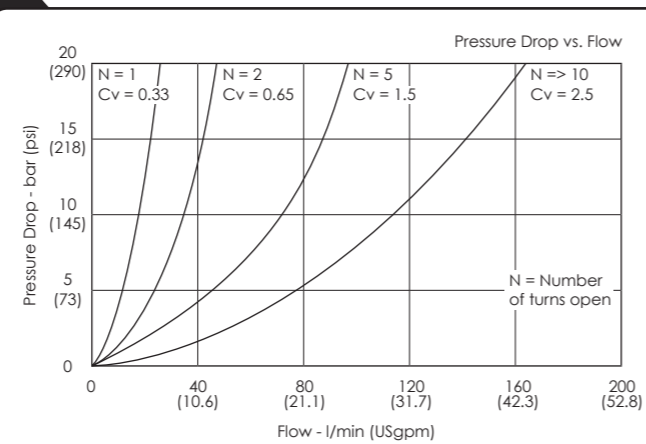

Typical performance based on water

## Installation Diagram

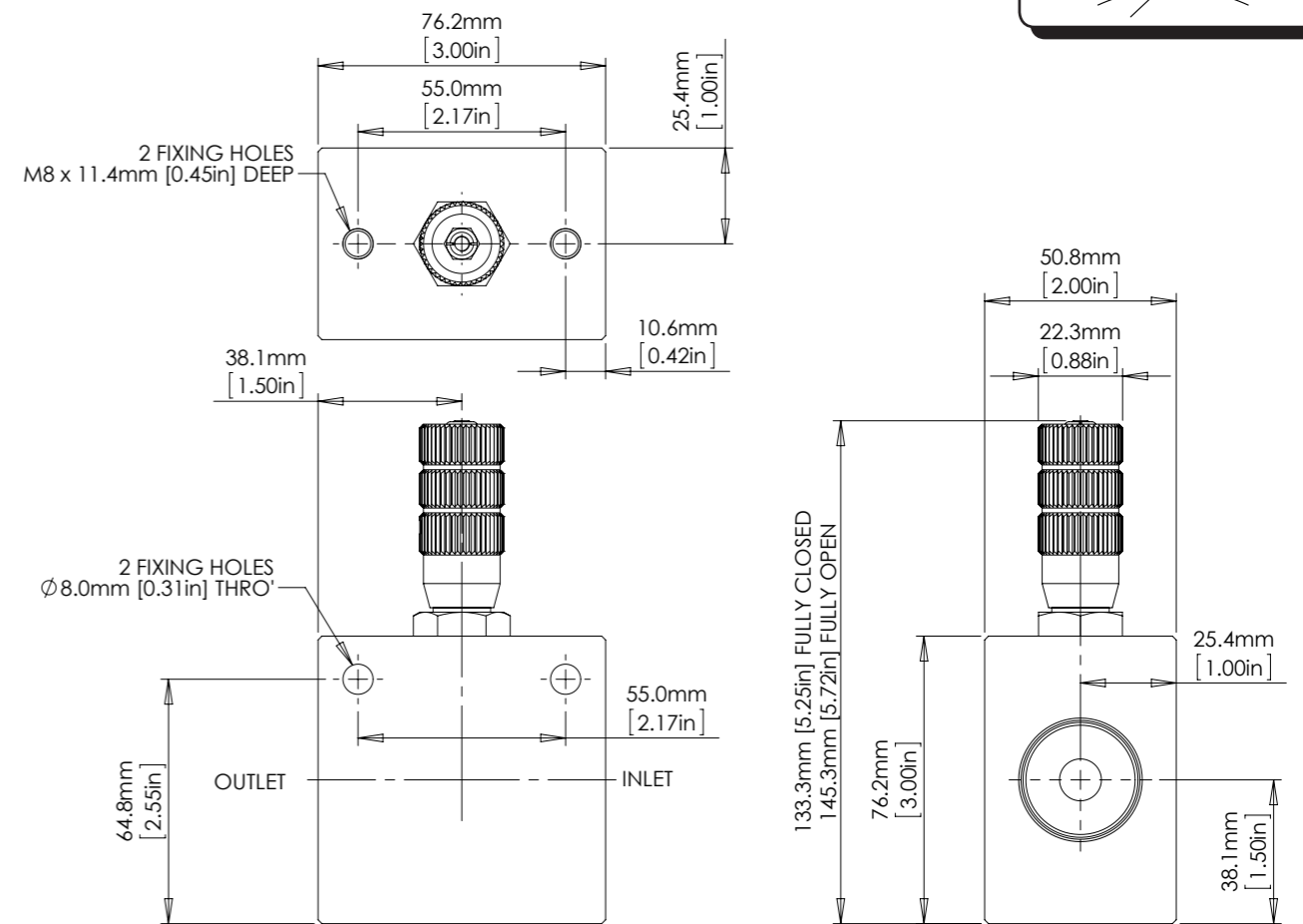

## Product Selector

MF100 P - NBR - 8K			
VALVE TYPE	PORTING OPTIONS	SEAL OPTIONS	MAX WORKING PRESSURE
MF100	<p><b>P</b> 1" BSPF female</p> <p><b>N</b> 1" NPT female</p>	<p>Leave blank for Viton® seals -10°C to +120°C</p> <p><b>NBR</b> Nitrile seals -30°C to +105°C</p> <p><b>EP</b> EPDM seals -45°C to +120°C</p> <p><b>KLZ</b> Kalrez® seals -25°C to +120°C</p> <p><b>HNBR</b> Hydrogenated Nitrile seals -20°C to +120°C</p> <p>Further seal options are available on request</p> <p>⚠ Exposure to high and low fluid temperatures will influence handle temperature. Operator safety must be considered.</p>	<p><b>8K</b> 552 bar (8,000 psi) Liquid</p> <p>276 bar (4,000 psi) Gas</p>
<p>Repair and seal kits are available on request</p> <p>For a seal kit add SK at the end of the model code and for a repair kit add RK</p>			



Catalogue also available on digital media  
Visit our website for a full online search facility  
[www.bisvalves.co.uk](http://www.bisvalves.co.uk)



**BS VALVES**  
The Specifier's Catalogue

Page 27

# CMF25

## METERING VALVE

1/4" UP TO 552 BAR 8,000 PSI

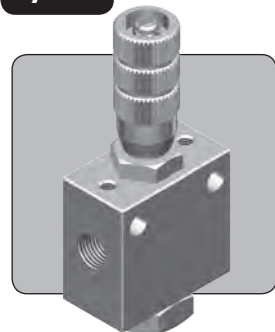

The CMF25 is a 1/4" nominal bore metering valve with a reverse free-flow check function. It provides metered flow in one direction, and free flow in the opposite direction, ideal for uni-directional speed control of a cylinder or actuator.

The valve can be adjusted manually after installation, and the setting can be locked.

Note that this is a flow control valve and is not intended to provide tight shut-off when closed.

- Metering valve with reverse free-flow check feature
- Micrometer style adjustment with engraved graduations
- Non-rotating valve stem with lockable adjustment
- Ideal for uni-directional speed control
- Stainless steel construction suitable for liquid or gas
- Can be panel mounted
- Suitable for use with air, nitrogen, sweet natural gas, mineral oils, water glycols and many other media
- NACE MR01-75 compliant version available
- Various porting options available. Manifold mounted version available on request
- Various seal options available on request

### Specifications

**BASIC MODEL NUMBER**

**CMF25**

**SYMBOL**

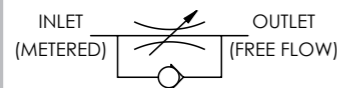

**MAX WORKING PRESSURE (LIQUID)** 552 bar (8,000 psi)

**MAX WORKING PRESSURE (GAS)** 276 bar (4,000 psi)

**CV (FLOW CAPACITY)** Up to 0.62  
See Typical Performance Graph

**FLUID** Liquids and Gases  
See materials section

**TEMPERATURE RANGE** See Product Selector opposite and Technical Data section

**PORT SIZE** 1/4"

**CHECK ELEMENT CRACKING PRESSURE** 0.2 - 0.5 bar (3 - 7 psi)

**WEIGHT** 0.70 kg (1.5 lb)

Specifications may change without notice

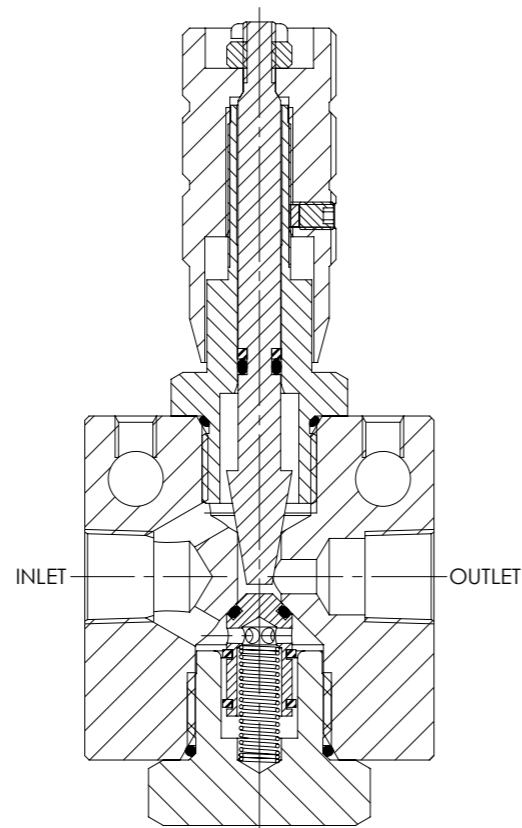

### Materials

Externally Exposed Parts: 316, 302 and 17-4 PH stainless steel.

Internally Wetted Parts: 316, 302 and 17-4 PH stainless steel, and acetal.

The standard valve is designed for use with air, nitrogen, sweet natural gas, mineral oil, water glycols and plain water, but may be used with a wide variety of media compatible with the materials of construction. Other material options are available and for further advice, please contact us.

⚠ The standard valve has Viton® seals. Further seal options are available via the Product Selector. Compatibility with the working fluid at the operating temperature must be considered.

### Typical Performance

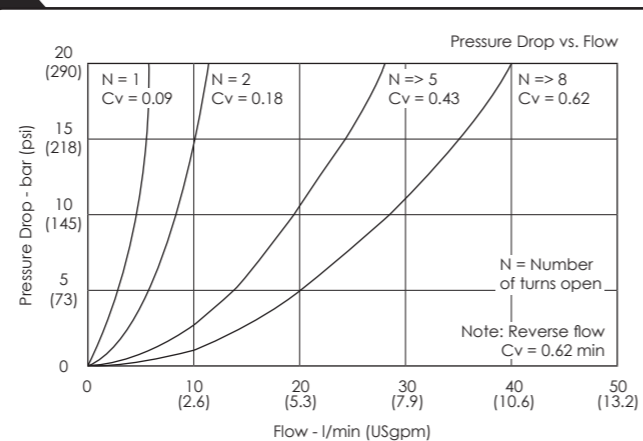

Typical performance based on water glycol

### Installation Diagram

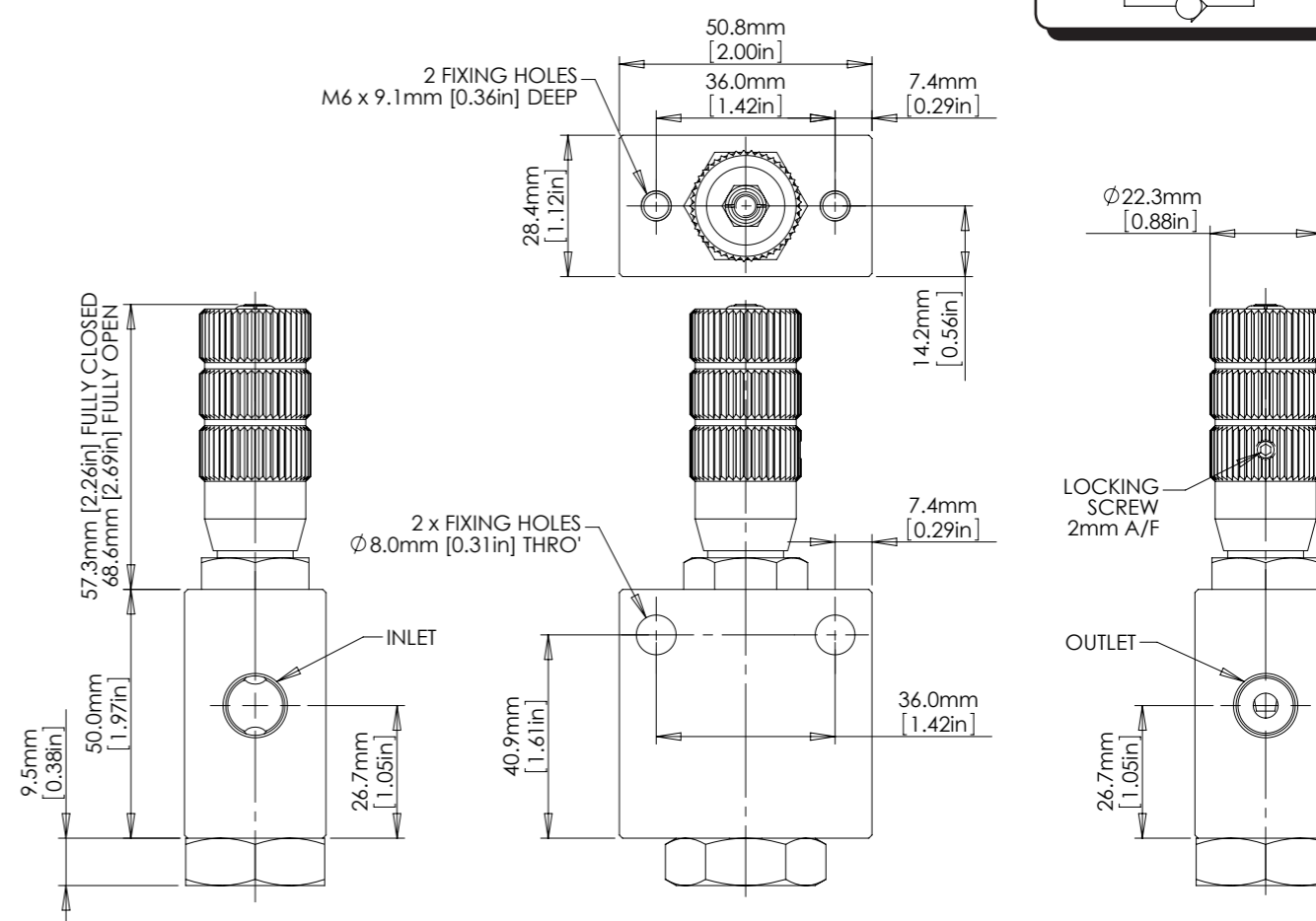

### Product Selector

CMF25 P - NBR - 8K			
VALVE TYPE	PORTING OPTIONS	SEAL OPTIONS	MAX WORKING PRESSURE
CMF25	<p><b>P</b> 1/4" BSPP female</p> <p><b>N</b> 1/4" NPT female</p>	<p>Leave blank for Viton® seals -10°C to +120°C</p> <p><b>NBR</b> Nitrile seals -30°C to +105°C</p> <p><b>EP</b> EPDM seals -45°C to +120°C</p> <p><b>KLZ</b> Kalrez® seals -25°C to +120°C</p> <p><b>HNBR</b> Hydrogenated Nitrile seals -20°C to +120°C</p> <p>Further seal options are available on request</p> <p>⚠ Exposure to high and low fluid temperatures will influence handle temperature. Operator safety must be considered.</p>	<p><b>8K</b> 552 bar (8,000 psi) Liquid</p> <p>276 bar (4,000 psi) Gas</p>

Repair and seal kits are available on request

For a seal kit add SK at the end of the model code and for a repair kit add RK



Catalogue also available on digital media  
Visit our website for a full online search facility  
[www.bisvalves.co.uk](http://www.bisvalves.co.uk)

**BS VALVES**  
The Specifier's Catalogue

SOLENOID  
FLOW CONTROL  
3 PORT DIRECTIONAL CONTROL  
4 PORT DIRECTIONAL CONTROL  
CHECK AND SHUTTLE  
PILOT OPERATED CHECK  
RELIEF  
EXCESS FLOW  
FILTERS  
PRESSURE SENSING  
PUMPS  
ACTUATORS  
TECHNICAL DATA

# CMF37 METERING VALVE

**3/8" UP TO 552 BAR 8,000 PSI**

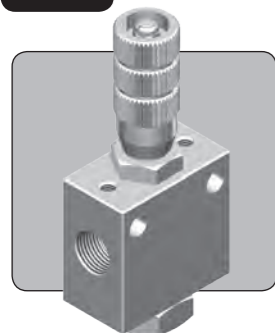

The CMF37 is a 3/8" nominal bore metering valve with a reverse free-flow check function. It provides metered flow in one direction, and free flow in the opposite direction, ideal for uni-directional speed control of a cylinder or actuator.

The valve can be adjusted manually after installation, and the setting can be locked.

Note that this is a flow control valve and is not intended to provide tight shut-off when closed.

- Metering valve with reverse free-flow check feature
- Micrometer style adjustment with engraved graduations
- Non-rotating valve stem with lockable adjustment
- Ideal for uni-directional speed control
- Stainless steel construction suitable for liquid or gas
- Can be panel mounted
- Suitable for use with air, nitrogen, sweet natural gas, mineral oils, water glycols and many other media
- NACE MR01-75 compliant version available
- Various porting options available. Manifold mounted version available on request
- Various seal options available on request

## Specifications

**BASIC MODEL NUMBER**

**CMF37**

**SYMBOL**

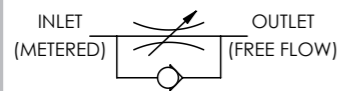

**MAX WORKING PRESSURE (LIQUID)** 552 bar (8,000 psi)

**MAX WORKING PRESSURE (GAS)** 276 bar (4,000 psi)

**CV (FLOW CAPACITY)** Up to 0.62  
See Typical Performance Graph

**FLUID** Liquids and Gases  
See materials section

**TEMPERATURE RANGE** See Product Selector opposite and Technical Data section

**PORT SIZE** 3/8"

**CHECK ELEMENT CRACKING PRESSURE** 0.2 - 0.5 bar (3 - 7 psi)

**WEIGHT** 0.70 kg (1.5 lb)

Specifications may change without notice

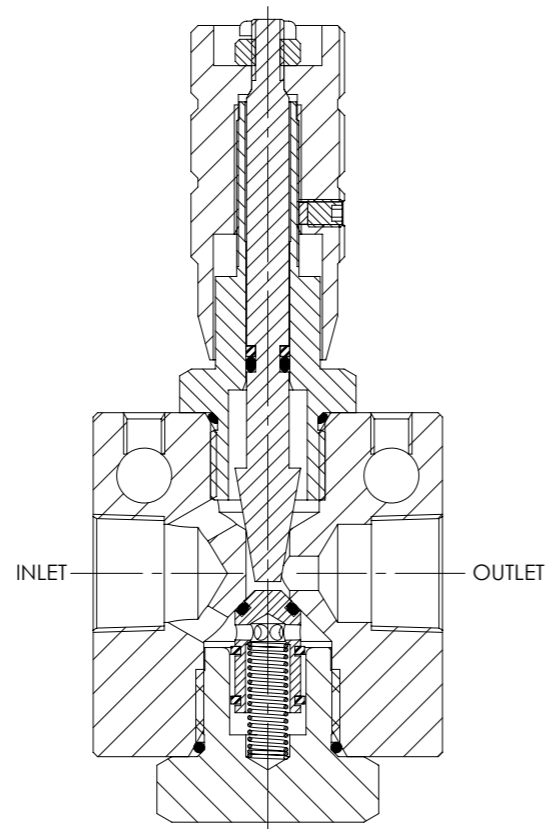

## Materials

Externally Exposed Parts: 316, 302 and 17-4 PH stainless steel.

Internally Wetted Parts: 316, 302 and 17-4 PH stainless steel, and acetal.

The standard valve is designed for use with air, nitrogen, sweet natural gas, mineral oil, water glycols and plain water, but may be used with a wide variety of media compatible with the materials of construction. Other material options are available and for further advice, please contact us.

⚠ The standard valve has Viton® seals. Further seal options are available via the Product Selector. Compatibility with the working fluid at the operating temperature must be considered.

## Typical Performance

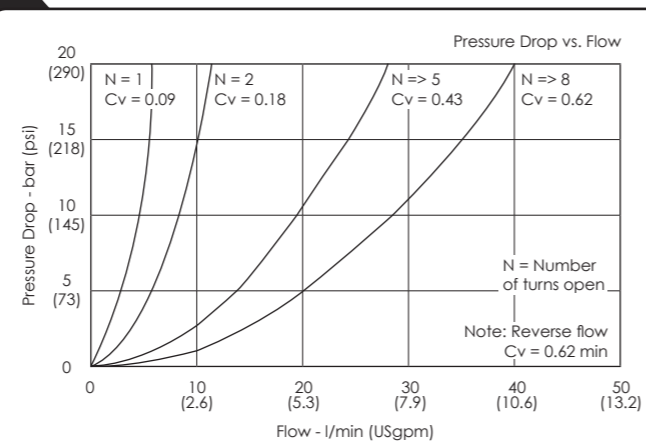

Typical performance based on water glycol

## Installation Diagram

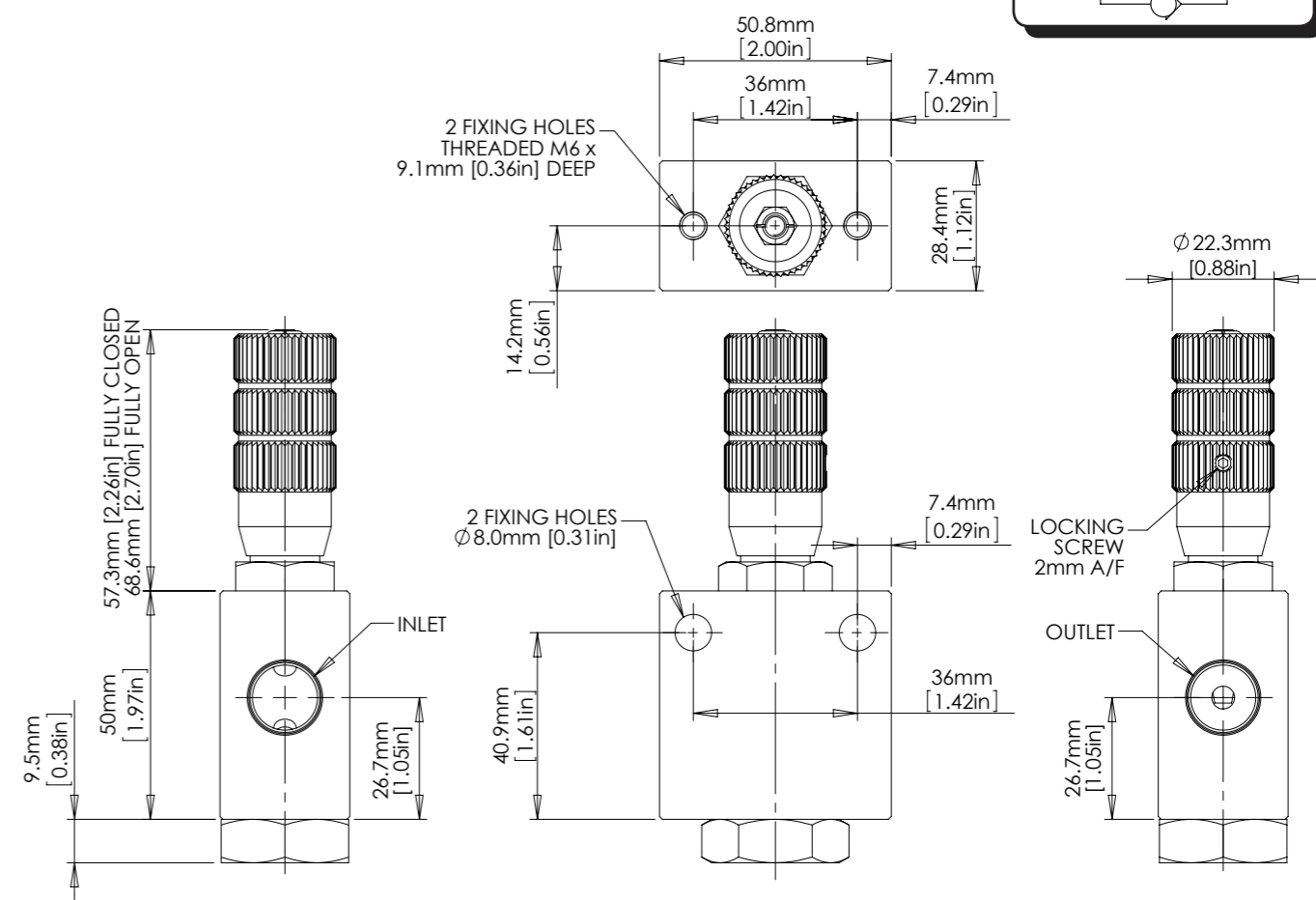

## Product Selector

### CMF37 P - NBR - 8K

VALVE TYPE	PORTING OPTIONS	SEAL OPTIONS	MAX WORKING PRESSURE
<b>CMF37</b>	<b>P</b> 3/8" BSPP female	Leave blank for Viton® seals -10°C to +120°C <b>NBR</b> Nitrile seals -30°C to +105°C	<b>8K</b> 552 bar (8,000 psi) Liquid
	<b>N</b> 3/8" NPT female	<b>EP</b> EPDM seals -45°C to +120°C	276 bar (4,000 psi) Gas
		<b>KLZ</b> Kalrez® seals -25°C to +120°C	
		<b>HNBR</b> Hydrogenated Nitrile seals -20°C to +120°C	

Repair and seal kits are available on request

For a seal kit add SK at the end of the model code and for a repair kit add RK

⚠ Exposure to high and low fluid temperatures will influence handle temperature. Operator safety must be considered.



Catalogue also available on digital media  
Visit our website for a full online search facility  
[www.bisvalves.co.uk](http://www.bisvalves.co.uk)



**BS VALVES**  
The Specifier's Catalogue

SOLENOID  
FLOW CONTROL  
3 PORT DIRECTIONAL CONTROL  
4 PORT DIRECTIONAL CONTROL  
CHECK AND SHUTTLE  
PILOT OPERATED CHECK  
RELIEF  
EXCESS FLOW  
FILTERS  
PRESSURE SENSING  
PUMPS  
ACTUATORS  
TECHNICAL DATA

# CMF50 METERING VALVE

1/2" UP TO 414 BAR 6,000 PSI

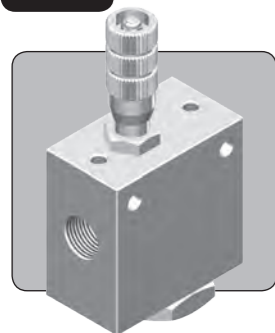

The CMF50 is a 1/2" nominal bore metering valve with a reverse free-flow check function. It provides metered flow in one direction, and free flow in the opposite direction, ideal for uni-directional speed control of a cylinder or actuator.

The valve can be adjusted manually after installation, and the setting can be locked.

Note that this is a flow control valve and is not intended to provide tight shut-off when closed.

- Metering valve with reverse free-flow check feature
- Micrometer style adjustment with engraved graduations
- Non-rotating valve stem with lockable adjustment
- Ideal for uni-directional speed control
- Stainless steel construction suitable for liquid or gas
- Can be panel mounted
- Suitable for use with air, nitrogen, sweet natural gas, mineral oils, water glycols and plain water
- Suitable for many other media. Contact us for advice
- Various porting options available
- Various seal options available on request

## Specifications

**BASIC MODEL NUMBER**

**CMF50**

**SYMBOL**

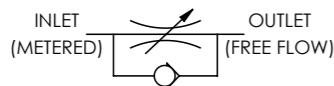

**MAX WORKING PRESSURE (LIQUID)** 414 bar (6,000 psi)

**MAX WORKING PRESSURE (GAS)** 207 bar (3,000 psi)

**CV (FLOW CAPACITY)** Up to 1.4  
See Typical Performance Graph

**FLUID** Liquids and Gases  
See materials section

**TEMPERATURE RANGE** See Product Selector opposite and Technical Data section

**PORT SIZE** 1/2"

**CHECK ELEMENT CRACKING PRESSURE** 0.1 - 0.3 bar (2 - 5 psi)

**WEIGHT** 2.0 kg (4.4 lb)

Specifications may change without notice

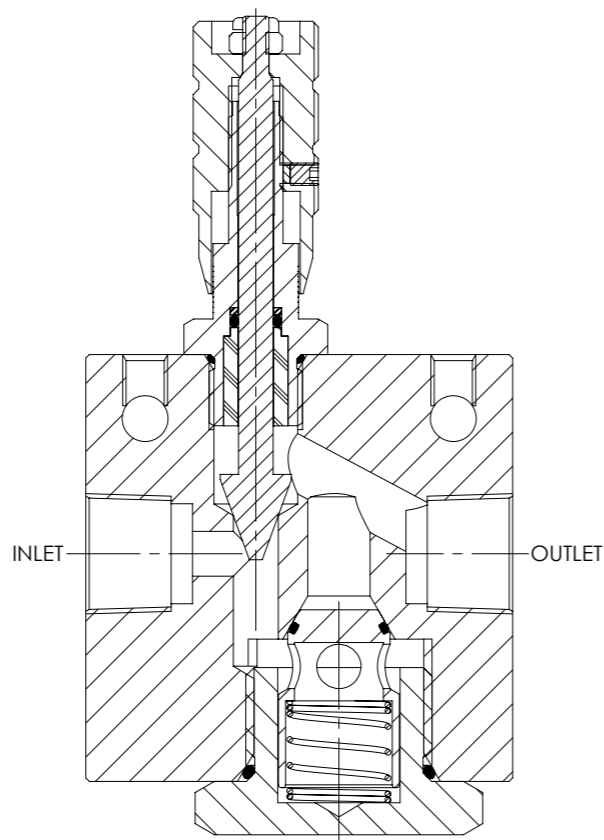

## Materials

Externally Exposed Parts: 316, 302 and 17-4 PH stainless steel.

Internally Wetted Parts: 316, 302 and 17-4 PH stainless steel, and acetal.

The standard valve is designed for use with air, nitrogen, sweet natural gas, mineral oil, water glycols and plain water, but may be used with a wide variety of media compatible with the materials of construction. Other material options are available and for further advice, please contact us.

⚠ The standard valve has Viton® seals. Further seal options are available via the Product Selector. Compatibility with the working fluid at the operating temperature must be considered.

## Typical Performance

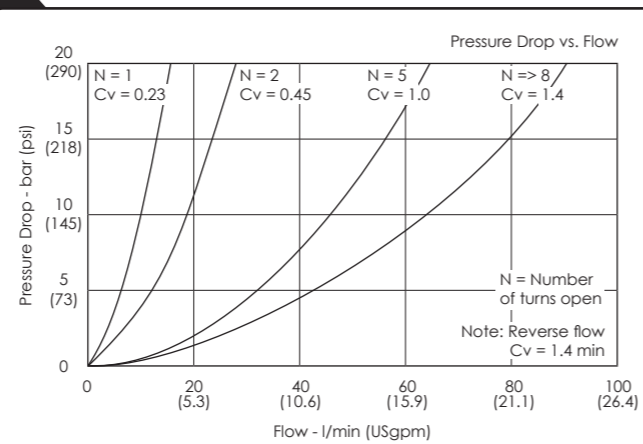

Typical performance based on water

## Installation Diagram

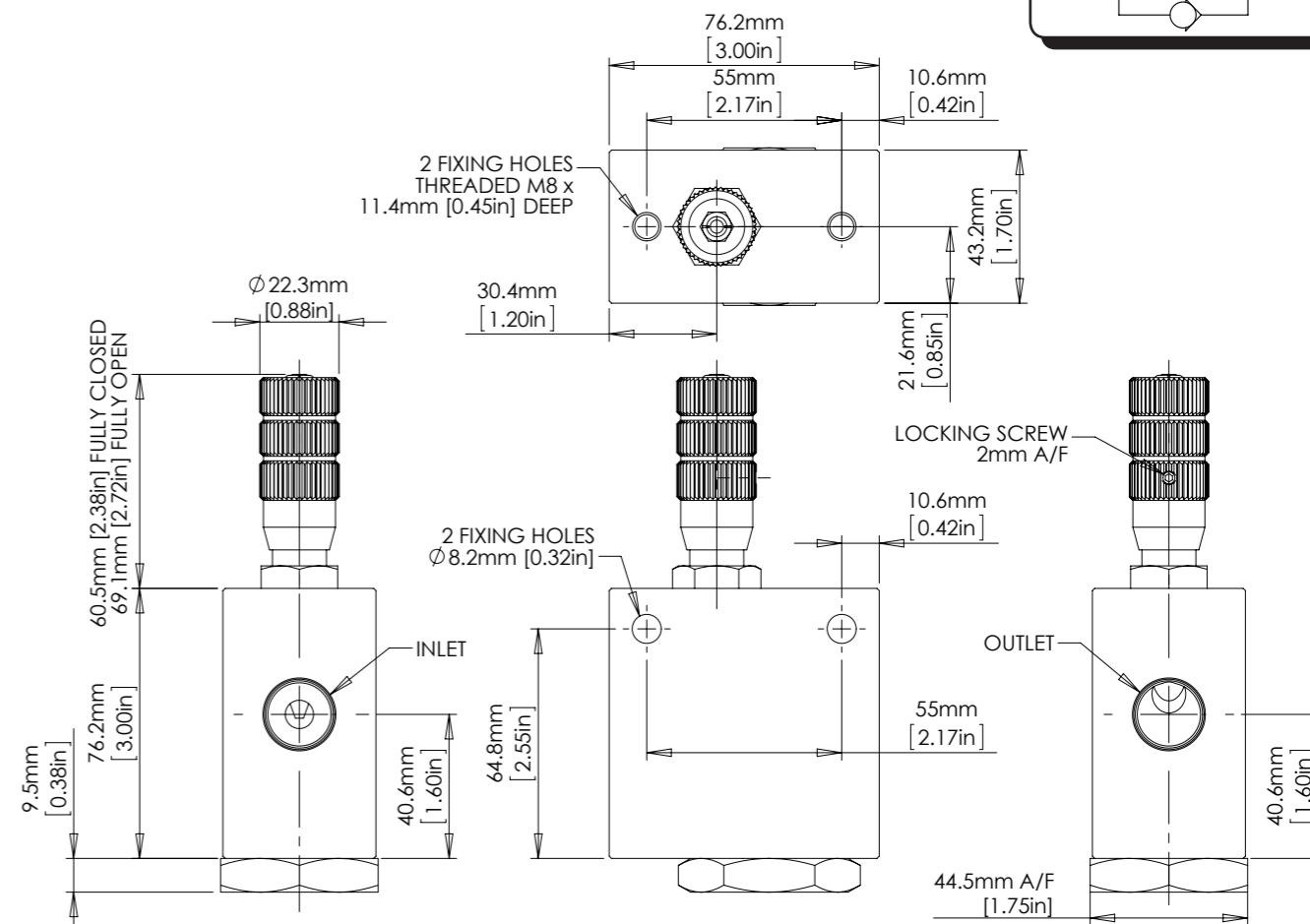

## Product Selector

### CMF50 P - NBR - 6K

VALVE TYPE	PORTING OPTIONS	SEAL OPTIONS	MAX WORKING PRESSURE
CMF50	<p><b>P</b> 1/2" BSPP female</p> <p><b>N</b> 1/2" NPT female</p>	<p>Leave blank for Viton® seals -10°C to +120°C</p> <p><b>NBR</b> Nitrile seals -30°C to +105°C</p> <p><b>EP</b> EPDM seals -45°C to +120°C</p> <p><b>KLZ</b> Kalrez® seals -25°C to +120°C</p> <p><b>HNBR</b> Hydrogenated Nitrile seals -20°C to +120°C</p> <p>Further seal options are available on request</p> <p>⚠ Exposure to high and low fluid temperatures will influence handle temperature. Operator safety must be considered.</p>	<p><b>6K</b> 414 bar (6,000 psi) Liquid</p> <p>207 bar (3,000 psi) Gas</p>

Repair and seal kits are available on request

For a seal kit add SK at the end of the model code and for a repair kit add RK



Catalogue also available on digital media  
Visit our website for a full online search facility  
[www.bisvalves.co.uk](http://www.bisvalves.co.uk)

**BS VALVES**  
The Specifier's Catalogue

SOLENOID  
FLOW CONTROL  
3 PORT DIRECTIONAL CONTROL  
4 PORT DIRECTIONAL CONTROL  
CHECK AND SHUTTLE  
PILOT OPERATED CHECK  
RELIEF  
EXCESS FLOW  
FILTERS  
PRESSURE SENSING  
PUMPS  
ACTUATORS  
TECHNICAL DATA

# CMF75 METERING VALVE

**3/4" UP TO 414 BAR 6,000 PSI**

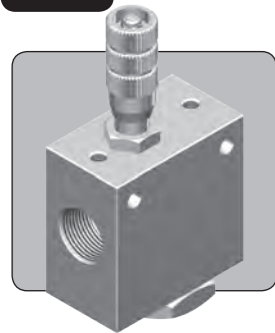

The CMF75 is a 3/4" nominal bore metering valve with a reverse free-flow check function. It provides metered flow in one direction, and free flow in the opposite direction, ideal for uni-directional speed control of a cylinder or actuator.

The valve can be adjusted manually after installation, and the setting can be locked.

Note that this is a flow control valve and is not intended to provide tight shut-off when closed.

- Metering valve with reverse free-flow check feature
- Micrometer style adjustment with engraved graduations
- Non-rotating valve stem with lockable adjustment
- Ideal for uni-directional speed control
- Stainless steel construction suitable for liquid or gas
- Can be panel mounted
- Suitable for use with air, nitrogen, sweet natural gas, mineral oils, water glycols and plain water
- Suitable for many other media. Contact us for advice
- Various porting options available
- Various seal options available on request

## Specifications

### BASIC MODEL NUMBER

**CMF75**

### SYMBOL

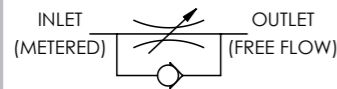

### MAX WORKING PRESSURE (LIQUID)

414 bar  
(6,000 psi)

### MAX WORKING PRESSURE (GAS)

207 bar  
(3,000 psi)

### CV (FLOW CAPACITY)

Up to 2.5  
See Typical Performance Graph

### FLUID

Liquids and Gases  
See materials section

### TEMPERATURE RANGE

See Product Selector opposite  
and Technical Data section

### PORT SIZE

3/4"

### CHECK ELEMENT CRACKING PRESSURE

0.4 - 0.7 bar  
(6 - 10 psi)

### WEIGHT

1.9 kg  
(4.3 lb)

Specifications may change without notice

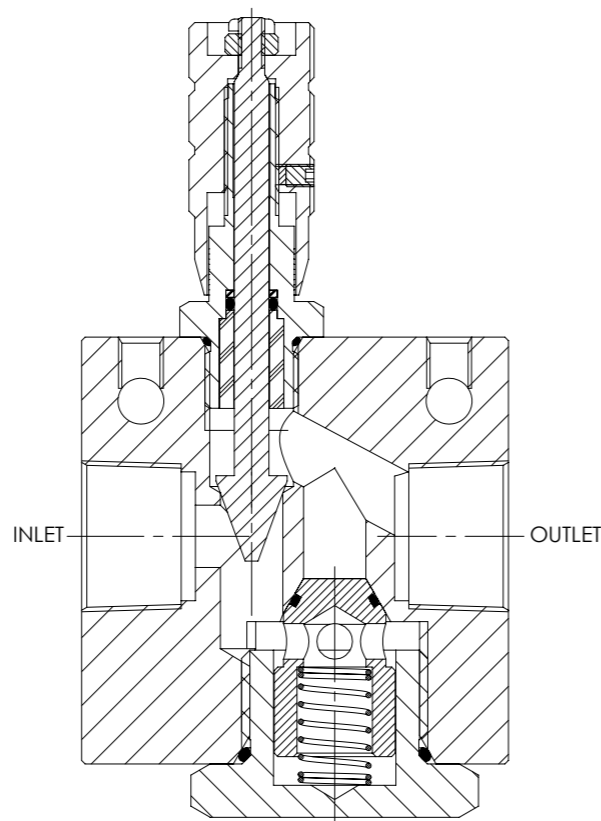

## Materials

Externally Exposed Parts: 316, 302 and 17-4 PH stainless steel.

Internally Wetted Parts: 316, 302 and 17-4 PH stainless steel, and acetal.

The standard valve is designed for use with air, nitrogen, sweet natural gas, mineral oil, water glycols and plain water, but may be used with a wide variety of media compatible with the materials of construction. Other material options are available and for further advice, please contact us.

⚠ The standard valve has Viton® seals. Further seal options are available via the Product Selector. Compatibility with the working fluid at the operating temperature must be considered.

## Typical Performance

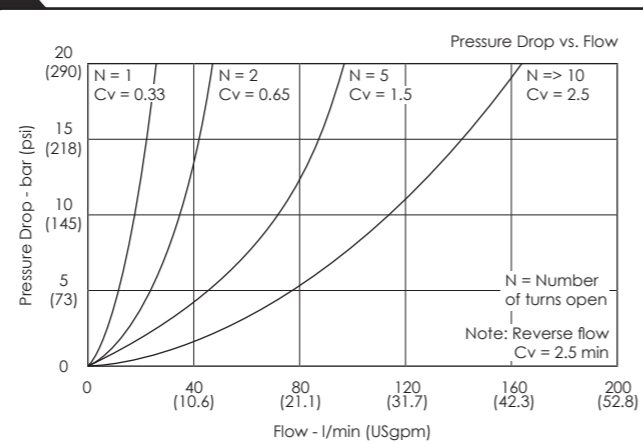

Typical performance based on water

## Installation Diagram

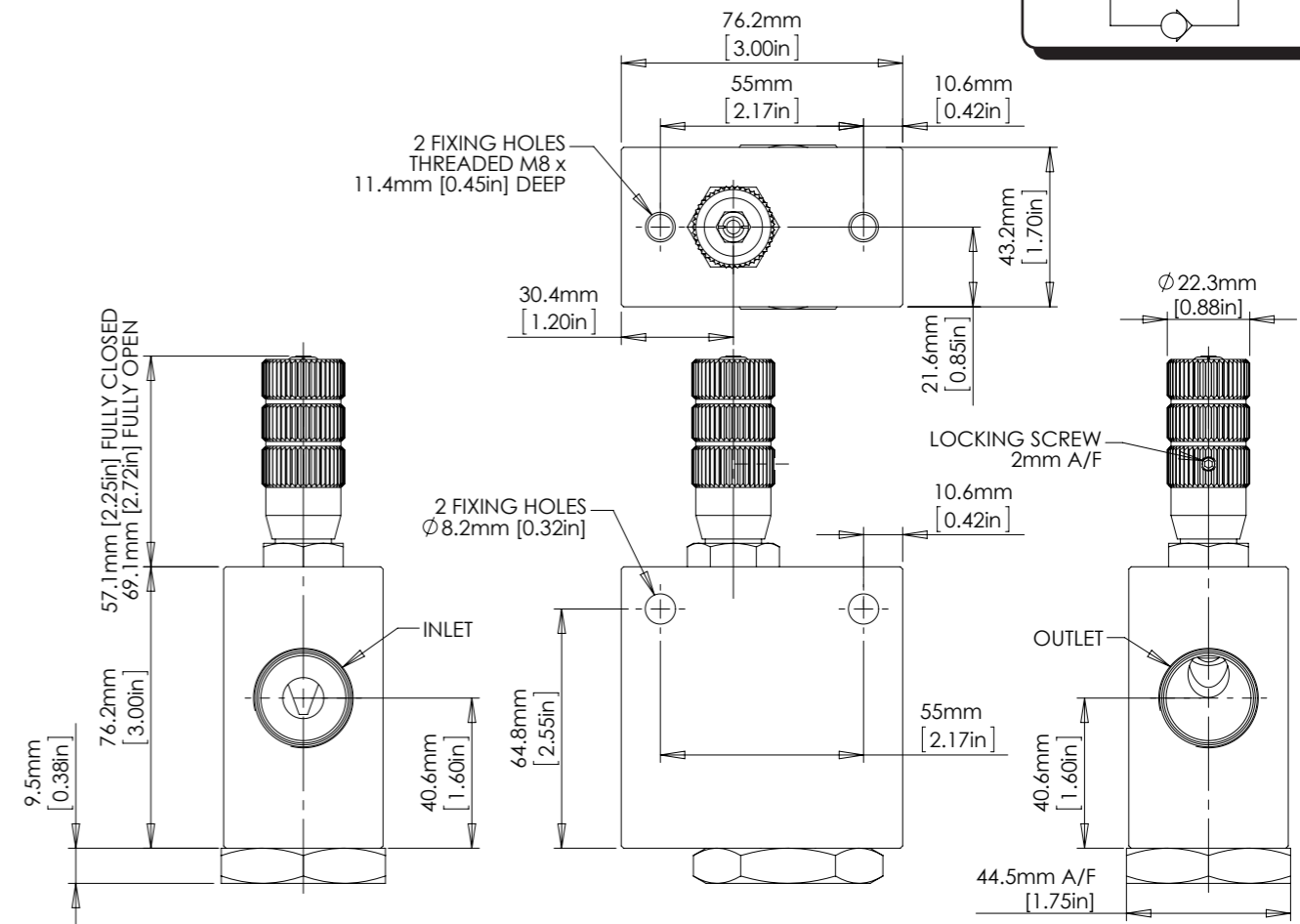

## Product Selector

### CMF75 P - NBR - 6K

VALVE TYPE	PORTING OPTIONS	SEAL OPTIONS	MAX WORKING PRESSURE
<b>CMF75</b>	<b>P</b> 3/4" BSPP female	Leave blank for Viton® seals -10°C to +120°C	<b>6K</b> 414 bar (6,000 psi) Liquid
	<b>N</b> 3/4" NPT female	<b>NBR</b> Nitrile seals -30°C to +105°C	207 bar (3,000 psi) Gas
		<b>EP</b> EPDM seals -45°C to +120°C	
		<b>KLZ</b> Kalrez® seals -25°C to +120°C	
		<b>HNBR</b> Hydrogenated Nitrile seals -20°C to +120°C	

Repair and seal kits are available on request

For a seal kit add SK at the end of the model code and for a repair kit add RK

⚠ Exposure to high and low fluid temperatures will influence handle temperature. Operator safety must be considered.



# -CMF100- METERING VALVE

1"

UP TO 414 BAR 6,000 PSI

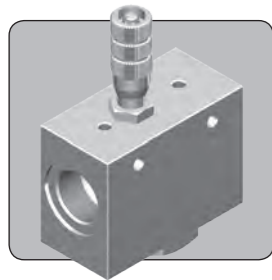

The CMF100 is a 1" nominal bore metering valve with a reverse free-flow check function. It provides metered flow in one direction, and free flow in the opposite direction, ideal for uni-directional speed control of a cylinder or actuator.

The valve can be adjusted manually after installation, and the setting can be locked.

Note that this is a flow control valve and is not intended to provide tight shut-off when closed.

- Metering valve with reverse free-flow check feature
- Micrometer style adjustment with engraved graduations
- Non-rotating valve stem with lockable adjustment
- Ideal for uni-directional speed control
- Stainless steel construction suitable for liquid or gas
- Can be panel mounted
- Suitable for use with air, nitrogen, sweet natural gas, mineral oils, water glycols and plain water
- Suitable for many other media. Contact us for advice
- Various porting options available
- Various seal options available on request

## Specifications

**BASIC MODEL NUMBER**

**CMF100**

**SYMBOL**

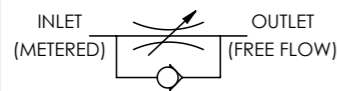

**MAX WORKING PRESSURE (LIQUID)**

414 bar  
(6,000 psi)

**MAX WORKING PRESSURE (GAS)**

207 bar  
(3,000 psi)

**CV (FLOW CAPACITY)**

Up to 2.5  
See Typical Performance Graph

**FLUID**

Liquids and Gases  
See materials section

**TEMPERATURE RANGE**

See Product Selector opposite  
and Technical Data section

**PORT SIZE**

1"

**CHECK ELEMENT CRACKING PRESSURE**

0.4 - 0.7 bar  
(6 - 10 psi)

**WEIGHT**

2.9 kg  
(6.4 lb)

Specifications may change without notice

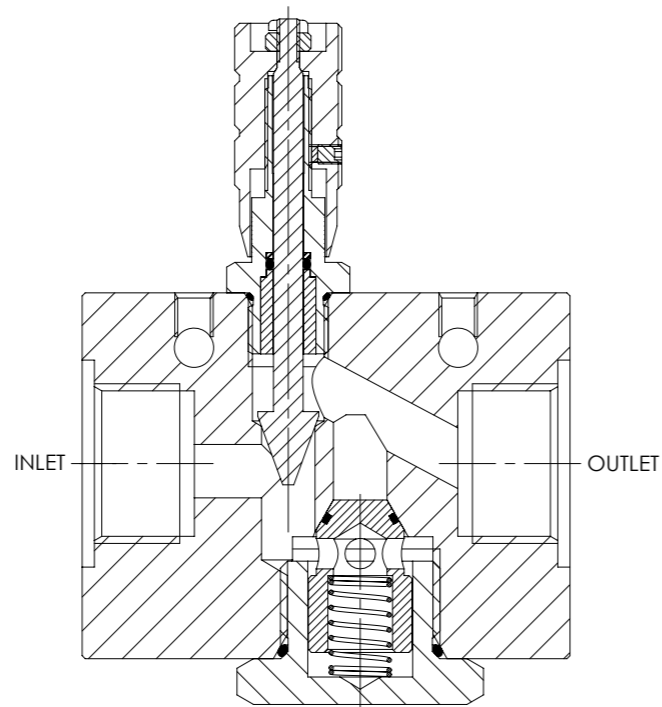

## Materials

Externally Exposed Parts: 316, 302 and 17-4 PH stainless steel.

Internally Wetted Parts: 316, 302 and 17-4 PH stainless steel, and acetal.

The standard valve is designed for use with air, nitrogen, sweet natural gas, mineral oil, water glycols and plain water, but may be used with a wide variety of media compatible with the materials of construction. Other material options are available and for further advice, please contact us.

⚠ The standard valve has Viton® seals. Further seal options are available via the Product Selector. Compatibility with the working fluid at the operating temperature must be considered.

## Typical Performance

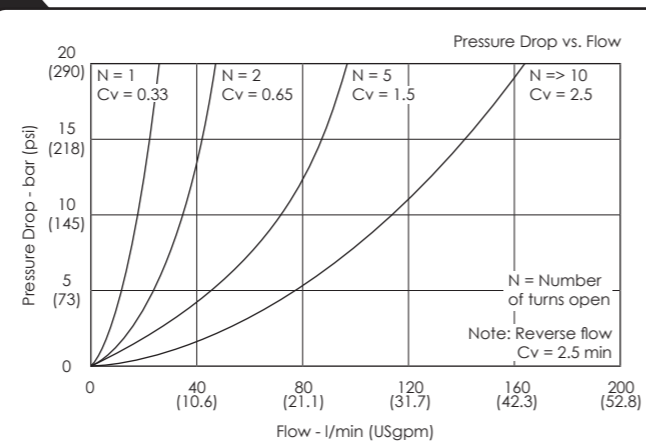

Typical performance based on water

## Installation Diagram

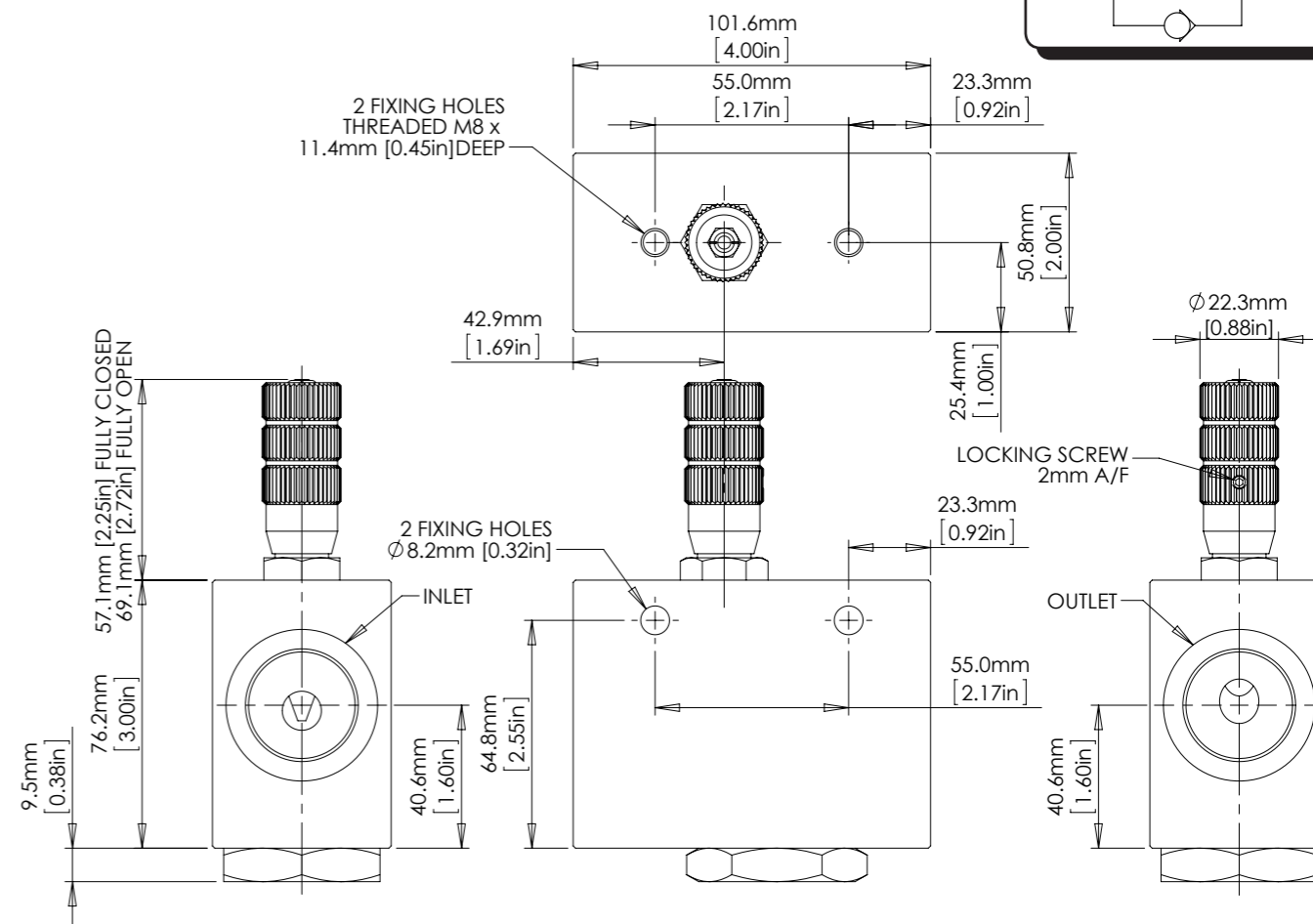

## Product Selector

### CMF100 P - NBR - 6K

VALVE TYPE	PORTING OPTIONS	SEAL OPTIONS	MAX WORKING PRESSURE
CMF100	<b>P</b> 1" BSPF female  <b>N</b> 1" NPT female	Leave blank for Viton® seals -10°C to +120°C <b>NBR</b> Nitrile seals -30°C to +105°C <b>EP</b> EPDM seals -45°C to +120°C <b>KLZ</b> Kalrez® seals -25°C to +120°C <b>HNBR</b> Hydrogenated Nitrile seals -20°C to +120°C Further seal options are available on request ⚠ Exposure to high and low fluid temperatures will influence handle temperature. Operator safety must be considered.	<b>6K</b> 414 bar (6,000 psi) Liquid  207 bar (3,000 psi) Gas

Repair and seal kits are available on request  
For a seal kit add SK at the end of the model code and for a repair kit add RK



SOLENOID  
FLOW CONTROL  
3 PORT DIRECTIONAL CONTROL  
4 PORT DIRECTIONAL CONTROL  
CHECK AND SHUTTLE  
PILOT OPERATED CHECK  
RELIEF  
EXCESS FLOW  
FILTERS  
PRESSURE SENSING  
PUMPS  
ACTUATORS  
TECHNICAL DATA



# IMC25 METERING VALVE

**1/4" UP TO 552 BAR 8,000 PSI**

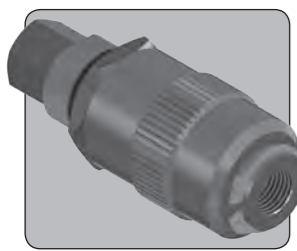

The IMC25 is a 1/4" nominal bore metering valve with a reverse free-flow check function. It provides metered flow in one direction, and free flow in the opposite direction. It is ideal for uni-directional speed control of a cylinder or actuator. The valve may also be referred to as a flow control valve.

Note that this valve does not provide tight shut-off.

- Metering valve with reverse free-flow check feature
- Inline design with barrel style adjustment offers maximum space efficiency
- Lockable adjustment
- Ideal for uni-directional speed control
- Stainless steel construction
- Variants can be tailor-made to suit specific metering characteristics. Contact us for advice
- Suitable for use with mineral oils, water glycols and plain water
- Suitable for many other media, contact us for advice
- Various porting options available
- Various seal options available

## Specifications

**BASIC MODEL NUMBER**

**IMC25**

**SYMBOL**

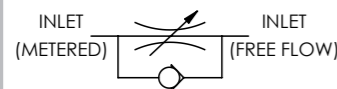

**MAX WORKING PRESSURE (LIQUID)**

552 bar  
(8,000 psi)

**CV (FLOW CAPACITY)**

Up to 0.55 (Metered)  
1.1 (Free flow)  
*See Typical Performance Graph*

**FLUID**

Liquids only  
*See materials section*

**TEMPERATURE RANGE**

*See Product Selector opposite and Technical Data section*

**PORT SIZE**

1/4"

**CHECK ELEMENT CRACKING PRESSURE**

0.1 - 0.3 bar  
(2 - 5 psi)

**WEIGHT**

0.45 kg  
(1.0 lb)

*Specifications may change without notice*

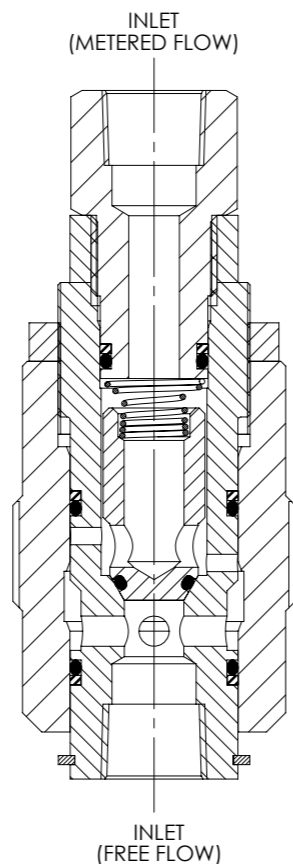

## Materials

Externally Exposed Parts: 316 Stainless Steel with a 400 Series Stainless Steel adjustment stop circlip.

Internally Wetted Parts: 316 and 302 Stainless Steel and Acetal.

The standard valve is designed for use with mineral oils, water glycols, plain water and may also be used with a wide variety of media compatible with the materials of construction. Please contact us for advice when different construction materials are required.

**⚠** The standard valve has Viton® seals. Further seal options are available via the Product Selector. Compatibility with the working fluid at the operating temperature must be considered.

## Typical Performance

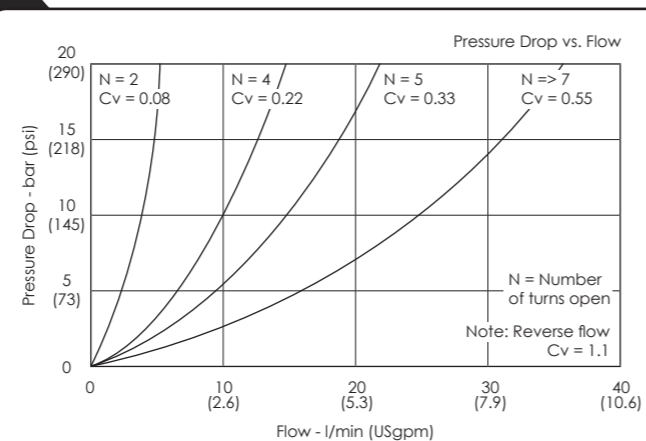

*Typical performance based on water*

## Installation Diagram

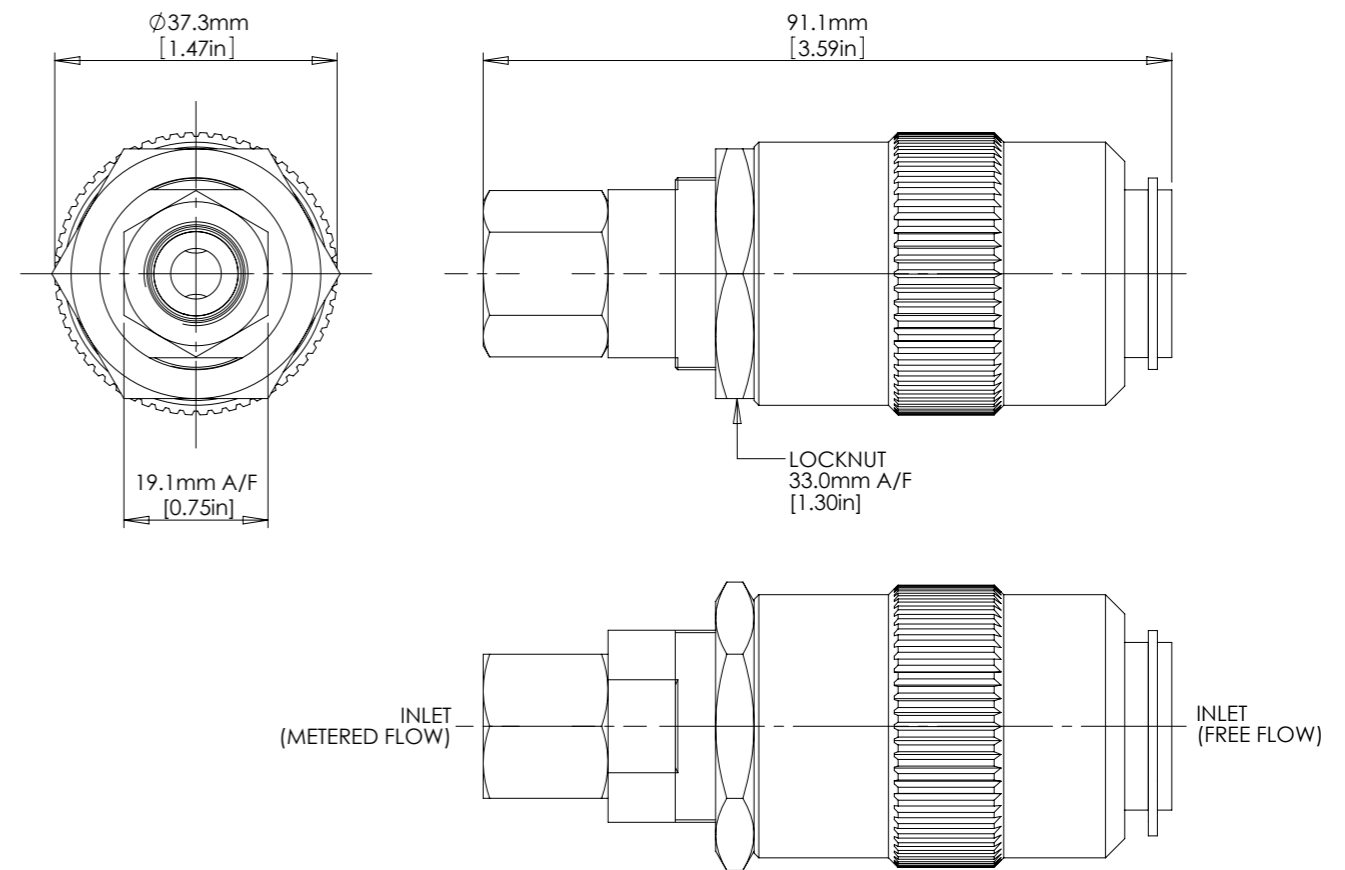

## Product Selector

### IMC25 P - NBR - 8K

VALVE TYPE	PORTING OPTIONS	SEAL OPTIONS	MAX WORKING PRESSURE
<b>IMC25</b>	<b>P</b> 1/4" BSPP female	Leave blank for Viton® seals -10°C to +120°C <b>NBR</b> Nitrile seals -30°C to +105°C	<b>8K</b> 552 bar (8,000 psi) Liquid
	<b>N</b> 1/4" NPT female	<b>EP</b> EPDM seals -45°C to +120°C	
		<b>KLZ</b> Kalrez® seals -25°C to +120°C	
		<b>HNBR</b> Hydrogenated Nitrile seals -20°C to +120°C	

*Repair and seal kits are available on request*

*For a seal kit add SK at the end of the model code and for a repair kit add RK*

**⚠** Exposure to high and low fluid temperatures will influence handle temperature. Operator safety must be considered.



# IMC37 METERING VALVE

**3/8" UP TO 552 BAR 8,000 PSI**

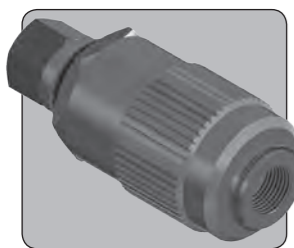

The IMC37 is a 3/8" nominal bore metering valve with a reverse free-flow check function. It provides metered flow in one direction, and free flow in the opposite direction. It is ideal for uni-directional speed control of a cylinder or actuator. The valve may also be referred to as a flow control valve.

Note that this valve does not provide tight shut-off.

- Metering valve with reverse free-flow check feature
- Inline design with barrel style adjustment offers maximum space efficiency
- Lockable adjustment
- Ideal for uni-directional speed control
- Stainless steel construction
- Variants can be tailor-made to suit specific metering characteristics. Contact us for advice
- Suitable for use with mineral oils, water glycols and plain water
- Suitable for many other media, contact us for advice
- Various porting options available
- Various seal options available

## Specifications

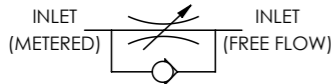
<b>BASIC MODEL NUMBER</b>	<b>IMC37</b>
<b>SYMBOL</b>	
<b>MAX WORKING PRESSURE (LIQUID)</b>	552 bar (8,000 psi)
<b>CV (FLOW CAPACITY)</b>	Up to 0.72 (Metered) 1.45 (Free flow) <i>See Typical Performance Graph</i>
<b>FLUID</b>	Liquids only <i>See materials section</i>
<b>TEMPERATURE RANGE</b>	<i>See Product Selector opposite and Technical Data section</i>
<b>PORT SIZE</b>	3/8"
<b>CHECK ELEMENT CRACKING PRESSURE</b>	0.1 - 0.3 bar (2 - 5 psi)
<b>WEIGHT</b>	0.75 kg (1.7 lb)

Specifications may change without notice

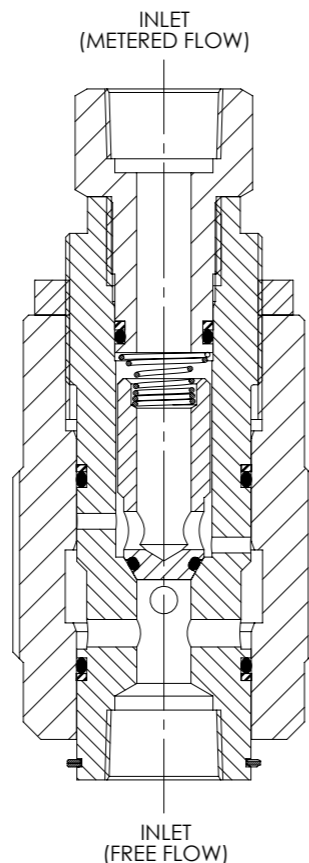

## Materials

Externally Exposed Parts: 316 Stainless Steel with a 302 Stainless Steel adjustment stop circlip.

Internally Wetted Parts: 316 and 302 Stainless Steel and Acetal.

The standard valve is designed for use with mineral oils, water glycols, plain water and may also be used with a wide variety of media compatible with the materials of construction. Please contact us for advice when different construction materials are required.

**⚠** The standard valve has Viton® seals. Further seal options are available via the Product Selector. Compatibility with the working fluid at the operating temperature must be considered.

## Typical Performance

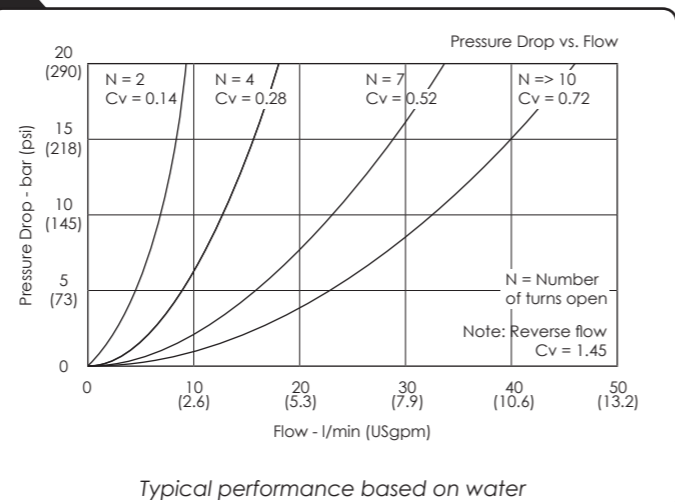

## Installation Diagram

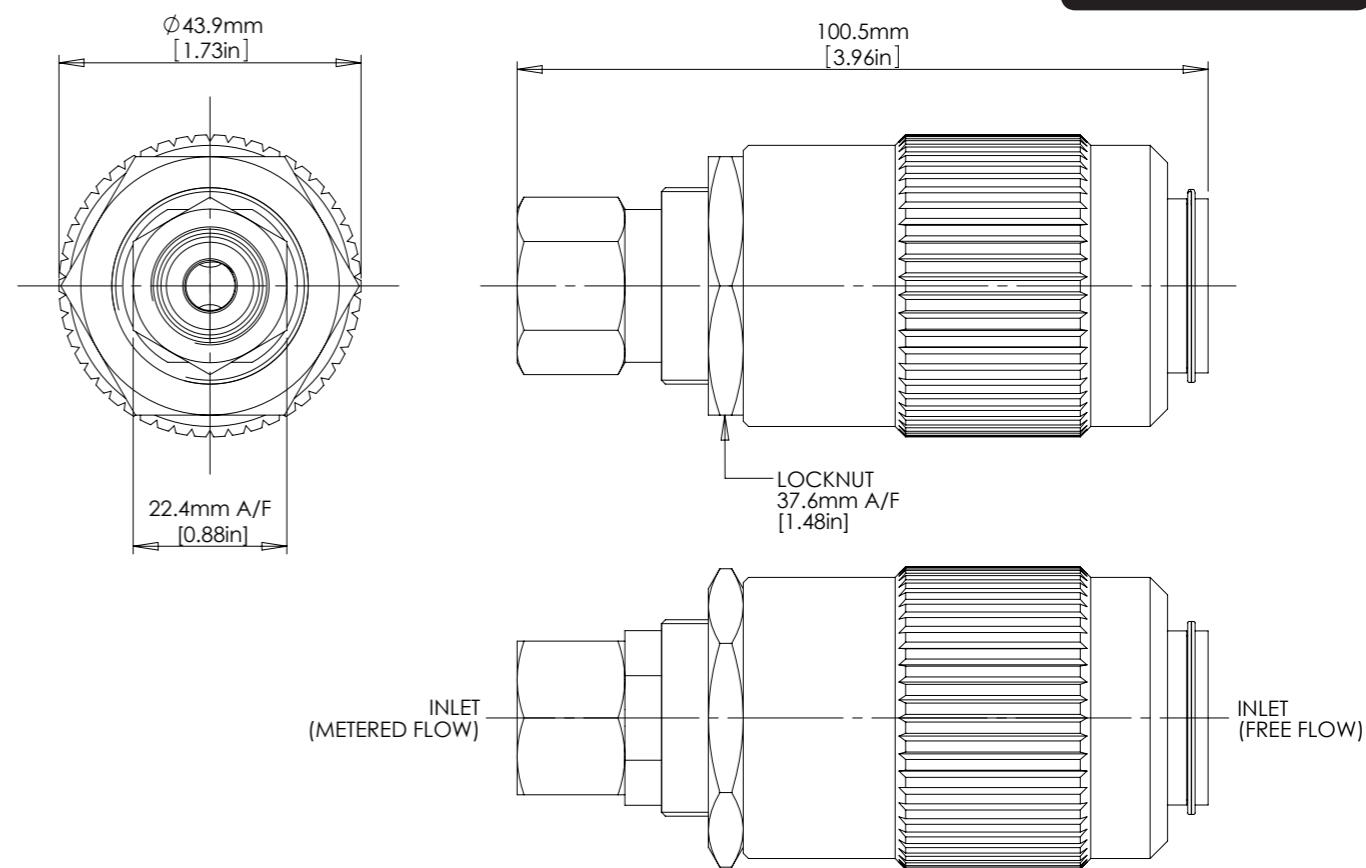

## Product Selector

IMC37 P - NBR - 8K			
VALVE TYPE	PORTING OPTIONS	SEAL OPTIONS	MAX WORKING PRESSURE
IMC37	<p><b>P</b> 3/8" BSPP female</p> <p><b>N</b> 3/8" NPT female</p>	<p>Leave blank for Viton® seals -10°C to +120°C</p> <p><b>NBR</b> Nitrile seals -30°C to +105°C</p> <p><b>EP</b> EPDM seals -45°C to +120°C</p> <p><b>KLZ</b> Kalrez® seals -25°C to +120°C</p> <p><b>HNBR</b> Hydrogenated Nitrile seals -20°C to +120°C</p> <p>Further seal options are available on request</p> <p><b>⚠</b> Exposure to high and low fluid temperatures will influence handle temperature. Operator safety must be considered.</p>	<p><b>8K</b> 552 bar (8,000 psi) Liquid</p>
<p>Repair and seal kits are available on request</p> <p>For a seal kit add SK at the end of the model code and for a repair kit add RK</p>			



Catalogue also available on digital media  
Visit our website for a full online search facility  
[www.bisvalves.co.uk](http://www.bisvalves.co.uk)



**BS VALVES**  
The Specifier's Catalogue

SOLENOID  
FLOW CONTROL  
3 PORT DIRECTIONAL CONTROL  
4 PORT DIRECTIONAL CONTROL  
CHECK AND SHUTTLE  
PILOT OPERATED CHECK  
RELIEF  
EXCESS FLOW  
FILTERS  
PRESSURE SENSING  
PUMPS  
ACTUATORS  
TECHNICAL DATA

# IMC50 METERING VALVE

**1/2" UP TO 552 BAR 8,000 PSI**

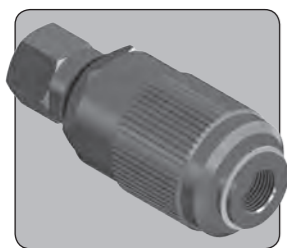

The IMC50 is a 1/2" nominal bore metering valve with a reverse free-flow check function. It provides metered flow in one direction, and free flow in the opposite direction. It is ideal for uni-directional speed control of a cylinder or actuator. The valve may also be referred to as a flow control valve.

Note that this valve does not provide tight shut-off.

- Metering valve with reverse free-flow check feature
- Inline design with barrel style adjustment offers maximum space efficiency
- Lockable adjustment
- Ideal for uni-directional speed control
- Stainless steel construction
- Variants can be tailor-made to suit specific metering characteristics. Contact us for advice
- Suitable for use with mineral oils, water glycols and plain water
- Suitable for many other media, contact us for advice
- Various porting options available
- Various seal options available

## Specifications

**BASIC MODEL NUMBER**

**IMC50**

**SYMBOL**

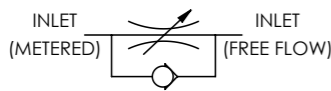

**MAX WORKING PRESSURE (LIQUID)**

552 bar  
(8,000 psi)

**CV (FLOW CAPACITY)**

Up to 1.2 (Metered)  
3.0 (Free flow)  
*See Typical Performance Graph*

**FLUID**

Liquids only  
*See materials section*

**TEMPERATURE RANGE**

*See Product Selector opposite and Technical Data section*

**PORT SIZE**

1/2"

**CHECK ELEMENT CRACKING PRESSURE**

0.1 - 0.3 bar  
(2 - 5 psi)

**WEIGHT**

1.25 kg  
(2.8 lb)

*Specifications may change without notice*

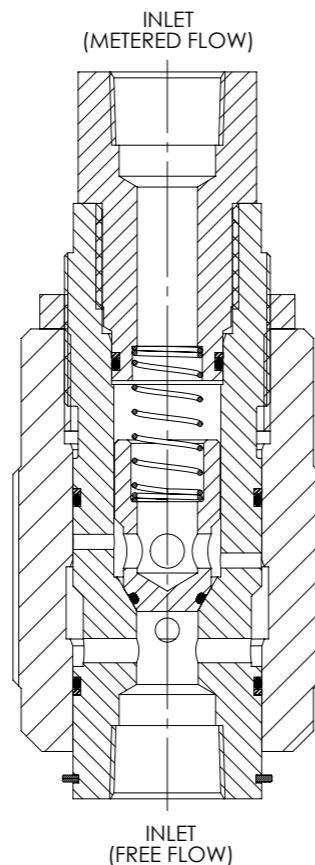

## Materials

Externally Exposed Parts: 316 Stainless Steel with a 302 Series Stainless Steel adjustment stop circlip.

Internally Wetted Parts: 316 and 302 Stainless Steel and Acetal.

The standard valve is designed for use with mineral oils, water glycols, plain water and may also be used with a wide variety of media compatible with the materials of construction. Please contact us for advice when different construction materials are required.

⚠ The standard valve has Viton® seals. Further seal options are available via the Product Selector. Compatibility with the working fluid at the operating temperature must be considered.

## Typical Performance

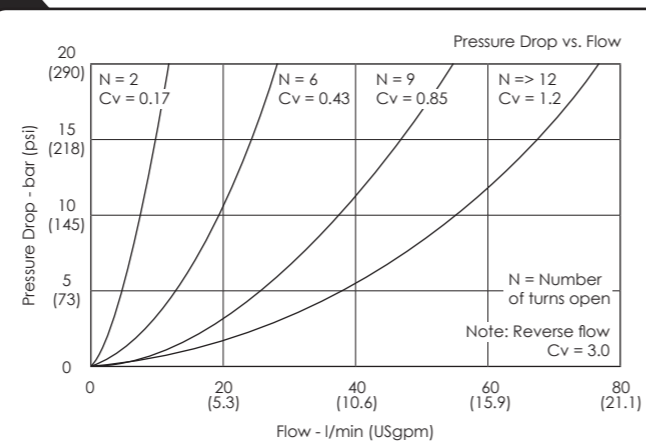

Typical performance based on water

## Installation Diagram

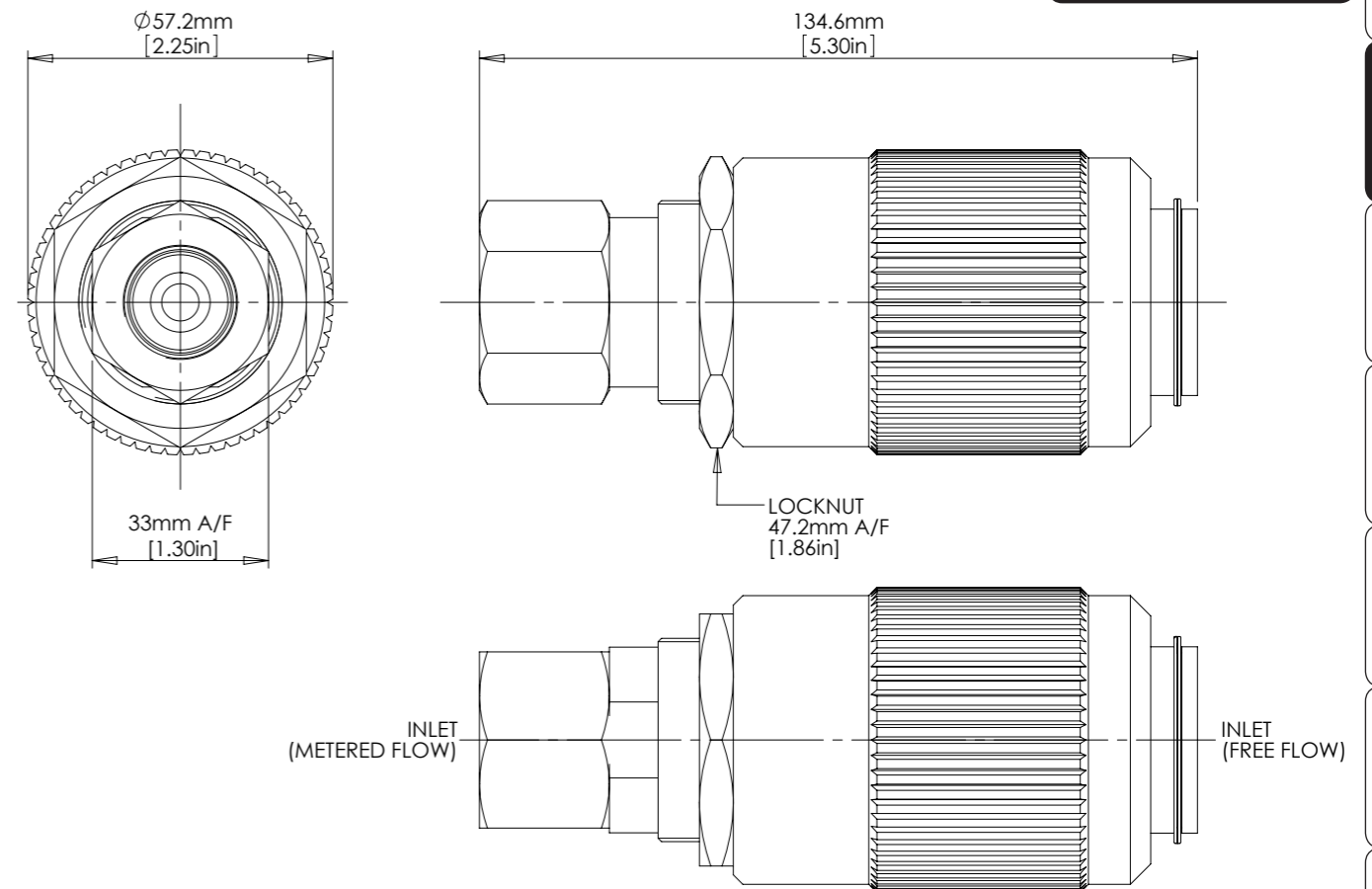

## Product Selector

### IMC50 P - NBR - 8K

VALVE TYPE	PORTING OPTIONS	SEAL OPTIONS	MAX WORKING PRESSURE
<b>IMC50</b>	<p><b>P</b> 1/2" BSPP female</p> <p><b>N</b> 1/2" NPT female</p>	<p>Leave blank for Viton® seals -10°C to +120°C</p> <p><b>NBR</b> Nitrile seals -30°C to +105°C</p> <p><b>EP</b> EPDM seals -45°C to +120°C</p> <p><b>KLZ</b> Kalrez® seals -25°C to +120°C</p> <p><b>HNBR</b> Hydrogenated Nitrile seals -20°C to +120°C</p> <p><i>Further seal options are available on request</i></p> <p>⚠ Exposure to high and low fluid temperatures will influence handle temperature. Operator safety must be considered.</p>	<p><b>8K</b> 552 bar (8,000 psi) Liquid</p>

Repair and seal kits are available on request  
For a seal kit add SK at the end of the model code and for a repair kit add RK



Catalogue also available on digital media  
Visit our website for a full online search facility  
[www.bisvalves.co.uk](http://www.bisvalves.co.uk)

SOLENOID  
FLOW CONTROL  
3 PORT DIRECTIONAL CONTROL  
4 PORT DIRECTIONAL CONTROL  
CHECK AND SHUTTLE  
PILOT OPERATED CHECK  
RELIEF  
EXCESS FLOW  
FILTERS  
PRESSURE SENSING  
PUMPS  
ACTUATORS  
TECHNICAL DATA

# PCFR50

## FLOW REGULATOR

1/2" 3/8"

UP TO 690 BAR  
10,000 PSI

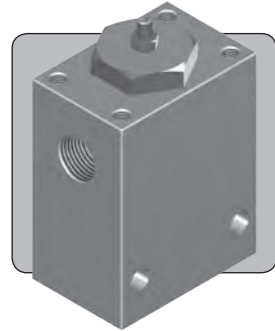

The PCFR50 is a pressure compensated flow control valve. Unlike a standard metering valve, the PCFR50 provides a relatively constant flow in one direction, regardless of the pressure differential across the valve, and is ideal for providing constant speed control of functions that have variable loads.

In reverse, the valve will open to allow non-metered reverse

flow once a differential pressure of approximately 7 bar (102 psi) or 2 bar (29 psi) for LF versions is exceeded, and below this pressure will provide non-pressure compensated metered flow. This valve does not provide tight shut-off when closed.

- Pressure compensated flow control valve
- Adjustable flow setting with locking feature
- Ideal for uni-directional speed control with variable loads or supply pressures
- Stainless steel construction
- Suitable for use with mineral oils and water glycols and many other media, contact us for advice
- Subsea variant available, contact us for advice
- Various porting options available, including a cartridge version for use in manifolds

### Specifications

**BASIC MODEL NUMBER**

**PCFR50**

**SYMBOL**

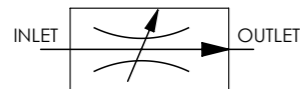

**MAX WORKING PRESSURE (LIQUID)**

690 bar  
(10,000 psi)

**MAXIMUM DIFFERENTIAL PRESSURE**

414 bar  
(6,000 psi)

**MINIMUM DIFFERENTIAL PRESSURE**

15 bar  
(218 psi)  
*When operated below this differential pressure, flow rate will not be pressure compensated*

**REGULATED FLOW SETTING RANGE**

5 - 45 l/min (1.3 - 11.9 USgpm)  
*For lower flows, see LF version in Product Selector opposite*

**FLUID**

Liquids only  
*See materials section*

**TEMPERATURE RANGE**

*See Product Selector opposite and Technical Data section*

**PORT SIZE**

1/2" or 3/8"  
*See Product Selector opposite*

**WEIGHT**

**Standard** 2.8 kg (6.2 lb)  
**PCFR50C** 0.35 kg (0.8 lb)

*Specifications may change without notice*

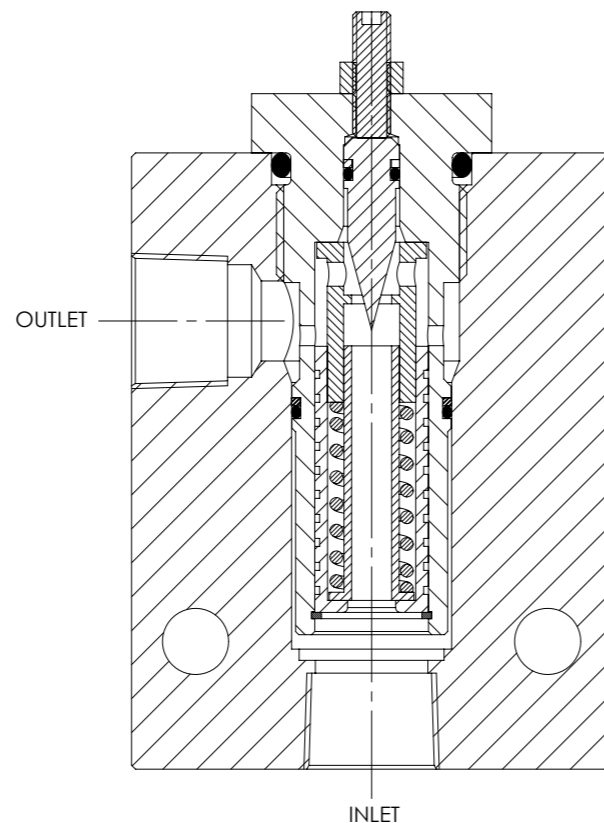

### Materials

Externally Exposed Parts: 316 and 304 stainless steel.  
Internally Wetted Parts: 316, 302, 431 and 440C stainless steel and acetal for the standard valve. 316, 302, 17-4 PH, acetal and aluminium bronze for the water duty version.

The standard valve is designed for use with non-corrosive liquids only, such as mineral oil and water glycol. A water duty version is available for use in plain water systems. Contact us for advice where use with more corrosive fluids is required.

**!** The standard valve has Viton® seals. Further seal options are available via the Product Selector. Compatibility with the working fluid at the operating temperature must be considered.

### Typical Performance

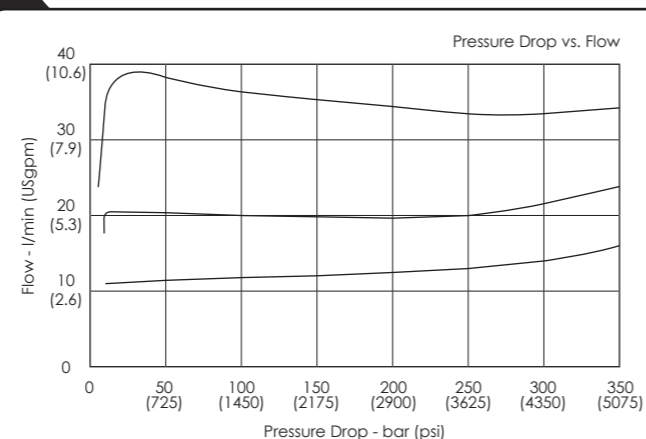

*Typical performance based on water*

### Installation Diagram

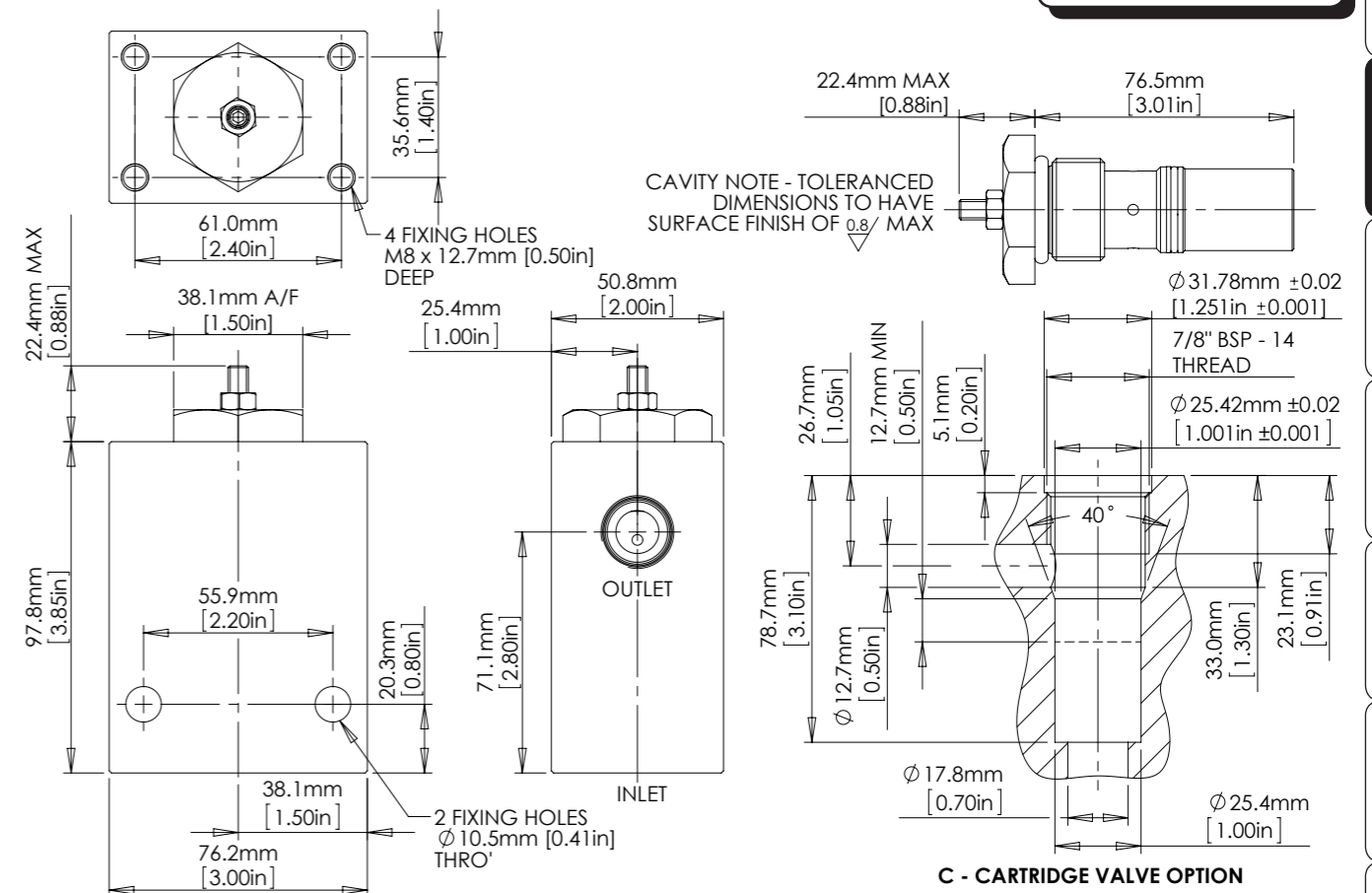

### Product Selector

#### PCFR50 P - LF - NBR - 10K

VALVE TYPE	PORTING OPTIONS	VALVE OPTIONS	SEAL OPTIONS	MAX WORKING PRESSURE
PCFR50	<b>P</b> 1/2" BSPF female	<b>LF</b> Low flow 2 - 15 L/Min (0.5 - 4.0 USgpm)	<b>NBR</b> Nitrile seals -30°C to +105°C	<b>10K</b> 690 bar (10,000 psi) Liquid
	<b>N</b> 1/2" NPT female	<b>WD</b> Water Duty	<b>EP</b> EPDM seals -45°C to +120°C <i>Only available with the WD option</i>	
	<b>/37P</b> 3/8" BSPF female	<i>Any combination of options is allowable</i>	<b>KLZ</b> Kalrez® seals -25°C to +120°C	
	<b>/37N</b> 3/8" NPT female		<b>HNBR</b> Hydrogenated Nitrile seals -20°C to +120°C	
	<b>C</b> Cartridge valve		<i>Further seal options are available on request</i>	

*Repair and seal kits are available on request*

*For a seal kit add SK at the end of the model code and for a repair kit add RK*



Catalogue also available on digital media  
Visit our website for a full online search facility  
[www.bisvalves.co.uk](http://www.bisvalves.co.uk)



**BS VALVES**  
The Specifier's Catalogue

SOLENOID  
FLOW CONTROL  
3 PORT DIRECTIONAL CONTROL  
4 PORT DIRECTIONAL CONTROL  
CHECK AND SHUTTLE  
PILOT OPERATED CHECK  
RELIEF  
EXCESS FLOW  
FILTERS  
PRESSURE SENSING  
PUMPS  
ACTUATORS  
TECHNICAL DATA



# Terms and Conditions

BIS Valves Ltd., Units 17-23 Kingfisher Park, West Moors, Wimborne, Dorset, BH21 6US, United Kingdom

## TERMS AND CONDITIONS Rev: 3

### 1. INTERPRETATION

1.1 Definitions. In these Conditions, the following definitions apply:

- 'Business Day' means a day (other than a Saturday, Sunday or public holiday) when banks in London are open for business.
- 'Buyer' means the person or firm who accepts a quotation of the Seller for the sale of the goods or whose order for the goods is accepted by the Seller.
- 'Conditions' means the standard terms and conditions of sale set out in this document as amended from time to time and (unless the context otherwise requires) includes any special terms and conditions agreed in writing between the Buyer and the Seller.
- 'Contract' means the contract between the Seller and the Buyer for the sale and purchase of the Goods in accordance with these conditions.
- 'Force Majeure' Event has the meaning given in clause 10.
- 'Goods' means the goods (including any instalment of the goods or any parts for them) which the Seller is to supply in accordance with these Conditions.
- 'Order' means the Buyer's Order for the Goods.
- 'Seller' means BIS Valves Limited (registered in England and Wales with Company Number 826821)
- 'Specification' means any specification for the Goods, including any related plans and drawings that are agreed in writing by the Buyer and the Seller.
- 'Writing' includes facsimile transmission email and any comparable means of communication.

1.2 Construction. In these Conditions, the following rules apply:

- 1.2.1 The headings in these Conditions are for convenience only and shall not affect their interpretation.
- 1.2.2 A **person** includes a natural person, corporate or unincorporated body (whether or not having a separate legal personality).
- 1.2.3 A reference to a party includes its personal representatives, successors or permitted assigns.
- 1.2.4 A reference to a statute or statutory provision is a reference to such statute or provision as amended or re-enacted. A reference to a statute or statutory provision includes any subordinate legislation made under that statute or statutory provision, as amended or re-enacted.
- 1.2.5 Any phrase introduced by the terms **including, include, in particular** or any similar expression shall be construed as illustrative and shall not limit the sense of the words preceding those terms.

### 2. BASIS OF THE CONTRACT

- 2.1 These Conditions apply to the Contract to the exclusion of any other terms that the Buyer seeks to impose or incorporate, or which are implied by trade, custom, practice or course of dealing.
- 2.2 The Order constitutes an offer by the Buyer to purchase the Goods in accordance with these Conditions. The Buyer is responsible for ensuring that the terms of the Order are complete and accurate and for giving the Seller any and all necessary information relating to the Goods within a reasonable time to enable the Seller to perform the Contract in accordance with its terms.
- 2.3 No variation to these Conditions shall be binding unless agreed in writing between the authorised representatives of the Buyer and the Seller.
- 2.4 The Contract constitutes the entire agreement between the parties. The Buyer acknowledges that it has not relied on any statement, promise or representation made or given by or on behalf of the Seller which is not set out in the Contract.
- 2.5 Any samples, drawings, descriptive matter, or advertising produced by the Seller and any descriptions or illustrations contained in the Seller's catalogues or brochures are produced for the sole purpose of giving an approximate idea of the Goods described in them. They shall not form part of the Contract or have any contractual force.
- 2.6 A quotation for the Goods given by the Seller shall not constitute an offer and shall only be valid for a period of 90 days from its date of issue.

### 3. ORDERS AND SPECIFICATIONS

- 3.1 No Order submitted by the Buyer shall be deemed to be accepted by the Seller unless and until confirmed in writing by the Seller's authorised representative.
- 3.2 The quantity, quality and description of and any Specification for the Goods shall be those set out in the Seller's quotation (if accepted by the Buyer) or the Buyer's order (if accepted by the Seller).
- 3.3 To the extent that the Goods are to be manufactured in accordance with a Specification supplied by the Buyer, the Buyer shall indemnify the Seller against all liabilities, costs, expenses, damages and losses (including any direct, indirect or consequential losses, loss of profit, loss of reputation and all interest, penalties and legal and other professional costs and expenses) suffered or incurred by the Seller in connection with any claim made against the Seller for actual or alleged infringement of any third party's intellectual property rights arising out of or in connection with the Seller's use of the Specification. This clause 3 shall survive termination of the Contract.
- 3.4 The Seller reserves the right to amend the Specification of the Goods if required by any applicable statutory or regulatory requirements.
- 3.5 No Order which has been accepted by the Seller may be cancelled by the Buyer except with the agreement in writing of the Seller and on terms that the Buyer shall indemnify the Seller in full against all loss (including loss of profit) costs (including the cost of all labour and materials used) damages charges and expenses incurred by the Seller as the result of cancellation.

### 4. PRICE OF THE GOODS

- 4.1 The price of the Goods shall be the price set out in the Seller's quotation, or, in the case of an Order placed without a prior quotation from the Seller the price shall be as per the Sellers most up to date price list.
- 4.2 Where the Goods are supplied for export from the United Kingdom the Seller's published export price list shall apply. All prices quoted are valid for 90 days only or until earlier acceptance by the Buyer after which time they may be altered by the Seller without giving notice to the Buyer. All orders are subject to a minimum order charge.
- 4.3 The Seller may, by giving notice to the Buyer at any time up to 30 Business Days before delivery, increase the price of the Goods to reflect any increase in the cost of the Goods that is due to:
  - 4.3.1 any factor beyond the Seller's control (including foreign exchange fluctuations, increases in taxes and duties, and increases in the cost of labour, materials and other manufacturing costs);
  - 4.3.2 any request by the Buyer to change the delivery date(s), quantities or types of Goods ordered, or the Specification; or
  - 4.3.3 any delay caused by any instructions of the Buyer or failure of the Buyer to give the Seller adequate or accurate information or instructions.

- 4.4 Except as otherwise agreed in writing between the Buyer and Seller the price of the Goods is on an ex-works basis and is exclusive of the costs and charges of packaging, carriage freight insurance and transport of the Goods which shall be invoiced to the Buyer. The Seller will use its reasonable endeavours to include the costs of [packaging, carriage, freight, [insurance] and transport] in any quotation provided to the Buyer.
- 4.5 The price of the Goods is exclusive of amounts in respect of value added tax (VAT). The Buyer shall, on receipt of a valid VAT invoice from the Seller, pay to the Seller such additional amounts in respect of VAT as are chargeable on the supply of the Goods.

- 4.6 The cost of pallets and return of containers will be charged to the Buyer in addition to the price of the Goods but full credit will be given to the Buyer provided they are returned undamaged to the Seller before the due payment date.

### 5. TERMS OF PAYMENT

- 5.1 Subject to any special terms agreed in writing between the Buyer and the Seller the Seller shall be entitled to invoice the Buyer for the price of the goods on or at any time after delivery. If the Goods are to be collected by the Buyer or the Buyer wrongfully fails to take delivery of the goods the Seller shall be entitled to invoice the Buyer for the price at any time after the Seller has notified the Buyer that the Goods are ready for collection or the Seller has tendered delivery of the Goods.
- 5.2 The Buyer shall pay the invoice in the manner detailed on the invoice in full and cleared funds on or before the last working day of the month following the date of invoice. The Seller shall be entitled to recover the invoice amount notwithstanding that delivery may not have taken place and that the property and the Goods have not passed to the Buyer. Time of payment is of the essence.
- 5.3 If the Buyer fails to make any payment on the due date then without prejudice to any other right or remedy available to the Seller the Seller shall be entitled to:
  - 5.3.1 cancel the Contract or suspend any further deliveries to the Buyer;
  - 5.3.2 appropriate any payment made by the Buyer to such of the Goods (or the Goods supplied under any other contract between the Buyer and the Seller) as the Seller may see fit (notwithstanding any purported appropriation by the Buyer) and
  - 5.3.3 charge the Buyer interest (both before and after any judgment) on the amount unpaid at the rate of 4% per cent per annum above Bank of England base rate as varied from time to time. Such interest shall accrue on a daily basis from the due date until the date of actual payment of the overdue amount, whether before or after judgment. The Buyer shall pay the interest together with the overdue amount.
- 5.4 The Buyer shall also reimburse the Seller all costs and expenses (including legal costs) incurred in the collection of any overdue amount.
- 5.5 The Buyer shall pay all amounts due under the Contract in full without any deduction or withholding except as required by law and the Buyer shall not be entitled to assert any credit, set-off or counterclaim against the Seller in order to justify withholding payment of any such amount in whole or in part. The Seller may at any time, without limiting any other rights or remedies it may have, set off any amount owing to it by the Buyer against any amount payable by the Seller to the Buyer.

### 6. DELIVERY

- 6.1 The Buyer shall collect the Goods from the Seller's premises at Unit 19, Kingfisher Park, Collingwood Road, West Moors, Wimborne, Dorset BH21 6US or such other location as may be advised by the Seller prior to delivery (**Delivery Location**) within 5 Business Days of the Seller notifying the Buyer that the Goods are ready for collection or if some other place is agreed in writing by both the Seller and Buyer then the Seller shall deliver the Goods to that location.
- 6.2 If the Seller requires the Buyer to return any packaging materials to the Seller, that fact will be clearly stated on the delivery note. The Buyer shall make any such packaging materials available for collection at such times as the Seller shall reasonably request. [Returns of packaging materials shall be at the Seller's expense.]
- 6.3 Any dates quoted for delivery are approximate only, and the time of delivery is not of the essence. The Seller shall not be liable for any delay in delivery of the Goods that is caused by a Force Majeure Event or the Buyer's failure to provide the Seller with adequate delivery instructions or any other instructions that are relevant to the supply of the Goods. The Goods may be delivered by the Seller in advance of the quoted delivery date.
- 6.4 Where delivery of the Goods is to be made by the Seller in bulk the Seller reserves the right to deliver up to 5% more or less than the quantity ordered without any adjustment in the price and the quantity so delivered shall be deemed to be the quantity ordered.
- 6.5 The Seller may at its discretion deliver the Goods by instalments, which shall be invoiced and paid for separately. Each instalment shall constitute a separate Contract. Any delay in delivery or defect in an instalment shall not entitle the Buyer to cancel any other instalment.
- 6.6 If the Seller fails to deliver the Goods, its liability shall be limited to the costs and expenses incurred by the Buyer in obtaining replacement goods of similar description and quality in the cheapest market available, less the price of the Goods. The Seller shall have no liability for any failure to deliver the Goods to the extent that such failure is caused by a Force Majeure Event or the Buyer's failure to provide the Seller with adequate delivery instructions or any other instructions that are relevant to the supply of the Goods.
- 6.7 If the Buyer fails to take delivery or collect the Goods within five Business Days of the Seller notifying the Buyer that the Goods are ready, then, except where such failure or delay is caused by a Force Majeure Event or the Seller's failure to comply with its obligations under the Contract:
  - 6.7.1 delivery of the Goods shall be deemed to have been completed at 9.00 am on the fifth Business Day after the day on which the Seller notified the Buyer that the Goods were ready; and
  - 6.7.2 the Seller shall store the Goods until delivery takes place, and charge the Buyer for all related costs and expenses (including insurance).
- 6.8 If 10 Business Days after the day on which the Seller notified the Buyer that the Goods were ready for delivery the Buyer has not taken delivery of them, the Seller may resell or otherwise dispose of part or all of the Goods.

### 7. TITLE AND RISK

- 7.1 The risk in the Goods shall pass to the Buyer on completion of delivery.
- 7.2 Title to the Goods shall not pass to the Buyer until the Seller has received payment in full (in cash or cleared funds) for:
  - 7.2.1 the Goods; and
  - 7.2.2 any other goods or services that the Seller has supplied to the Buyer in respect of which payment has become due.
- 7.3 Until title to the Goods has passed to the Buyer, the Buyer shall:
  - 7.3.1 hold the Goods on a fiduciary basis as the Seller's bailee;
  - 7.3.2 store the Goods separately from all other goods held by the Buyer so that they remain readily identifiable as the Seller's property;
  - 7.3.3 not remove, deface or obscure any identifying mark or packaging on or relating to the Goods;
  - 7.3.4 maintain the Goods in satisfactory condition and keep them insured against all risks for their full price from the date of delivery;



SOLENOID  
FLOW CONTROL  
3 PORT DIRECTIONAL CONTROL  
4 PORT DIRECTIONAL CONTROL  
CHECK AND SHUTTLE  
PILOT OPERATED CHECK  
RELIEF  
EXCESS FLOW  
FILTERS  
PRESSURE SENSING  
PUMPS  
ACTUATORS  
TECHNICAL DATA



# Terms and Conditions

7.3.5 notify the Seller immediately if it becomes subject to any of the events listed in clause 11.2; and

7.3.6 give the Seller such information relating to the Goods as the Seller may require from time to time.

7.4 If, before title to the Goods passes to the Buyer, the Buyer becomes subject to any of the events listed in clause 11.2, or the Seller reasonably believes that any such event is about to happen and notifies the Buyer accordingly, then, provided that the Goods have not been resold, or irrevocably incorporated into another product, and without limiting any other right or remedy the Seller may have, the Seller may at any time require the Buyer to deliver up the Goods and, if the Buyer fails to do so promptly, enter any premises of the Buyer or of any third party where the Goods are stored in order to recover them.

**8. QUALITY**

8.1 The Seller warrants that for a period of 12 months from the date of first use or for a period of 24 months from date of delivery (whichever expires first) the Goods shall:

8.1.1 conform in all material respects with their description;

8.1.2 be free from material defects in design, material and workmanship; and

8.1.3 be of satisfactory quality (within the meaning of the Sale of Goods Act 1979); and

8.1.4 be fit for any purpose held out by the Seller.

8.2 Subject to clause 8.1, if the Buyer gives notice in writing to the Seller during the warranty period and within a reasonable period of discovery that some or all of the Goods do not comply with the warranty set out in clause 8.10 then the Seller shall be given a reasonable opportunity to examine such Goods and the Buyer (if asked to do so by the Seller) shall return such Goods to the Seller's place of business at the Buyer's cost, and the Seller shall, at its option, repair or replace any Goods found to be defective, or refund the price of any Goods found to be defective, in full.

8.3 The Seller shall not be liable for Goods' failure to comply with the warranty set out in clause 8.1 in any of the following events:

8.3.1 the Buyer makes any further use of such Goods after giving notice in accordance with clause 8.2;

8.3.2 the defect arises because the Buyer failed to follow the Seller's oral or written instructions as to the storage, commissioning, installation, use and maintenance of the Goods or (if there are none) good trade practice regarding the same;

8.3.3 the defect arises as a result of the Seller following any drawing, design or Specification supplied by the Buyer;

8.3.4 the Buyer alters or repairs such Goods without the written consent of the Seller;

8.3.5 the defect arises as a result of fair wear and tear, wilful damage, negligence, or abnormal storage or working conditions;

8.3.6 the Goods differ from their description as a result of changes made to ensure they comply with applicable statutory or regulatory requirements;

8.3.7 the Goods are used in an application beyond the Seller's design specification

8.4 Except as provided in this clause 8, the Seller shall have no liability to the Buyer in respect of the Goods' failure to comply with the warranty set out in clause 8.1.

8.5 Except as set out in these Conditions, all warranties, conditions and other terms implied by statute or common law are, to the fullest extent permitted by law, excluded from the Contract.

8.6 These Conditions shall apply to any repaired or replacement Goods supplied by the Seller.

**9. LIMITATION OF LIABILITY**

9.1 Nothing in these Conditions shall limit or exclude the Seller's liability for:

9.1.1 death or personal injury caused by its negligence, or the negligence of its employees, agents or subcontractors (as applicable);

9.1.2 fraud or fraudulent misrepresentation;

9.1.3 breach of the terms implied by section 12 of the Sale of Goods Act 1979;

9.1.4 defective products under the Consumer Protection Act 1987 (where applicable); or

9.1.5 any matter in respect of which it would be unlawful for the Seller to exclude or restrict liability.

9.2 Subject to clause 9.1 the Seller shall under no circumstances whatsoever be liable to the Buyer, whether in contract, tort (including negligence), breach of statutory duty, or otherwise, for any loss of profit, or any indirect or consequential loss arising under or in connection with the Contract.

**10. FORCE MAJEURE**

10.1 Neither party shall be liable for any failure or delay in performing its obligations under the Contract to the extent that such failure or delay is caused by a Force Majeure Event. A Force Majeure Event means any event beyond a party's reasonable control, which by its nature could not have been foreseen, or, if it could have been foreseen, was unavoidable, including strikes, lock-outs or other industrial disputes (whether involving its own workforce or a third party's), failure of energy sources or transport network, acts of God, war, terrorism, riot, civil commotion, interference by civil or military authorities, national or international calamity, armed conflict, malicious damage, breakdown of plant or machinery, nuclear, chemical or biological contamination, sonic boom, explosions, collapse of building structures, fires, floods, storms, earthquakes, loss at sea, epidemics or similar events, natural disasters or extreme adverse weather conditions, or default of Sellers or subcontractors.

**11. BUYER INSOLVENCY OR INCAPACITY**

11.1 If the Buyer becomes subject to any of the events listed in clause 11.2(a)-(j), or the Seller reasonably believes that the Buyer is about to become subject to any of them and notifies the Buyer accordingly, then, without limiting any other right or remedy available to the Seller, the Seller may cancel or suspend all further deliveries under the Contract or under any other contract between the Buyer and the Seller without incurring any liability to the Buyer, and all outstanding sums in respect of Goods delivered to the Buyer shall become immediately due.

11.2 For the purposes of clause 11.1 the relevant events are:

(a) the Buyer suspends, or threatens to suspend, payment of its debts, or is unable to pay its debts as they fall due or admits inability to pay its debts, or (being a company) is deemed unable to pay its debts within the meaning of section 123 of the Insolvency Act 1986, or (being an individual) is deemed either unable to pay its debts or as having no reasonable prospect of so doing, in either case, within the meaning of section 268 of the Insolvency Act 1986, or (being a partnership) has any partner to whom any of the foregoing apply;

(b) the Buyer commences negotiations with all or any class of its creditors with a view to rescheduling any of its debts, or makes a proposal for or enters into any compromise or arrangement with its creditors;

(c) (being a company) a petition is filed, a notice is given, a resolution is passed, or an order is made, for or in connection with the winding up of the Buyer, other than for the sole purpose of a scheme for a solvent amalgamation of the Buyer with one or more other companies or the solvent reconstruction of the Buyer;

(d) (being an individual) the Buyer is the subject of a bankruptcy petition or order;

(e) a creditor or encumbrance of the Buyer attaches or takes possession of, or a distress, execution, sequestration or other such process is levied or enforced on or sued against, the whole or any part of its assets and such attachment or process is not discharged within 14 days;

(f) (being a company) an application is made to court, or an order is made, for the appointment of an administrator or if a notice of intention to appoint an administrator is given or if an administrator is appointed over the Buyer;

(g) (being a company) a floating charge holder over the Buyer's assets has become entitled to appoint or has appointed an administrative receiver;

(h) a person becomes entitled to appoint a receiver over the Buyer's assets or a receiver is appointed over the Buyer's assets;

(i) the Buyer suspends, threatens to suspend, ceases or threatens to cease to carry on all or substantially the whole of its business;

(j) the Buyer's financial position deteriorates to such an extent that in the Seller's opinion the Buyer's capability to adequately fulfil its obligations under the Contract has been placed in jeopardy; and

(k) (being an individual) the Buyer dies or, by reason of illness or incapacity (whether mental or physical), is incapable of managing his or her own affairs or becomes a patient under any mental health legislation.

(l) any event occurs, or proceeding is taken, with respect to the Buyer in any jurisdiction to which it is subject that has an effect equivalent or similar to any of the events mentioned in clause 11.2(a) to clause 11.2(k) (inclusive);

11.3 Termination of the Contract, however arising, shall not affect any of the parties' rights and remedies that have accrued as at termination. Clauses which expressly or by implication survive termination of the Contract shall continue in full force and effect.

## 12. TEST OR INSPECTION OF THE GOODS

12.1 Where the Contract provides for test and inspection before dispatch and delivery by or on behalf of the Buyer at the Seller's premises the following conditions shall apply:

12.2 In the event of inspection by the Buyer and/or their servant or agent any complaint in relation to the Goods must be notified to the Seller in writing within seven days of that inspection and in the absence of such notice the Buyer shall be conclusively deemed to have accepted the Goods as being in conformity with the Contract and shall not thereafter be entitled to reject the Goods.

12.3 Examination of Goods during construction by an external authority where required shall be payable by and at the cost of the Buyer in addition to the ordinary price of the Goods.

12.4 The Seller reserves the right to charge the Buyer the cost of all test pieces which comply with specification.

## 13. ASSIGNMENT AND SUBCONTRACTING

13.1 The Seller may at any time assign, transfer, charge, subcontract or deal in any other manner with all or any of its rights or obligations under the Contract.

13.2 The Buyer may not assign, transfer, charge, subcontract or deal in any other manner with all or any of its rights or obligations under the Contract without the prior written consent of the Seller.

## 14. NOTICES

14.1 Any notice or other communication given to a party under or in connection with the Contract shall be in writing, addressed to that party at its registered office (if it is a company) or its principal place of business (in any other case) or such other address as that party may have specified to the other party in writing in accordance with this clause, and shall be delivered personally, sent by pre-paid first class post, recorded delivery, commercial courier, fax or e-mail.

14.2 A notice or other communication shall be deemed to have been received: if delivered personally, when left at the address referred to in clause 14.1; if sent by pre-paid first class post or recorded delivery, at 9.00 am on the second Business Day after posting; if delivered by commercial courier, on the date and at the time that the courier's delivery receipt is signed; or, if sent by fax or e-mail, one Business Day after transmission.

14.3 The provisions of this clause shall not apply to the service of any proceedings or other documents in any legal action.

## 15. SEVERANCE

15.1 If any court or competent authority finds that any provision of the Contract (or part of any provision) is invalid, illegal or unenforceable, that provision or part-provision shall, to the extent required, be deemed to be deleted, and the validity and enforceability of the other provisions of the Contract shall not be affected.

15.2 If any invalid, unenforceable or illegal provision of the Contract would be valid, enforceable and legal if some part of it were deleted, the provision shall apply with the minimum modification necessary to make it legal, valid and enforceable.

## 16. WAIVER

A waiver of any right or remedy under the Contract is only effective if given in writing and shall not be deemed a waiver of any subsequent breach or default. No failure or delay by a party to exercise any right or remedy provided under the Contract or by law shall constitute a waiver of that or any other right or remedy, nor shall it preclude or restrict the further exercise of that or any other right or remedy. No single or partial exercise of such right or remedy shall preclude or restrict the further exercise of that or any other right or remedy.

## 17. THIRD PARTY RIGHTS

A person who is not a party to the Contract shall not have any rights under or in connection with it.

## 18. VARIATION

Except as set out in these Conditions, any variation to the Contract, including the introduction of any additional terms and conditions, shall only be binding when agreed in writing and signed by the Buyer and the Seller.

## 19. GOVERNING LAW AND JURISDICTION

The Contract, and any dispute or claim arising out of or in connection with it or its subject matter or formation (including non-contractual disputes or claims), shall be governed by, and construed in accordance with, English law, and the parties irrevocably submit to the exclusive jurisdiction of the courts of England and Wales.



SOLENOID  
FLOW CONTROL  
3 PORT DIRECTIONAL CONTROL  
4 PORT DIRECTIONAL CONTROL  
CHECK AND SHUTTLE  
PILOT OPERATED CHECK  
RELIEF  
EXCESS FLOW  
FILTERS  
PRESSURE SENSING  
PUMPS  
ACTUATORS  
TECHNICAL DATA



## Products & Descriptions

### Solenoid Valves

We offer direct acting 2 position 3 port solenoid actuated valves for use as pilot valves and for single stage operation. A number of solenoid thrusters are available, including industrial enclosures, subsea designs and ATEX approved solenoids for use in potentially explosive hazardous areas. Manufactured mostly from stainless steel, valves are available as standard ported designs or for manifold mounting, and for use with a range of media, including air and other gases, oil, water, water glycol mixes and sea water.

### Stop & Metering Valves

Our range of stop and metering valves can be supplied to suit your installation configuration requirements, including inline, manifold mounted or cartridge types for inclusion in your own manifold. Stop valves provide a full positive shut-off function, while metering valves, which are mostly supplied with a graduated micrometer style adjustment, can be used to provide speed control or any other simple orifice function where adjustment is required. Pressure compensated flow control valves are also available, providing a constant flow rate in situations where the load or supply pressure varies.

### 3 Ported Directional Control Valves

The 3B series of 2 position 3 ported directional control valves are available for use on a wide range of media, from gases to sea water and many difficult and hazardous chemicals and fluids. Using a balanced poppet design, actuation of these valves is completely independent of the main line pressures, making switching reliable and consistent. With a vent chamber between the main ports and the pilot system, different pilot and main line fluids may be used without risk of accidental mixing or contamination. Various actuation methods are available, including hydraulic and pneumatic pilots, levers and cams.

### 4 Ported Directional Control Valves

The BiS range of 4 port directional valves includes both balanced poppet and rotary shear seal designs, commonly used to give control of double acting actuators. The '4R' series valves are lever operated 2 or 3 position rotary valves offering 90° manual actuation, in both detented and non-detented configurations, and with a range of centre conditions. They may be used in many different installations, with standard threaded porting, directly mounted on manifolds, or mounted behind panels. When manual control is not required, the '6B' range of 2 position 4 way valves offer other methods of actuation, such as hydraulic and pneumatic pilots.

### Check and Shuttle Valves

The BiS range of inline check valves is a comprehensive range comprising nominal bore sizes from 1/4" to 2". Manufactured from stainless steel, they are suited to use with a wide range of liquids and gases, with pressures up to 1379 bar (20,000 psi). High cracking pressure check valves are also available by contacting the factory. In addition, there are cartridge check valves for use in manifolds or for direct integration into other equipment. The 'SV' range of shuttle valves may be selected when it is necessary for a valve to select the higher of two pressures, a function often used when redundancy of pilot systems is required.

### Pilot Operated Check Valves

Our standard range comprises single and dual pilot operated check valves, decompression checks designed to reduce shock when a high pressure line is opened, and unloader valves. Actuation may be achieved by hydraulic or pneumatic pilot, lever or cam.

### Relief Valves

We offer a comprehensive range of safety relief and relief valves for use on a wide range of media, from low pressure valves that vent to atmosphere, to high pressure (1379 bar, 20,000 psi) piped return valves. Typically, low pressure valves offer a pop-open style characteristic, while high pressure valves offer proportional or metering style operation. BiS relief valves are CE marked to denote approval as Category IV safety accessories under the 97/23/EC Pressure Equipment Directive. Many options are available, including cartridge and manifold mounted versions, and many valves are available in exotic materials including monel, inconel, hastelloy and titanium.

### Excess Flow Valves

Our range of excess flow valves are designed to meet the exacting standards of the oil & gas and petro-chemical markets. Their primary function is to shut a line down in the event of breakage or rupture of a downstream pipe or hose, or any other application where excessive flow must be avoided.

### Filters

BiS Valves offer a wide range of filtration products, ranging from small component protection filters or strainers to full pressure main line filter units. Available with a wide range of mesh ratings, our F and EF series filters can provide vital protection for contaminant sensitive downstream components, and are particularly designed to protect against rogue pieces of debris that have passed the main line filtration or were built into the system during manufacture. Our SF and DF filters may be used as main line filters in the supply line, and offer various features such as bypasses, clogging indicators, and for the duplex style filters, on-line servicing.

### Pressure Sensing Valves

The '3SV' series-sensing valve is configured to provide a low-pressure signal switch, dependent on a separate sensed pressure of up to 414 bar (6,000 psi). The product can be used to provide a pilot pressure signal to actuate another valve when the status of a second service rises or falls beyond a pre-set pressure.

### Pumps

Our range of low flow piston pumps offer high pressures up to 827 bar (12,000 psi). Designed for use primarily with mineral oil, certain limited use with water glycols is also permitted.

## Design, Manufacturing, Testing & Quality

### Design

All BiS Valves products are supported by a team of hydraulic design engineers. As well as making continuous improvements to the current range and designing new products, the team is ready to help you find the right solution for your application.

Our design service can include making simple modifications to existing valves to make them an exact match for your requirements, through to development of a complete new valve.

Among our most popular product solutions are hydraulic manifolds where we can incorporate several valves into a single unit. This improves installation, reducing the number of expensive fittings required, makes servicing easier since pipe work does not have to be removed when a valve needs servicing, and minimises potential leakage points in the system.

We can also offer design consultancy services and we have the capability to work with you to design new products and systems, and to develop your existing designs. Contact us for details.

### Manufacturing

Manufacturing of BiS Valves products is mostly carried out in our own factory near Wimborne, Dorset, where we have extensive machining facilities devoted to close tolerance manufacture of stainless steel valve parts. In order to achieve the high levels of seat integrity required by the demanding low leakage applications that we serve in the offshore oil and gas industry, sound manufacturing and assembly techniques are essential, and are even more critical when handling more exotic materials such as monel, inconel, hastelloy and titanium.

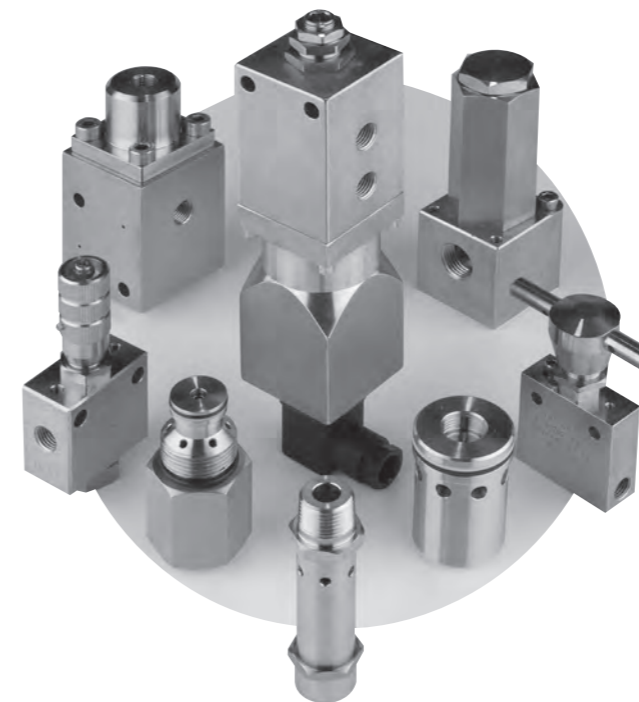

### Testing

BiS Valves has an extensive and growing list of in-house testing capability, both for production testing and for qualification work.

This includes hydraulic testing to 2,069 bar (30,000 psi), flow and pressure drop testing, pressure decay and leakage testing. Test mediums include mineral oil, water, various water glycols and nitrogen. Our capabilities, which are augmented by external testing when necessary, also include high pressure gas testing, environmental testing, hyperbaric facilities and shock and vibration testing.

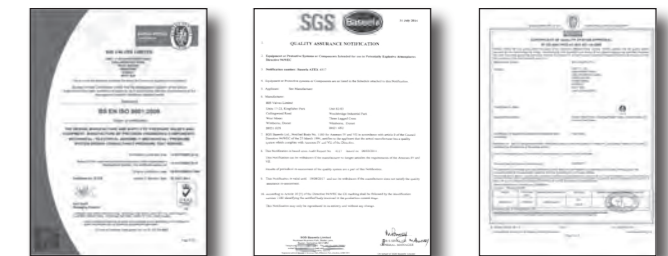

### Quality

As an ISO 9001:2008 company, our objective is to be your preferred partner and supplier, providing you with product solutions that are engineered to meet your requirements, delivered on time, with a commitment to through-life support and above all, to the quality standards demanded in today's business arena. We will continue to achieve this by focusing all personnel into sustaining the standards established by our quality system and through continuous improvement and innovation in our products, design, manufacturing and business systems.

At BiS Valves quality is of paramount importance and particular care is taken to ensure all products meet the high standards required and are tested to ultimately ensure compliance.

Our Quality Assurance Management System approvals include:-

- BS EN ISO 9001:2008 - Quality Systems
- ATEX Directive 94/9/EC Equipment for use in potentially explosive atmospheres
- Pressure Equipment Directive 97/23/EC (PED)

